

ON NONSMOOTH PERTURBATIONS OF NONDEGENERATE PLANAR CENTERS

DOUGLAS D. NOVAES

To Jaume Llibre in his 60th birthday

Abstract: We provide sufficient conditions for the existence of limit cycles of non-smooth perturbed planar centers when the discontinuity set is a union of regular curves. We introduce a mechanism which allows us to deal with such systems. The main tool used in this paper is the averaging method. Some applications are explained with careful details.

2010 Mathematics Subject Classification: 34A36, 34C29, 37G15, 37C27, 37C30.

Key words: Averaging method, algebraic variety, periodic solution, nondegenerate center, discontinuous differential system.

1. Introduction

The theory of discontinuous systems has been developing at a very fast pace in recent years and it has become certainly an important common frontier between Mathematics, Physics, Engineering and other fields of science. The study of this kind of systems is motivated by various applications. For instance, we may cite some problems in control theory [3], nonlinear oscillations [1, 20], nonsmooth mechanics [6], economics [11, 15], biology [4], and others.

On the other hand, the knowledge of the existence or not of periodic solutions is very important for understanding the dynamics of differential systems. One of the useful tools to detect such objects is the averaging theory, which is a classical and mature tool that provides techniques to study the behavior of nonlinear smooth dynamical systems. We refer to the books of Sanders and Verhulst [21] and Verhulst [22] for a general introduction about this subject.

In [7], Buică and Llibre generalized the averaging theory for studying periodic solutions of continuous differential systems mainly using the Brouwer degree. More recently in [18], Llibre, Novaes, and Teixeira

extended the averaging theory for studying periodic solutions of a class of piecewise continuous differential systems with two zones.

In what follows, we introduce the class of piecewise continuous systems with two zones.

Let D be an open subset of \mathbb{R}^n . Let $X, Y: D \rightarrow \mathbb{R}^n$ be two continuous vector fields and let $h: D \rightarrow \mathbb{R}$ be a C^1 function. The discontinuity set $h^{-1}(0)$ is denoted by M . So we define a *piecewise continuous differential system* with two zones as

$$(1) \quad x'(t) = Z(x) = \begin{cases} X(x) & \text{if } h(x) > 0, \\ Y(x) & \text{if } h(x) < 0, \end{cases}$$

which we denote concisely by $Z = (X, Y)_h$. It is worth to say that this definition can be easily extended to non-autonomous systems.

Let the sign function be defined in $R \setminus \{0\}$ as

$$\text{sign}(u) = \begin{cases} 1 & \text{if } u > 0, \\ -1 & \text{if } u < 0. \end{cases}$$

The piecewise continuous differential system (1) can be conveniently written as

$$(2) \quad x'(t) = Z(x) = Z_1(x) + \text{sign}(h(x))Z_2(x),$$

where

$$Z_1(x) = \frac{1}{2}(X(x) + Y(x)) \quad \text{and} \quad Z_2(x) = \frac{1}{2}(X(x) - Y(x)).$$

In [18], conditions for the existence of periodic solutions when the discontinuity set M is a regular manifold are exhibited. However, many applications deal with discontinuous systems having the discontinuity set as an algebraic variety, see for instance the book of Andronov, Vitt, and Khaikin [1] and the book of Barbashin [3]. In fact, some problems contained in [3] were the main source of motivation of the present work.

In few words, our main result deals with discontinuous perturbation of nondegenerate planar centers. The discontinuity set M is supposed to be a union of regular curves, which includes, particularly, the case when M is an algebraic variety. Moreover, conditions for the existence of periodic solutions of such perturbed systems are presented, via averaging theory.

We also provide two applications with careful details. The first one generalizes the problem of an *m-piecewise discontinuous Liénard polynomial differential equation of degree n* proposed by Llibre and Teixeira [19]; the second application deals with a plane divided in a mesh,

where each piece admits one of the two vector fields. For these systems, the existence of periodic solutions is studied.

The paper is organized as follows. In Section 2 the main result is stated. In Section 3 we present some useful elements of the averaging theory and Brouwer degree theory. In Section 4 we prove the results presented in Section 2, and in Section 5 applications of the results are discussed.

2. Statement of the main result

Let D be an open subset of \mathbb{R}^2 . We consider the following planar discontinuous differential system

$$(3) \quad \begin{aligned} x'(t) &= X(x, y) + \varepsilon F_1(x, y), \\ y'(t) &= Y(x, y) + \varepsilon F_2(x, y), \end{aligned}$$

with

$$F_i(x, y) = F_{i,1}(x, y) + \text{sign}(h(x, y)) F_{i,2}(x, y),$$

where $X, Y, F_{i,j} : D \rightarrow \mathbb{R}^2$ for $i, j = 1, 2$ are continuous functions being $F_{i,j}$ for $i, j = 1, 2$ locally Lipschitz, and $h : \mathbb{R}^2 \rightarrow \mathbb{R}$ is a C^1 function. Furthermore, we shall consider that the origin of the unperturbed system (3) ($\varepsilon = 0$) is a nondegenerate global center in D .

Usually, 0 is assumed to be a regular value of the function h which implies that $M = h^{-1}(0)$ is a regular manifold, see for instance Theorem 3 of this paper. Here, we assume that

(H1) The set of nonregular points in $M = h^{-1}(0)$ is bounded. In other words, for

$$N = \{(x, y) \in M : \nabla h(x, y) = (0, 0)\},$$

we can choose $\delta > 0$ such that $N \subset \overline{B_\delta(0, 0)}$. Here, $B_\delta(0, 0) \subset \mathbb{R}^2$ is the open ball with radius δ centered at $(0, 0)$.

We denote $\mathcal{M} = M \setminus \overline{B_\delta(0, 0)}$, which is an embedded submanifold in $D \subset \mathbb{R}^2$. In addition for the set \mathcal{M} we assume that

(H2) $\langle \nabla h(x, y), (-y, x) \rangle \neq 0$ for all $(x, y) \in \overline{\mathcal{M}}$.

Remark 1. Geometrically, Hypothesis (H2) is equivalent to $(-y, x) \notin T_{(x,y)}\mathcal{M}$ because $T_{(x,y)}\mathcal{M}$ is the kernel of the operation inner product by $\nabla h(x, y)$.

The idea of the proof of our main result (see Theorem A) consists in defining a convenient change of variables which drives some restrictions

of system (3) to a system whose discontinuity set is a regular manifold. To do this we define the function $\Psi_\delta: \mathbb{S}^1 \times \mathbb{R}^+ \rightarrow \mathbb{R}^2$ as

$$(4) \quad \Psi_\delta(\theta, r) = ((r + \delta) \cos(\theta), (r + \delta) \sin(\theta)),$$

where $\delta > 0$ is chosen in (H1). Clearly, this function is a diffeomorphism onto its image. Furthermore, $\overline{B_\delta(0, 0)} \cap \Psi_\delta(\mathbb{S}^1 \times \mathbb{R}^+) = \emptyset$. Now, let $\tilde{\rho} > 0$ be a real number such that $\Psi_\delta(\mathbb{S}^1 \times (0, \tilde{\rho})) \subset D$, and denote $\tilde{D} = \mathbb{S}^1 \times (0, \tilde{\rho})$.

For simplicity, given a function $H: \Psi_\delta(\tilde{D}) \rightarrow \mathbb{R}$ and $\delta > 0$ we denote $\delta^*H(\theta, r) = H \circ \Psi_\delta(\theta, r)$.

Example 1. To illustrate Hypothesis (H1) and the change of variables (4), we consider the function $h(x, y) = (x^2 - 1)(y^2 - 1)$. The set $M = h^{-1}(0)$ is represented by the bold lines in Figure 1. Observe that M is not a regular manifold since it has self-intersections at the points $N = \{(1, 1), (-1, 1), (1, -1), (-1, -1)\} \subset \overline{B_1(0, 0)}$. So, choosing $\delta = \sqrt{2}$ and proceeding with the change of variables defined above, the set $\tilde{\mathcal{M}} = (\delta^*h)^{-1}(0)$, represented by the bold lines in Figure 2, becomes a regular submanifold of \tilde{D} (we shall use this example in Application 2 of Section 5). This procedure of finding a conveniently change of variables to remove undesirable regions can be replied for other systems, even in higher dimension.

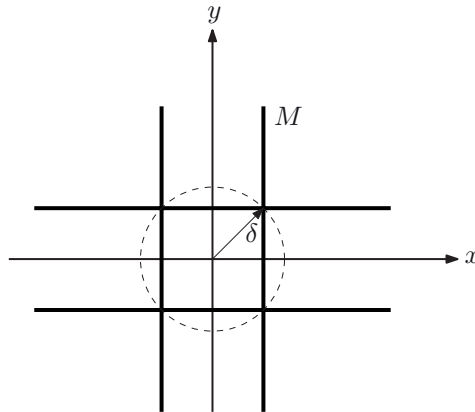

FIGURE 1. The set $M = h^{-1}(0) \subset D$ is not a regular manifold since it has self-intersections at the points $N = \{(1, 1), (-1, 1), (1, -1), (-1, -1)\} \subset \overline{B_1(0, 0)}$.

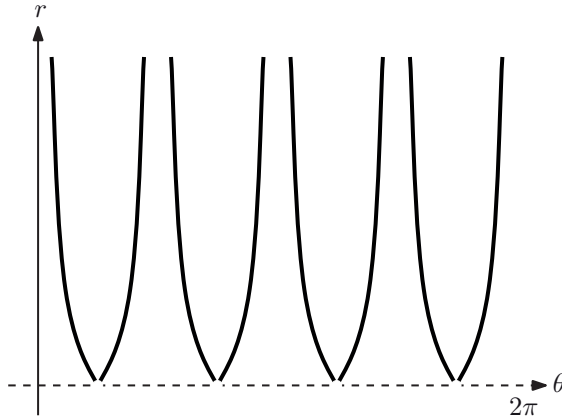

FIGURE 2. Proceeding with the change of variables $\widetilde{\mathcal{M}} = (\delta^*h)^{-1}(0)$, the set $\widetilde{\mathcal{M}}$ is now a regular submanifold of \widetilde{D} .

For the functions X and Y from (3) we assume that

(H3) For each $(\theta, r) \in \widetilde{D}$ the following relations hold:

$$S(\theta, r) = \cos(\theta)\delta^*X(\theta, r) + \sin(\theta)\delta^*Y(\theta, r) = 0, \quad \text{and}$$

$$T(\theta, r) = \cos(\theta)\delta^*Y(\theta, r) - \sin(\theta)\delta^*X(\theta, r) \neq 0.$$

The next proposition gives a class of nondegenerate planar centers for which Condition (H3) is verified, assuring then its non-emptiness.

Proposition 1. *Consider the functions*

$$X(x, y) = \sum_{m=1}^{\mu} f_m(x, y) \quad \text{and} \quad Y(x, y) = \sum_{m=1}^{\mu} g_m(x, y),$$

where

$$f_m(x, y) = \sum_{i=0}^m a_{m,i}x^{m-i}y^i \quad \text{and} \quad g_m(x, y) = \sum_{i=0}^m b_{m,i}x^{m-i}y^i;$$

and assume the following conditions are satisfied:

- (a) $a_{m,0} = b_{m,m} = 0$ and $b_{m,i} = -a_{m,i+1}$ for $i = 0, 2, \dots, m - 1$ and for $m = 1, 2, \dots, \mu$;
- (b) $b_{m,i} > 0$ if $(m, i) = (1, 0)$; $b_{m,i} \geq 0$ if $(m, i) = (2(n + j) + 1, 2j)$ with $(n, j) \in \mathbb{N}^2$ and $n + j \leq \frac{\mu-1}{2}$; and $b_{m,i} = 0$ otherwise.

Then, (H3) holds for the functions X and Y .

Remark 2. The Hypothesis (H3) implies the existence of $\rho' > 0$ such that the restriction of the unperturbed system (3) (i.e. $\varepsilon = 0$) to the ball $B_{\rho'}(0, 0)$ is conjugated to the linear center. In other words, the unperturbed system (3) is locally conjugated to the linear center at the origin. From our assumptions, it follows that $D \subset B_{\rho'}(0, 0)$.

Now, we define the *averaged function* $f: (0, \tilde{\rho} - \delta) \rightarrow \mathbb{R}$ as

$$\begin{aligned}
 (5) \quad f(r) = & (r + \delta) \int_0^{2\pi} \left(\frac{\delta^* F_{1,1}(\theta, r) \cos(\theta) + \delta^* F_{2,1}(\theta, r) \cos(\theta)}{(\delta^* Y(\theta, r) \cos(\theta) - \delta^* X(\theta, r) \sin(\theta))^2} \right. \\
 & \left. + \text{sign}(\delta^* h(\theta, r)) \frac{\delta^* F_{1,2}(\theta, r) \cos(\theta) + \delta^* F_{2,2}(\theta, r) \sin(\theta)}{(\delta^* Y(\theta, r) \cos(\theta) - \delta^* X(\theta, r) \sin(\theta))^2} \right) d\theta.
 \end{aligned}$$

The function (5) is a suitable modification via the change of variables defined in (4) for system (3), of the averaged function (12) of Theorem 2 (see Section 3). In Example 2 we can see how useful is this function. In what follows we state a hypothesis for the function f . It uses the concept of Brouwer degree d_B which is defined in Section 3.

(H4) For some $a \in (\delta, \tilde{\rho})$ with $f(a - \delta) = 0$, there exists a neighborhood $V \subset (0, \tilde{\rho} - \delta)$ of $a - \delta$ such that $f(z) \neq 0$ for all $z \in \overline{V} \setminus \{a - \delta\}$ and $d_B(f, V, 0) \neq 0$.

Remark 3. When f (defined in (5)) is a C^1 function, Hypothesis (H4) becomes:

(H4') For some $a \in (\delta, \tilde{\rho})$ with $f(a - \delta) = 0$ we have $f'(a - \delta) \neq 0$.

Our main result, which provides conditions for the existence of periodic solutions of the nonsmooth perturbed system (3), is the following.

Theorem A. *If (H1)–(H4) hold, then for $|\varepsilon| > 0$ sufficiently small there exists a periodic solution $(x(t, \varepsilon), y(t, \varepsilon))$ of system (3) such that $|(x(t, \varepsilon), y(t, \varepsilon))| \rightarrow a$ when $\varepsilon \rightarrow 0$, for every $t \in \mathbb{R}$.*

The following corollary deals with the perturbations of the linear planar center.

Corollary B. *We consider the linear planar center $(X(x, y), Y(x, y)) = (y, -x)$. Then the averaged function $f: \mathbb{R}^+ \rightarrow \mathbb{R}$ defined in (5) becomes*

$$\begin{aligned}
 (6) \quad f(r) = & - \int_0^{2\pi} (\delta^* F_{1,1}(\theta, r) \cos(\theta) + \delta^* F_{2,1}(\theta, r) \sin(\theta)) d\theta \\
 & - \int_0^{2\pi} \text{sign}(\delta^* h(\theta, r)) (\delta^* F_{1,2}(\theta, r) \cos(\theta) + \delta^* F_{2,2}(\theta, r) \sin(\theta)) d\theta.
 \end{aligned}$$

If (H1), (H2), and (H4) hold, then for $|\varepsilon| > 0$ sufficiently small there exists a periodic solution $(x(t, \varepsilon), y(t, \varepsilon))$ of system (3) such that, for every $t \in \mathbb{R}$, $|(x(t, \varepsilon), y(t, \varepsilon))| \rightarrow a$ when $\varepsilon \rightarrow 0$.

Remark 4. For $(X(x, y), Y(x, y)) = (y, -x)$, the origin of the unperturbed system (3) ($\varepsilon = 0$) is a global center in \mathbb{R}^2 , so we can choose $\tilde{\rho} > 0$ as large as we want.

Example 2. As an illustration of Theorem A and Corollary B we consider the following differential equation

$$(7) \quad \ddot{x}(t) = -x + \varepsilon (\dot{x} - \text{sign}(\dot{x}(x^2 - x_0^2))),$$

which is equivalent to the differential system

$$(8) \quad x'(t) = y \quad \text{and} \quad y'(t) = -x + \varepsilon (y - \text{sign}(y(x^2 - x_0^2))).$$

For (8) we have that $h(x, y) = y(x^2 - x_0^2)$. So

$$M = \{(x, y) \in \mathbb{R}^2 : x = \pm x_0 \text{ or } y = 0\}.$$

Such set is not a manifold at the points $P_1 = (-x_0, 0)$ and $P_2 = (x_0, 0)$. We note that, for $\delta = x_0$, both points are contained in the ball $\overline{B_\delta(0, 0)}$. Moreover $\langle \nabla h(x, y), (-y, x) \rangle = x(x^2 - x_0^2 - 2y^2) \neq 0$ for all $(x, y) \in \mathcal{M} = M \setminus \overline{B_\delta(0, 0)}$. So, (H2) is verified.

Now, taking $F_{1,1}(x, y) = F_{1,2}(x, y) = 0$, $F_{2,1}(x, y) = y$, and $F_{2,2}(x, y) = -1$, we can compute the averaged function (6) from Corollary B, since system (8) is a perturbed linear center. Thus

$$(9) \quad f(r) = - \int_0^{2\pi} (r + x_0) \sin^2(\theta) + \text{sign}(\tilde{h}(\theta, r)) \sin(\theta) d\theta,$$

where $\tilde{h}(\theta, r) = (r + x_0)(-x_0^2 + (r + x_0)^2 \cos^2(\theta)) \sin(\theta)$. By studying the signal changes of the function \tilde{h} we can compute the following expression for the function f :

$$(10) \quad f(r) = \frac{8r}{r + x_0} - \pi(r + x_0) - 4.$$

Now, from Corollary B and Remark 3 we have that for each $a > 0$ with $f(a - x_0) = 0$ such that $f'(a - x_0) \neq 0$ there exists a periodic solution $(x(t, \varepsilon), y(t, \varepsilon))$ of equation (7) such that $|(x(t, \varepsilon), y(t, \varepsilon))| \rightarrow a$ when $\varepsilon \rightarrow 0$, for every $t \in \mathbb{R}$. So

- if $x_0 = 0$, then

$$a_0 = \frac{4}{\pi}$$

is the solution of the system $f(a - x_0) = 0$;

- if $0 < x_0 < 1/(2\pi)$, then

$$a_1 = \frac{2}{\pi} - \frac{2\sqrt{1-2\pi x_0}}{\pi} \quad \text{and} \quad a_2 = \frac{2}{\pi} + \frac{\sqrt{1-2\pi x_0}}{\pi}$$

are solutions of the system $f(a - x_0) = 0$;

- if $x_0 = 1/(2\pi)$, then

$$a_3 = \frac{2}{\pi}$$

is the solution of the system $f(a - x_0) = 0$;

- finally, if $x_0 > 1/(2\pi)$, then the system $f(a - x_0) = 0$ has no solution for $a > x_0$.

3. Basic results on averaging theory and Brouwer degree theory

In Theorem A the function $d_B(f, V, 0)$ denotes the *Brouwer degree*, which is uniquely determined by the conditions of the next theorem (for a proof see [3]).

Theorem 2. *Let $P = \mathbb{R}^n = Q$ for a given positive integer n . For bounded open subsets V of P , consider continuous mappings $f: \bar{V} \rightarrow Q$, and points y_0 in Q such that y_0 does not lie in $f(\partial V)$ where ∂V denotes the boundary of V . Then to each such triple (f, V, y_0) , there corresponds an integer $d_B(f, V, y_0)$ having the following three properties:*

- (1) *If $d_B(f, V, y_0) \neq 0$, then $y_0 \in f(V)$. If f_0 is the identity map of P onto Q , then for every bounded open set V and $y_0 \in V$, we have*

$$d(f_0|_V, V, y_0) = \pm 1.$$

- (2 - Additivity) *If $f: \bar{V} \rightarrow Q$ is a continuous map with V a bounded open set in P , and V_1 and V_2 are a pair of disjoint open subsets of V such that*

$$y_0 \notin f(\bar{V} \setminus (V_1 \cup V_2)),$$

then

$$d(f_0, V, y_0) = d(f_0, V_1, y_0) + d(f_0, V_2, y_0).$$

- (3 - Invariance under homotopy) *Let V be a bounded open set in P , and consider a continuous homotopy $\{f_t : 0 \leq t \leq 1\}$ of maps of \bar{V} into Q . Let $\{y_t : 0 \leq t \leq 1\}$ be a continuous curve in Q such that $y_t \notin f_t(\partial V)$ for any $t \in [0, 1]$. Then $d_B(f_t, V, y_t)$ is constant in t on the interval $[0, 1]$.*

In [18] the methods of averaging theory for studying crossing periodic solutions were extended to a class of discontinuous differential systems. It has been established the following result:

Theorem 3. *We consider the following discontinuous differential system*

$$(11) \quad x'(t) = \varepsilon F(t, x) + \varepsilon^2 R(t, x, \varepsilon),$$

with

$$\begin{aligned} F(t, x) &= F_1(t, x) + \text{sign}(h(t, x))F_2(t, x), \\ R(t, x, \varepsilon) &= R_1(t, x, \varepsilon) + \text{sign}(h(t, x))R_2(t, x, \varepsilon), \end{aligned}$$

where $F_1, F_2: \mathbb{R} \times D \rightarrow \mathbb{R}^n$, $R_1, R_2: \mathbb{R} \times D \times (-\varepsilon_0, \varepsilon_0) \rightarrow \mathbb{R}^n$ and $h: \mathbb{R} \times D \rightarrow \mathbb{R}$ are continuous functions, T -periodic in the variable t and D is an open subset of \mathbb{R}^n . We also suppose that h is a C^1 function having 0 as a regular value. We denote $M = h^{-1}(0)$.

The averaged function $f: D \rightarrow \mathbb{R}^n$ is defined as

$$(12) \quad f(x) = \int_0^T F(t, x) dt.$$

We also assume that the following conditions hold:

- (i) F_1, F_2, R_1, R_2 are locally L -Lipschitz with respect to x ;
- (ii) $\partial h / \partial t \neq 0$, for all $p \in M$;
- (iii) for some $a \in D$ with $f(a) = 0$, there exists a neighbourhood V of a such that $f(z) \neq 0$ for all $z \in \overline{V} \setminus \{a\}$ and $d_B(f, V, 0) \neq 0$.

Then, for $|\varepsilon| > 0$ sufficiently small, there exists a T -periodic solution $x(\cdot, \varepsilon)$ of system (11) such that $x(0, \varepsilon) \rightarrow a$ when $\varepsilon \rightarrow 0$.

4. Proofs of Proposition 1, Theorem A, and Corollary B

Proof of Proposition 1: We must show that $S(\theta, r) = 0$ and $R(\theta, r) \neq 0$ for each $(\theta, r) \in \tilde{D}$. Thus we denote

$$\begin{aligned} \sigma_m(\theta, r) &= \cos(\theta)\delta^* f_m(\theta, r) + \sin(\theta)\delta^* g_m(\theta, r), \quad \text{and} \\ \nu_m(\theta, r) &= \cos(\theta)\delta^* g_m(\theta, r) - \sin(\theta)\delta^* f_m(\theta, r). \end{aligned}$$

So

$$\begin{aligned}
 S(\theta, r) &= \cos(\theta)\delta^*X(\theta, r) + \sin(\theta)\delta^*Y(\theta, r) \\
 &= \cos(\theta)\delta^*\left(\sum_{m=1}^{\mu} f_m(\theta, r)\right) + \sin(\theta)\delta^*\left(\sum_{m=1}^{\mu} g_m(\theta, r)\right) \\
 &= \sum_{m=1}^{\mu} (\cos(\theta)\delta^*f_m(\theta, r) + \sin(\theta)\delta^*g_m(\theta, r)) = \sum_{m=1}^{\mu} \sigma_m(\theta, r),
 \end{aligned}$$

for $m = 1, 2, \dots, \mu$; and

$$\begin{aligned}
 T(\theta, r) &= \cos(\theta)\delta^*Y(\theta, r) + \sin(\theta)\delta^*X(\theta, r) \\
 &= \cos(\theta)\delta^*\left(\sum_{m=1}^{\mu} g_m(\theta, r)\right) - \sin(\theta)\delta^*\left(\sum_{m=1}^{\mu} f_m(\theta, r)\right) \\
 &= \sum_{m=1}^{\mu} (\cos(\theta)\delta^*g_m(\theta, r) - \sin(\theta)\delta^*f_m(\theta, r)) = \sum_{m=1}^{\mu} \nu_m(\theta, r),
 \end{aligned}$$

for $m = 1, 2, \dots, \mu$.

Claim 1.1. *Condition (a) implies $\sigma_m(\theta, r) = 0$ for each $(\theta, r) \in \tilde{D}$.*

Indeed,

$$\begin{aligned}
 \sigma_m(\theta, r) &= \cos(\theta)\delta^*f_m(\theta, r) + \sin(\theta)\delta^*g_m(\theta, r) \\
 &= \cos(\theta) \sum_{i=0}^m a_{m,i}(r+\delta)^{m-i} \cos^{m-i}(\theta)(r+\delta)^i \sin^i(\theta) \\
 &\quad + \sin(\theta) \sum_{i=0}^m b_{m,i}(r+\delta)^{m-i} \cos^{m-i}(\theta)(r+\delta)^i \sin^i(\theta) \\
 &= (r+\delta)^m \left(\sum_{i=0}^m a_{m,i} \cos^{m-i+1}(\theta) \sin^i(\theta) + \sum_{i=0}^m b_{m,i} \cos^{m-i}(\theta) \sin^{i+1}(\theta) \right) \\
 &= (r+\delta)^m \left(\sum_{i=0}^{m-1} (a_{m,i+1} + b_{m,i}) \cos^{m-i}(\theta) \sin^{i+1}(\theta) \right) = 0.
 \end{aligned}$$

Hence $\sigma_m(\theta, r) = 0$ for each $m = 1, 2, \dots, \mu$ and for each $(\theta, r) \in \tilde{D}$. Therefore $S(\theta, r) = 0$ for each $(\theta, r) \in \tilde{D}$. So Claim 1.1 is verified.

Claim 1.2. *Condition (b) implies $\nu_1(\theta, r) > 0$, and $\nu_m(\theta, r) \geq 0$ for $m \neq 1$ and for each $(\theta, r) \in \tilde{D}$.*

Indeed

$$\begin{aligned} \nu_m(\theta, r) &= \cos(\theta)\delta^*g_m(\theta, r) - \sin(\theta)\delta^*f_m(\theta, r) \\ &= \cos(\theta)\sum_{i=0}^m b_{m,i}(r + \delta)^{m-i} \cos^{m-i}(\theta)(r + \delta)^i \sin^i(\theta) \\ &\quad - \sin(\theta)\sum_{i=0}^m a_{m,i}(r + \delta)^{m-i} \cos^{m-i}(\theta)(r + \delta)^i \sin^i(\theta) \\ &= (r + \delta)^m \left(\sum_{i=0}^{m-1} b_{m,i} \cos^{m-i+1}(\theta) \sin^i(\theta) - \sum_{i=1}^m a_{m,i} \cos^{m-i}(\theta) \sin^{i+1}(\theta) \right) \\ &= (r + \delta)^m \sum_{i=0}^{m-1} b_{m,i} (\cos^{m-i+1}(\theta) \sin^i(\theta) + \cos^{m-i-1}(\theta) \sin^{i+2}(\theta)) \\ &= (r + \delta)^m \sum_{i=0}^{m-1} b_{m,i} \cos^{m-i-1}(\theta) \sin^i(\theta). \end{aligned}$$

So for $(m, i) = (2(n + j) + 1, 2j)$, $\cos^{m-i-1}(\theta) \sin^i(\theta) = \cos^{2n}(\theta) \sin^{2j}(\theta)$, which implies that $\nu_m(\theta, r) \geq 0$ for m odd. Clearly, $\nu_m(\theta, r) = 0$ for m even. Hence $T(\theta, r) > 0$, since $\nu_1(\theta, r) = b_{1,0}(r + \delta) > 0$, for each $(\theta, r) \in \tilde{D}$. So Claim 1.2 is verified. \square

Proof of Theorem A: We consider system (3) restricted to $\Psi_\delta(\tilde{D})$, i.e.

$$(13) \quad (\dot{x}(t), \dot{y}(t)) = Z(x, y) = (X(x, y) + \varepsilon F_1(x, y), Y(x, y) + \varepsilon F_2(x, y)) \Big|_{\Psi_\delta(\tilde{D})}.$$

Since $\Psi_\delta: D \rightarrow \Psi_\delta(\tilde{D})$ is a diffeomorphism, thus the pullback $\Psi_\delta^*Z(\theta, r): \tilde{D} \rightarrow \mathbb{R}^2$ is well defined and the differential system

$$(14) \quad (\dot{\theta}(t), \dot{r}(t)) = \Psi_\delta^*Z(\theta, r)$$

is equivalent to (13). Moreover,

$$\begin{aligned}
 \dot{\theta}(t) &= \frac{\delta^*Y(\theta, r) \cos(\theta) - \delta^*X(\theta, r) \sin(\theta)}{r + \delta} \\
 (15) \quad &+ \varepsilon \frac{\delta^*F_2(\theta, r) \cos(\theta) - \delta^*F_1(\theta, r) \sin(\theta)}{r + \delta}, \\
 \dot{r}(t) &= \varepsilon (\delta^*F_1(\theta, r) \cos(\theta) + \delta^*F_2(\theta, r) \sin(\theta)),
 \end{aligned}$$

since $\delta^*X(\theta, r) \cos(\theta) + \delta^*Y(\theta, r) \sin(\theta) = 0$.

We note that for $|\varepsilon| > 0$ sufficiently small, Hypothesis (H3) implies that $\dot{\theta}(t) \neq 0$. So

$$(16) \quad \frac{\dot{r}(t)}{\dot{\theta}(t)} = (r + \delta) \frac{\delta^*F_1(\theta, r) \cos(\theta) + \delta^*F_2(\theta, r) \sin(\theta)}{\delta^*Y(\theta, r) \cos(\theta) - \delta^*X(\theta, r) \sin(\theta)} \left(\frac{\varepsilon}{1 - \varepsilon z(\theta, r)} \right),$$

where

$$z(\theta, r) = \frac{\delta^*F_1(\theta, r) \sin(\theta) - \delta^*F_2(\theta, r) \cos(\theta)}{\delta^*Y(\theta, r) \cos(\theta) - \delta^*X(\theta, r) \sin(\theta)}.$$

Now, taking θ as the new independent variable of (15), we obtain the expression of $dr(\theta)/d\theta$ by expanding $\dot{r}(t)/\dot{\theta}(t)$ in Taylor series around $\varepsilon = 0$ as

$$(17) \quad \frac{dr}{d\theta}(\theta) = \varepsilon(r + \delta) \frac{\delta^*F_1(\theta, r) \cos(\theta) + \delta^*F_2(\theta, r) \sin(\theta)}{\delta^*Y(\theta, r) \cos(\theta) - \delta^*X(\theta, r) \sin(\theta)} + \varepsilon^2 R(\theta, r, \varepsilon).$$

Moreover, given $\delta > 0$ and $\tilde{\rho} > 0$, there exists $\varepsilon(\tilde{\rho}) > 0$ sufficiently small such that $|z(\theta, r, \varepsilon)| < 1$ for all $(\theta, r) \in \mathbb{S}^1 \times (0, \tilde{\rho}]$ and $\varepsilon \in (-\varepsilon_0, \varepsilon_0)$. Therefore we may write

$$\varepsilon^2 R(\theta, r, \varepsilon) = -(r + \delta) \frac{\delta^*F_1(\theta, r) \cos(\theta) + \delta^*F_2(\theta, r) \sin(\theta)}{\delta^*F_2(\theta, r) \cos(\theta) - \delta^*F_1(\theta, r) \sin(\theta)} \sum_{n=2}^{\infty} z(\theta, r, \varepsilon)^n,$$

which gives rise to the following claim:

Claim A.1. *Taking $t = \theta$ and $x = r$ we have that the function $R(\theta, r, \varepsilon)$ of system (17) satisfies the hypotheses of the function $R(t, x, \varepsilon)$ of system (11) of Theorem 3.*

Let $R_1, R_2: \tilde{D} \times (-\varepsilon(\tilde{\rho}), \varepsilon(\tilde{\rho})) \rightarrow \mathbb{R}^2$ be some functions such that

$$(18) \quad R(\theta, r, \varepsilon) = R_1(\theta, r, \varepsilon) + \text{sign}(\delta^*h(\theta, r)) R_2(\theta, r, \varepsilon).$$

To prove Claim A.1 we must show that for some decomposition (18) the involved functions are continuous, 2π -periodic in the variable θ and locally Lipschitz with respect to r .

We note that

$$(19) \quad R(\theta, r, \varepsilon) = -(r + \delta) (\delta^*F_1 \cos(\theta) + \delta^*F_2 \sin(\theta)) \sum_{n=2}^{\infty} \varepsilon^{n-2} G_n(\theta, r),$$

where

$$G_n(\theta, r) = \frac{(\delta^*F_2 \cos(\theta) - \delta^*F_1 \sin(\theta))^{n-1}}{(\delta^*Y \cos(\theta) - \delta^*X \sin(\theta))^n}.$$

Applying the Binomial Formula, expression (19) becomes

$$\begin{aligned} R(\theta, r, \varepsilon) &= \sum_{n=2}^{\infty} \sum_{k=0}^{n-1} \varepsilon^{n-2} C_k^n(r) \cos^{n-k} \theta \sin^k \theta \frac{(\delta^*F_1)^{k+1} (\delta^*F_2)^{n-k-1}}{(\delta^*Y \cos \theta - \delta^*X \sin \theta)^n} \\ &\quad + \sum_{n=2}^{\infty} \sum_{k=0}^{n-1} \varepsilon^{n-2} C_k^n(r) \cos^{n-k-1} \theta \sin^{k+1} \theta \frac{(\delta^*F_1)^k (\delta^*F_2)^{n-k}}{(\delta^*Y \cos \theta - \delta^*X \sin \theta)^n}, \end{aligned}$$

with

$$C_k^m(r) = \frac{(-1)^{k+1}}{(r + \delta)} \binom{m-1}{k}.$$

Again, by applying the Binomial Formula to $(\delta^*F_i)^a$ with $i = 1, 2$ and $a \in \mathbb{N}$, we obtain

$$\begin{aligned} (\delta^*F_i)^a &= \underbrace{\sum_{l=0}^{\lfloor a/2 \rfloor} \binom{a}{2l} (\delta^*F_{i,1})^{a-2l} (\delta^*F_{i,2})^{2l}}_{P_i^a} \\ &\quad + \underbrace{\text{sign}(\delta^*h) \sum_{l=0}^{\lceil a/2 \rceil - 1} \binom{a}{2l+1} (\delta^*F_{i,1})^{a-2l-1} (\delta^*F_{i,2})^{2l+1}}_{Q_i^a}, \end{aligned}$$

where, as usual, $\lfloor u \rfloor$ denotes the greatest integer less than or equal to u and $\lceil u \rceil$ denotes the smallest integer greater than or equal to u .

Since

$$(\delta^*F_1)^a (\delta^*F_2)^b = P_1^a P_2^b + Q_1^a Q_2^b + \text{sign}(\delta^*h) (P_1^a Q_2^b + P_2^b Q_1^a),$$

it follows that $R(\theta, r, \varepsilon) = R_1(\theta, r, \varepsilon) + \text{sign}(\delta^*h(\theta, r)) R_2(\theta, r, \varepsilon)$, where

$$R_1(\theta, r, \varepsilon) = \sum_{n=2}^{\infty} \sum_{k=0}^{n-1} \varepsilon^{n-2} C_k^n(r) \cos^{n-k}(\theta) \sin^k(\theta) \frac{P_{k+1}^1 P_{n-k-1}^2 + Q_{k+1}^1 Q_{n-k-1}^2}{(\delta^*Y \cos \theta - \delta^*X \sin \theta)^n} \\ + \sum_{n=2}^{\infty} \sum_{k=0}^{n-1} \varepsilon^{n-2} C_k^n(r) \cos^{n-k-1}(\theta) \sin^{k+1}(\theta) \frac{P_k^1 P_{n-k}^2 + Q_k^1 Q_{n-k}^2}{(\delta^*Y \cos \theta - \delta^*X \sin \theta)^n},$$

and

$$R_2(\theta, r, \varepsilon) = \sum_{n=2}^{\infty} \sum_{k=0}^{n-1} \varepsilon^{n-2} C_k^n(r) \cos^{n-k}(\theta) \sin^k(\theta) \frac{P_{k+1}^1 Q_{n-k-1}^2 + P_{n-k-1}^2 Q_{k+1}^1}{(\delta^*Y \cos \theta - \delta^*X \sin \theta)^n} \\ + \sum_{n=2}^{\infty} \sum_{k=0}^{n-1} \varepsilon^{n-2} C_k^n(r) \cos^{n-k-1}(\theta) \sin^{k+1}(\theta) \frac{P_k^1 Q_{n-k}^2 + P_{n-k}^2 Q_k^1}{(\delta^*Y \cos \theta - \delta^*X \sin \theta)^n}.$$

Now, it is easy to see that the functions R_1 and R_2 are continuous, 2π -periodic in the variable θ and locally Lipschitz with respect to r . So Claim A.1 is verified.

Rewriting system (17) by making explicit the sign function, we obtain

$$(20) \quad \frac{dr}{d\theta}(\theta) = \varepsilon (G^1(\theta, r) + \text{sign}(\delta^*h(\theta, r)) G^2(\theta, r)) + \varepsilon^2 R(\theta, r, \varepsilon),$$

where

$$G^1(\theta, r) = (r + \delta) \frac{\delta^*F_{1,1}(\theta, r) \cos(\theta) + \delta^*F_{2,1}(\theta, r) \sin(\theta)}{\delta^*Y(\theta, r) \cos(\theta) - \delta^*X(\theta, r) \sin(\theta)},$$

and

$$G^2(\theta, r) = (r + \delta) \frac{\delta^*F_{1,2}(\theta, r) \cos(\theta) + \delta^*F_{2,2}(\theta, r) \sin(\theta)}{\delta^*Y(\theta, r) \cos(\theta) - \delta^*X(\theta, r) \sin(\theta)}.$$

The functions G^1 and G^2 are also continuous, 2π -periodic in the variable θ and locally Lipschitz with respect to r .

In order, to apply Theorem 3 to system (20) we shall check that condition (ii) of Theorem 3 is verified. For this, we prove the following claim:

Claim A.2. *If $\widetilde{\mathcal{M}} = (\delta^*h)^{-1}(0)$, then $(\partial(\delta^*h)/\partial\theta)(\theta, r) \neq 0$ for all $(\theta, r) \in \widetilde{\mathcal{M}}$.*

Observe that $\widetilde{\mathcal{M}} = \{(\theta, r) \in \widetilde{D} : \Psi_\delta(\theta, r) \in \mathcal{M}\}$ which is, from (H1), a regular manifold. We take $(\theta, r) \in \widetilde{\mathcal{M}}$, and denote $(\tilde{x}, \tilde{y}) = \Psi_\delta(\theta, r) \in$

\mathcal{M} . Hence, from (H2), we have that

$$\begin{aligned} \frac{\partial}{\partial \theta} \delta^* h(\theta, r) &= \frac{\partial}{\partial \theta} (h \circ \Psi_\delta)(\theta, r) \\ &= \langle \nabla h(\Psi_\delta(\theta, r)), (-(r + \delta) \sin(\theta), (r + \delta) \cos(\theta)) \rangle \\ &= \langle \nabla h(\tilde{x}, \tilde{y}), (-\tilde{y}, \tilde{x}) \rangle \neq 0. \end{aligned}$$

So Claim A.2 is verified.

Summarizing, by Claims A.1–A.2 it follows that conditions (i) and (ii) of Theorem 3 hold for system (20). Clearly, (H4) implies condition (iii) of Theorem 3. Hence, applying Theorem 3, we conclude that for $|\varepsilon| > 0$ sufficiently small, there exists a 2π -periodic solution $\theta \mapsto r(\theta, \varepsilon)$ of system (17) such that $r(0, \varepsilon) \rightarrow a$ when $\varepsilon \rightarrow 0$. This implies that for $|\varepsilon| > 0$ sufficiently small, there exists a periodic solution $(x(t, \varepsilon), y(t, \varepsilon))$ of system (3) such that $|(x(t, \varepsilon), y(t, \varepsilon))| \rightarrow a$ when $\varepsilon \rightarrow 0$ for every $t \in \mathbb{R}$. □

Proof of Corollary B: Corollary B is an immediate consequence of Proposition 1 and Theorem A. □

5. Applications

5.1. Application 1. In [19], Llibre and Teixeira have introduced the following *m*-piecewise discontinuous Liénard polynomial differential equation of degree *n*:

$$(21) \quad \begin{aligned} \dot{x} &= y + \operatorname{sgn}(g_m(x, y))F_n(x), \\ \dot{y} &= -x, \end{aligned}$$

where $F(x) = c_0 + c_1x + \dots + c_nx^n$. The zero set of the function $\operatorname{sgn}(g_m(x, y))$ with $m = 2, 4, 6, \dots$ is the product of $m/2$ straight lines passing through the origin of coordinates dividing the plane in sectors of angle $2\pi/m$.

Here, we shall consider a generalization of this problem.

Let \mathbb{T}^m denote the *m*-Torus. Given $\alpha = (\alpha_1, \alpha_2, \dots, \alpha_m) \in \mathbb{T}^m$, with $m = 2, 4, 6, \dots$, such that $0 \leq \alpha_1 < \alpha_2 < \dots < \alpha_m \leq 2\pi$, and $\delta > 0$ we consider a function $h_\alpha: \mathbb{R}^2 \rightarrow \mathbb{R}^2$ defined by

$$(22) \quad \delta^* h_\alpha(\theta, r) = (\theta - \alpha_1)(\theta - \alpha_2) \cdots (\theta - \alpha_m).$$

Thus the discontinuity set $M = h_\alpha^{-1}(0)$ is represented, partially, by the bold lines in Figure 3. We stress that only the behavior of the set M outside the ball $\overline{B_\delta(0, 0)}$ is considered, because the part of the discontinuity set M contained in $\overline{B_\delta(0, 0)}$ is not important for our arguments.

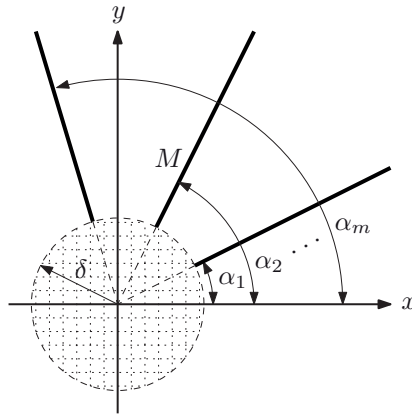

FIGURE 3. The discontinuity set $M = h_\alpha^{-1}(0) \subset \mathbb{R}^2$ outside the ball $\overline{B_\delta(0,0)}$.

A system of the form

$$(23) \quad \begin{aligned} \dot{x} &= y + \operatorname{sgn}(h_\alpha(x, y))F_n(x), \\ \dot{y} &= -x \end{aligned}$$

will be called an α -piecewise discontinuous Liénard polynomial differential system of degree n . Also, $H(m, n)$ will denote the maximum number of limit cycles that system (23) can have for any $\alpha = (\alpha_1, \alpha_2, \dots, \alpha_m) \in \mathbb{T}^m$, with $m = 2, 4, 6, \dots$, such that $0 \leq \alpha_1 < \alpha_2 < \dots < \alpha_m \leq 2\pi$. We shall use the theory developed in Section 2 to obtain estimates of $H(m, n)$.

Such kind of problem is fairly known in the literature and its origin is based in the 16th Hilbert's problem [12], see for instance: [10], [13], [14], [17], [9], and [8].

The next theorem gives a lower bound for $H(m, n)$.

Theorem 4. *The inequality $H(m, n) \geq n$ holds for $m = 2, 4, 6, \dots$ and $n \in \mathbb{N}$.*

Clearly, taking $\alpha_2 = \alpha_1 + \pi$, system (23) becomes a 2-piecewise discontinuous Liénard polynomial differential equation. In this case, Llibre and Teixeira [19] have proved that $\lfloor n/2 \rfloor$ is a lower bound for the maximum number of limit cycles of this system when $\alpha_1 = \pi/2$. In the following proposition, we assure that this result holds for every $\alpha_1 \in (0, \pi)$.

Proposition 5. *Assume that $\alpha_2 = \alpha_1 + \pi$ and $\alpha_1 \in (0, \pi)$. Then $\lfloor n/2 \rfloor$ is a lower bound for the maximum number of limit cycles of the differential system (23).*

When the symmetry $\alpha_2 = \alpha_1 + \pi$ is broken, many others limit cycles can appear, as we can see in the following proposition.

Proposition 6. *Take $\alpha = (\alpha_1, \alpha_2)$ and assume that one of the following statements hold:*

- (a) $\alpha_2 - \alpha_1 < \pi$, $\sin(\alpha_1) \cos(\alpha_1) \geq 0$ and $\sin(\alpha_2) \cos(\alpha_2) \leq 0$. Moreover one of the last two inequalities is strict;
- (b) $\alpha_2 - \alpha_1 > \pi$, $\sin(\alpha_1) \cos(\alpha_1) \leq 0$ and $\sin(\alpha_2) \cos(\alpha_2) \geq 0$. Moreover one of the last two inequalities is strict.

Then n is a lower bound for the maximum number of limit cycles of the differential system (23), that is $H(2, n) \geq n$.

Note that all points $(\alpha_1, \alpha_2) \in \mathbb{T}^2$ such that $(\alpha_1, \alpha_2) \in (0, \pi/2) \times (\pi/2, \pi)$ or $(\alpha_1, \alpha_2) \in (\pi, 3\pi/2) \times (3\pi/2, 2\pi)$ satisfy statement (a), moreover both inequalities are strict. Also, all points $(\alpha_1, \alpha_2) \in \mathbb{T}^2$ such that $(\alpha_1, \alpha_2) \in (\pi/2, \pi) \times (\alpha_1 + \pi, 2\pi)$ satisfy statement (b) and both inequalities are strict.

Clearly, Theorem 4 is valid for $m = 2$ provided that Proposition 6 holds.

To prove Propositions 5 and 6 and Theorem 4 we need a technical lemma about the number of zeros of a real polynomial.

Lemma 7. *Consider the real polynomial $p(x) = a_{i_1}x^{i_1} + a_{i_2}x^{i_2} + \dots + a_{i_r}x^{i_r}$ with $0 \leq i_1 < i_2 < \dots < i_r$ and $a_{i_j} \neq 0$ real constants for $j \in \{1, 2, \dots, r\}$. Then $p(x)$ has at most $r - 1$ positive real roots. Moreover, given $\delta > 0$ it is always possible to choose the coefficients of $p(x)$ in such a way that $p(x)$ has exactly $r - 1$ distinct real roots greater than δ .*

Proof: The proof of the lemma follows immediately by observing that the set of functions $\{x^{i_1}, x^{i_2}, \dots, x^{i_r}\}$ is an Extended Complete Chebyshev System (or just ECT-system) on the interval (δ, ∞) . For more details, see the book of Berezin and Shidkov [5], and the book of Karlin and Studden [16]. \square

We start by proving Proposition 6 since it will be used to prove Proposition 5 and Theorem 4.

Proof of Proposition 6: To prove that n is a lower bound for the maximum number of limit cycles of system (23) we shall find a polynomial function $F_n(x)$ of degree n such that the differential system (23) has n limit cycles. Thus, taking $F_n(x) = \varepsilon P_n(x)$, with $P_n(x) = a_0 + a_1x + a_2x^2 + \cdots + a_nx^n$, system (23) becomes

$$(24) \quad \begin{aligned} \dot{x} &= y + \varepsilon \operatorname{sgn}(h_\alpha(x, y))P_n(x), \\ \dot{y} &= -x. \end{aligned}$$

In order to prove the proposition we have to identify in system (23) the elements of Corollary B. Thus,

$$F_{1,1}(x, y) = F_{2,1}(x, y) = F_{2,2}(x, y) = 0, \quad \text{and} \quad F_{1,2}(x, y) = P_n(x).$$

Computing the averaged function (6), for system (24), we have

$$\begin{aligned} f(r) &= \int_0^{2\pi} \delta^* F_{1,1}(\theta, r) \cos(\theta) + \delta^* F_{2,1}(\theta, r) \sin(\theta) d\theta \\ &\quad + \int_0^{2\pi} \operatorname{sign}(\delta^* h(\theta, r)) (\delta^* F_{1,2}(\theta, r) \cos(\theta) + \delta^* F_{2,2}(\theta, r) \sin(\theta)) d\theta \\ &= \int_0^{2\pi} \cos(\theta) P_n((r + \delta) \cos(\theta)) \operatorname{sign}((\theta - \alpha_1)(\theta - \alpha_2)) d\theta \\ &= \sum_{l=0}^n a_l (r + \delta)^l \int_0^{2\pi} \cos^{l+1}(\theta) \operatorname{sign}((\theta - \alpha_1)(\theta - \alpha_2)) d\theta \\ &= \sum_{l=0}^n a_l (r + \delta)^l \left(\int_0^{\alpha_1} \cos^{l+1}(\theta) d\theta - \int_{\alpha_1}^{\alpha_2} \cos^{l+1}(\theta) d\theta + \int_{\alpha_2}^{2\pi} \cos^{l+1}(\theta) d\theta \right) \\ &= \sum_{l=0}^n a_l b_l (r + \delta)^l, \end{aligned}$$

with

$$b_l = \int_0^{\alpha_1} \cos^{l+1}(\theta) d\theta - \int_{\alpha_1}^{\alpha_2} \cos^{l+1}(\theta) d\theta + \int_{\alpha_2}^{2\pi} \cos^{l+1}(\theta) d\theta.$$

So, for $l = 0, 1$, it is easy to see that

$$\begin{aligned} b_0 &= 2 \sin(\alpha_1) - 2 \sin(\alpha_2), \\ b_1 &= \alpha_1 - \alpha_2 + \pi + \cos(\alpha_1) \sin(\alpha_1) - \cos(\alpha_2) \sin(\alpha_2). \end{aligned}$$

Now, using the identity,

$$\int \cos^{l+1}(\theta) d\theta = \frac{\cos^l(\theta) \sin(\theta)}{l+1} + \frac{l}{l+1} \int \cos^{l-1}(\theta) d\theta,$$

for $l > 0$, we conclude that, for $l > 1$,

$$\begin{aligned} b_l &= \int_0^{\alpha_1} \cos^{l+1}(\theta) d\theta - \int_{\alpha_1}^{\alpha_2} \cos^{l+1}(\theta) d\theta + \int_{\alpha_2}^{2\pi} \cos^{l+1}(\theta) d\theta \\ &= \frac{\cos^l(\alpha_1) \sin(\alpha_1)}{l+1} + \frac{l}{l+1} \int_0^{\alpha_1} \cos^{l-1}(\theta) d\theta \\ &\quad - \frac{\cos^l(\alpha_2) \sin(\alpha_2)}{l+1} + \frac{\cos^l(\alpha_1) \sin(\alpha_1)}{l} - \frac{l}{l+1} \int_{\alpha_1}^{\alpha_2} \cos^{l-1}(\theta) d\theta \\ &\quad - \frac{\cos^l(\alpha_2) \sin(\alpha_2)}{l+1} + \frac{l}{l+1} \int_{\alpha_2}^{2\pi} \cos^{l-1}(\theta) d\theta \\ &= \frac{2}{l+1} (\cos^l(\alpha_1) \sin(\alpha_1) - \cos^l(\alpha_2) \sin(\alpha_2)) \\ &\quad + \frac{l}{l+1} \left(\int_0^{\alpha_1} \cos^{l-1}(\theta) d\theta - \int_{\alpha_1}^{\alpha_2} \cos^{l-1}(\theta) d\theta + \int_{\alpha_2}^{2\pi} \cos^{l-1}(\theta) d\theta \right) \\ &= \frac{2}{l+1} (\cos^l(\alpha_1) \sin(\alpha_1) - \cos^l(\alpha_2) \sin(\alpha_2)) + \frac{l}{l+1} b_{l-2}. \end{aligned}$$

Proceeding by induction on l , we have that, for $l \geq 0$,

$$b_{2l} = \frac{2 \sin(\alpha_1)}{2l+1} \sum_{j=0}^l D_1(l, j) \cos^{2j}(\alpha_1) - \frac{2 \sin(\alpha_2)}{2l+1} \sum_{j=0}^l D_1(l, j) \cos^{2j}(\alpha_2),$$

and

$$\begin{aligned} b_{2l+1} &= \frac{\sin(\alpha_1)}{l+1} \sum_{j=0}^l D_2(l, j) \cos^{2j+1}(\alpha_1) \\ &\quad - \frac{\sin(\alpha_2)}{l+1} \sum_{j=0}^l D_2(l, j) \cos^{2j+1}(\alpha_2) + 2 \frac{(2l+1)!!}{(2l+2)!!} (\alpha_1 - \alpha_2 + \pi), \end{aligned}$$

where

$$(25) \quad D_1(p, q) = \frac{(2p)!!(2q-1)!!}{(2q)!!(2p-1)!!} \quad \text{and} \quad D_2(p, q) = \frac{(2p+1)!!(2q)!!}{(2q+1)!!(2p)!!},$$

for $p, q \in \mathbb{Z}$, where, as usual, $n!!$ denotes the Double Factorial:

$$\begin{aligned}(2n+1)!! &= 3 \cdot 5 \cdots (2n+1), \\ (2n)!! &= 2 \cdot 4 \cdot 6 \cdots (2n).\end{aligned}$$

Following Arfken and Weber [2], these are related to the regular factorial function by

$$(26) \quad (2n)!! = 2^n n! \quad \text{and} \quad (2n+1)!! = \frac{(2n+1)!}{2^n n!}.$$

It is also defined $(-1)!! = 1$ (a special case that does not follow from equation (26)).

Each of the statements, (a) and (b), implies that $b_l \neq 0$ for $l = 0, 1, 2, \dots, n$. By Lemma 7 and choosing the coefficients a_l conveniently, the polynomial $g(r) = f(r - \delta)$ has n distinct roots $r_k > \delta$ for $k = 1, 2, \dots, n$. Therefore, $f'(r_k) \neq 0$ for $k = 1, 2, \dots, n$, since the polynomial has degree n . Hence, by Corollary B, the differential equation (24) will have n limit cycles near the circles of radius r_k for $k = 1, 2, \dots, n$ for $|\varepsilon| > 0$ sufficiently small. Hence, the proposition is proved. \square

Proof of Proposition 5: Since $\alpha_2 = \alpha_1 + \pi$ and $\alpha_1 \in (0, \pi)$, we have that $\cos(\alpha_2) = -\cos(\alpha_1)$ and $\sin(\alpha_2) = -\sin(\alpha_1)$ with $\sin(\alpha) \neq 0$. Therefore

$$b_{2l} = \frac{4 \sin(\alpha_1)}{2l+1} \sum_{j=0}^l D_1(l, j) \cos^{2j}(\alpha_1) \neq 0,$$

and $b_{2l+1} = 0$ for all $l = 0, 1, \dots, \lceil n/2 \rceil - 1$.

By Lemma 7 and choosing the coefficients a_l conveniently, the polynomial $g(r) = f(r - \delta)$ has $\lfloor n/2 \rfloor$ distinct roots $r_k > \delta$ for $k = 1, 2, \dots, \lfloor n/2 \rfloor$. Clearly the other roots of that polynomial of degree $2\lfloor n/2 \rfloor$ are $-r_k$ for $l = 0, 1, 2, \dots, \lfloor n/2 \rfloor$. Therefore $f'(r_k) \neq 0$ for $k = 1, 2, \dots, \lfloor n/2 \rfloor$. Hence, by Corollary B, the differential equation (24) will have $\lfloor n/2 \rfloor$ limit cycles near the circles of radius r_k for $k = 1, 2, \dots, \lfloor n/2 \rfloor$ for $|\varepsilon| > 0$ sufficiently small and the proposition is proved. \square

Proof of Theorem 4: We take $\alpha = (\alpha_1, \alpha_2, \dots, \alpha_m) \in \mathbb{T}^m$, with $m = 2, 4, 6, \dots$, such that $0 < \alpha_1 < \alpha_2 < \dots < \alpha_m < 2\pi$. Denote $\alpha_0 = 0$ and $\alpha_{m+1} = 2\pi$. For $F_n(x) = \varepsilon P_n(x)$, with $P_n(x) = a_0 + a_1 x + a_2 x^2 + \dots + a_n x^n$. The system (23) becomes

$$(27) \quad \begin{aligned}\dot{x} &= y + \varepsilon \operatorname{sgn}(h_\alpha(x, y)) P_n(x), \\ \dot{y} &= -x.\end{aligned}$$

Computing the averaged function (6), for system (27), we have

$$f(r) = \sum_{l=0}^n a_l b_l (r + \delta)^l,$$

with

$$b_l = \sum_{i=0}^m (-1)^i \int_{\alpha_i}^{\alpha_{i+1}} \cos^{l+1}(\theta) d\theta.$$

So, for $l = 0, 1$, it is easy to see that

$$b_0 = 2 \sum_{i=1}^{m/2} (\sin(\alpha_{2i-1}) - \sin(\alpha_{2i})),$$

and

$$b_1 = \sum_{i=1}^{m/2} (\sin(\alpha_{2i-1}) \cos(\alpha_{2i-1}) - \sin(\alpha_{2i}) \cos(\alpha_{2i})) + \pi + \sum_{i=1}^{m/2} (\alpha_{2i-1} - \alpha_{2i}).$$

Proceeding as in the proof of Proposition 5, we obtain

$$b_l = \frac{2}{l+1} \sum_{i=1}^{m/2} (\sin(\alpha_{2i-1}) \cos^l(\alpha_{2i-1}) - \sin(\alpha_{2i}) \cos^l(\alpha_{2i})) + \frac{l}{l+1} b_{l-2}.$$

By induction on l , we have that

$$\begin{aligned} b_{2l} &= \frac{2}{2l+1} \sum_{i=1}^{m/2} \sum_{j=0}^l D_1(l, j) \sin(\alpha_{2i-1}) \cos^{2j}(\alpha_{2i-1}) \\ &\quad - \frac{2}{2l+1} \sum_{i=1}^{m/2} \sum_{j=0}^l D_1(l, j) \sin(\alpha_{2i}) \cos^{2j}(\alpha_{2i}), \end{aligned}$$

for $l = 0, 1, \dots, \lfloor n/2 \rfloor$, and

$$\begin{aligned} b_{2l+1} &= \frac{2}{2l+1} \sum_{i=1}^{m/2} \sum_{j=0}^l D_2(l, j) \sin(\alpha_{2i-1}) \cos^{2j+1}(\alpha_{2i-1}) \\ &\quad - \frac{2}{2l+1} \sum_{i=1}^{m/2} \sum_{j=0}^l D_2(l, j) \sin(\alpha_{2i}) \cos^{2j+1}(\alpha_{2i}) \\ &\quad + 2 \frac{(2l+1)!!}{(2l+2)!!} \left(\pi + \sum_{i=1}^{m/2} (\alpha_{2i-1} - \alpha_{2i}) \right), \end{aligned}$$

for $l = 0, 1, \dots, \lfloor n/2 \rfloor - 1$, where D_1 and D_2 are defined in (25).

Now, we take the sequence $(\beta_i)_{i \in \mathbb{N}} \subset [\pi/4, \pi/2)$ such that

$$\beta_i = \frac{\pi}{2} - \frac{\pi}{4i}.$$

For every $s > 1$, we have

$$1 > \frac{\cos(\beta_{i+1})}{\cos(\beta_i)} > \left(\frac{\cos(\beta_{i+1})}{\cos(\beta_i)} \right)^s > 0.$$

Moreover, for every $i \in \mathbb{N}$, it follows that

$$\sin\left(\frac{\pi}{2i}\right) > \sin\left(\frac{\pi}{2(i+1)}\right) > 0.$$

Therefore

$$\frac{\cos(\beta_i)}{\cos(\alpha_{i+1})} \frac{\sin(\beta_i)}{\sin(\beta_{i+1})} = \frac{\sin\left(\frac{\pi}{2i}\right)}{\sin\left(\frac{\pi}{2(i+1)}\right)} > 1.$$

Hence, for $i \in \mathbb{N}$

$$\frac{\sin(\beta_i)}{\sin(\beta_{i+1})} > \frac{\cos(\beta_{i+1})}{\cos(\beta_i)}.$$

So, for $s > 1$,

$$\frac{\sin(\beta_{2i-1})}{\sin(\beta_{2i})} > \frac{\cos(\beta_{2i})}{\cos(\alpha_{2i-1})} > \left(\frac{\cos(\beta_{2i})}{\cos(\beta_{2i-1})} \right)^s,$$

which implies that

$$\sin(\beta_{2i-1}) \cos^s(\beta_{2i-1}) > \sin(\beta_{2i}) \cos^s(\alpha_{2i}).$$

Choosing $\alpha_i = \beta_i$, for $i = 1, 2, \dots, m$, and $s = 2j$, for $j = 0, 1, \dots, l$, we have that $b_{2l} > 0$, for $l = 0, 1, \dots, \lfloor n/2 \rfloor$. Now, choosing $s = 2j + 1$, for $j = 0, 1, \dots, l$, we have

$$\sum_{i=1}^{m/2} (\alpha_{2i-1} - \alpha_{2i}) < \sum_{i=1}^{\infty} (\beta_{2i-1} - \beta_{2i}) = -\frac{\ln(2)}{4}\pi.$$

So,

$$2 \frac{(2l+1)!!}{(2l+2)!!} \left(\pi + \sum_{i=1}^{m/2} (\alpha_{2i-1} - \alpha_{2i}) \right) > 0.$$

Therefore $b_{2l+1} > 0$, for $l = 0, 1, \dots, \lfloor n/2 \rfloor - 1$.

Since $b_l \neq 0$ for $l = 0, 1, \dots, n$, by Lemma 7 and choosing the coefficients a_l conveniently the polynomial $g(r) = f(r - \delta)$ has n distinct roots $r_k > \delta$ for $k = 1, 2, \dots, n$. Therefore $f'(r_k) \neq 0$ for $k = 1, 2, \dots, n$, since the polynomial has degree n . Now, we choose $\delta > 0$ such that the circles of radius r_k , for $k = 1, 2, \dots, n$, are contained in Σ_0 . Hence, by Corollary B, for $|\varepsilon| > 0$ sufficiently small the differential equation (27) will have n limit cycles near the circles of radius r_k for $k = 1, 2, \dots, n$. Hence, Theorem 4 is proved. \square

5.2. Application 2. Consider the function $h(x, y) = (x^2 - 1)(y^2 - 1)$. The discontinuity set $M = h^{-1}(0)$ is represented by the bold lines shown in Figure 1.

Consider the equation

$$(28) \quad x''(t) = -x + \varepsilon x' \operatorname{sign}(h(x, x')).$$

Proposition 8. For $|\varepsilon| > 0$ sufficiently small there exists a periodic solution $x(t, \varepsilon)$ of system (28) such that $|(x(0, \varepsilon), x'(0, \varepsilon))| \rightarrow \sqrt{4 + 2\sqrt{2}}$ when $\varepsilon \rightarrow 0$.

Proof: First we have to identify the elements of Corollary B in system (28):

$$F_1^1(x, y) = F_2^1(x, y) = F_1^2(x, y) = 0 \quad \text{and} \quad F_2^2(x, y) = y.$$

The averaged function of system (28) is given by

$$f(a + \sqrt{2}) = (2\sqrt{2} + a) \left(\pi - 8 \operatorname{arccsc}(2\sqrt{2} + a) \right),$$

which has $a = \sqrt{4 + 2\sqrt{2}}$ as a solution. Moreover

$$\left. \frac{df}{dr}(r) \right|_{r=\sqrt{4+2\sqrt{2}}-\sqrt{2}} = 8(\sqrt{2} - 1) \neq 0.$$

Thus, (H4) holds. Clearly, (H1), (H2) and (H3) also hold in this case. Hence, the proposition follows from Corollary B. \square

In Figure 4 we can see a numeric approximation of the periodic solution given by Proposition 8.

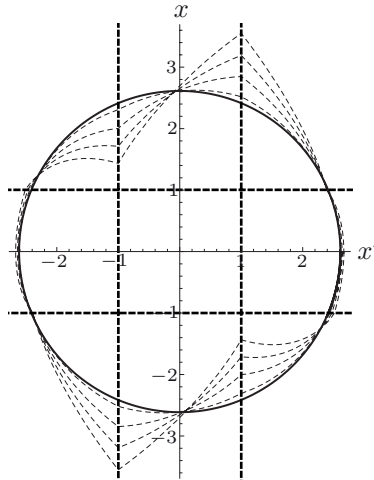

FIGURE 4. Numerical simulation of the periodic solution of (28). The dashed lines indicate the solutions for $\varepsilon = -1; -0.7; -0.4; -0.1$; the non dashed bold line indicates the solution for $\varepsilon = 0$ which is a sphere centered at the origin $(0, 0)$ with radius equal $\sqrt{4 + 2\sqrt{2}}$; and the dashed bold line indicates the discontinuity set.

Acknowledgments

The author wishes to thank the referee for comments and suggestions which helped to improve the presentation of this paper. He is also very grateful to Marco A. Teixeira for helpful discussions.

Supported by a FAPESP-BRAZIL grant 2012/10231-7.

References

- [1] A. A. ANDRONOV, A. A. VITT, AND S. E. KHAIKIN, “*Theory of oscillators*”, Translated from the Russian by F. Immirzi; translation edited and abridged by W. Fishwick Pergamon Press, Oxford-New York-Toronto, Ont., 1966.
- [2] G. B. ARFKEN AND H. J. WEBER, “*Mathematical methods for physicists*”, 5th ed., Academic Press, Orlando, FL, 2001.
- [3] E. A. BARBASHIN, “*Introduction to the theory of stability*”, Translated from the Russian by Transcripta Service, London, edited by T. Lukes Wolters-Noordhoff Publishing, Groningen, 1970.

- [4] A. D. BAZYKIN, “*Nonlinear dynamics of interacting populations*”, edited and with a foreword by A. I. Khibnik and B. Krauskopf, World Scientific Series on Nonlinear Science, Series A: Monographs and Treatises **11**, World Scientific Publishing Co., Inc., River Edge, NJ, 1998. DOI: 10.1142/9789812798725.
- [5] I. S. BEREZIN AND N. P. SHIDKOV, “*Computing methods*”, Vols. I, II, Translated by O. M. Blunn; translation edited by A. D. Booth Pergamon Press, Oxford-Edinburgh-New York-Paris-Frankfurt; Addison-Wesley Publishing Co., Inc., Reading, Mass.-London, 1965.
- [6] B. BROGLIATO, “*Nonsmooth impact mechanics*”, Models, dynamics and control, Lecture Notes in Control and Information Sciences **220**, Springer-Verlag London, Ltd., London, 1996.
- [7] A. BUICĂ AND J. LLIBRE, Averaging methods for finding periodic orbits via Brouwer degree, *Bull. Sci. Math.* **128(1)** (2004), 7–22. DOI: 10.1016/j.bulsci.2003.09.002.
- [8] P. DE MAESSCHALCK AND F. DUMORTIER, Classical Liénard equations of degree $n \geq 6$ can have $\lfloor \frac{n-1}{2} \rfloor + 2$ limit cycles, *J. Differential Equations* **250(4)** (2011), 2162–2176. DOI: 10.1016/j.jde.2010.12.003.
- [9] F. DUMORTIER, D. PANAZZOLO, AND R. ROUSSARIE, More limit cycles than expected in Liénard equations, *Proc. Amer. Math. Soc.* **135(6)** (2007), 1895–1904 (electronic). DOI: 10.1090/S0002-9939-07-08688-1.
- [10] J. ÉCALLE, “*Introduction aux fonctions analysables et preuve constructive de la conjecture de Dulac*”, Actualités Mathématiques, Hermann, Paris, 1992.
- [11] C. HENRY, Differential equations with discontinuous right-hand side for planning procedures, *J. Econom. Theory* **4(3)** (1972), 545–551.
- [12] D. HILBERT, Mathematical problems, *Bull. Amer. Math. Soc.* **8(10)** (1902), 437–479. DOI: 10.1090/S0002-9904-1902-00923-3.
- [13] YU. S. IL’YASHENKO, “*Finiteness theorems for limit cycles*”, Translated from the Russian by H. H. McFaden, Translations of Mathematical Monographs **94**, American Mathematical Society, Providence, RI, 1991.
- [14] YU. ILYASHENKO AND A. PANOV, Some upper estimates of the number of limit cycles of planar vector fields with applications to Liénard equations, Dedicated to the memory of I. G. Petrovskii on the occasion of his 100th anniversary, *Mosc. Math. J.* **1(4)** (2001), 583–599, 645.

- [15] T. ITO, A Filippov solution of a system of differential equations with discontinuous right-hand sides, *Econom. Lett.* **4**(4) (1979/80), 349–354. DOI: 10.1016/0165-1765(79)90183-6.
- [16] S. KARLIN AND W. J. STUDDEN, “*Tchebycheff systems: With applications in analysis and statistics*”, Pure and Applied Mathematics **XV**, Interscience Publishers John Wiley & Sons, New York-London-Sydney, 1966.
- [17] A. LINS, W. DE MELO, AND C. C. PUGH, On Liénard’s equation, in: “*Geometry and topology*”, (Proc. III Latin Amer. School of Math., Inst. Mat. Pura Aplicada CNPq, Rio de Janeiro, 1976), Lecture Notes in Math. **597**, Springer, Berlin, 1977, pp. 335–357.
- [18] J. LLIBRE, D. D. NOVAES, AND M. A. TEIXEIRA, On the birth of limit cycles for non-smooth dynamical systems, [arXiv:1205.4211](https://arxiv.org/abs/1205.4211).
- [19] J. LLIBRE AND M. A. TEIXEIRA, Limit cycles for m -piecewise discontinuous polynomial Liénard differential equations, *Z. Angew. Math. Phys.* (to appear).
- [20] N. MINORSKY, “*Nonlinear oscillations*”, D. Van Nostrand Co., Inc., Princeton, N.J.-Toronto-London-New York, 1962.
- [21] J. A. SANDERS AND F. VERHULST, “*Averaging methods in nonlinear dynamical systems*”, Applied Mathematical Sciences **59**, Springer-Verlag, New York, 1985.
- [22] F. VERHULST, “*Nonlinear differential equations and dynamical systems*”, Translated from the Dutch, Universitext, Springer-Verlag, Berlin, 1990. DOI: 10.1007/978-3-642-97149-5.

Departamento de Matemática
Universidade Estadual de Campinas
Caixa Postal 6065
13083-859, Campinas, SP
Brazil
E-mail address: `ddnovaes@ime.unicamp.br`