

## A THREE-MANIFOLD INVARIANT VIA THE KONTSEVICH INTEGRAL

THANG TU QUOC LE, HITOSHI MURAKAMI, JUN MURAKAMI  
 and TOMOTADA OHTSUKI

(Received September 01, 1997)

We construct an invariant for closed, oriented three-manifolds from the Kontsevich integral of framed links, and show that it includes Lescop's generalization of the Casson-Walker invariant. Combining this result and a formula for computing the Kontsevich integral in [17], we can compute the Casson-Walker invariant combinatorially in terms of  $q$ -tangles (non-associative tangles in [3]).

Our invariant is obtained from the Kontsevich integral by imposing the three-term (3T) relation, orientation independence (OI) relation, 0-vanishing relation and 1-vanishing relation to the space of chord diagrams subjected to the four-term relation. The *3T relation* is given by

$$(3T \text{ relation}) \quad \begin{array}{c} \text{---} \\ \text{---} \end{array} \left. \begin{array}{c} \text{---} \\ \text{---} \end{array} \right) + \begin{array}{c} \text{---} \\ \text{---} \end{array} \left( \begin{array}{c} \text{---} \\ \text{---} \end{array} \right) + \begin{array}{c} \text{---} \\ \text{---} \end{array} \left( \begin{array}{c} \text{---} \\ \text{---} \end{array} \right) = 0.$$

Here, dotted lines present chords and the three chord diagrams are identical except within the region where they are as above. The *OI relation* is given as follows. Let  $D$  be a chord diagram and let  $D'$  be a chord diagram obtained by changing the orientation of a string  $s$  of  $D$ . Then

$$(OI \text{ relation}) \quad D' = (-1)^{e(s)} D.$$

Here  $e(s)$  denotes the number of end points of chords on  $s$ . The *0-vanishing relation* means that a chord diagram having a string with no end points of chords is equal to 0, and the *1-vanishing relation* means that a chord diagram having a string with only one end point of chords is equal to 0.

The Kontsevich integral  $\hat{Z}_f$  of a framed link has values in the space of chord diagrams subject to the four-term relation [13, 2, 17]. Let  $\nu = \hat{Z}_f(\bigcirc)$  for the trivial knot  $\bigcirc$ , which is equal to the factor introduced in [2, 17] to normalize the effect of maximal and minimal points. For an  $\ell$ -component oriented framed link  $L$ , let

$$\check{Z}_f(L) = \hat{Z}_f(L) \# (\nu, \nu, \dots, \nu).$$

This means that we connect-sum  $\nu$  to each string of  $\hat{Z}_f(L)$ . Let  $\Lambda'(L)$  be the image of  $\check{Z}_f(L)$  by the quotient of the space of chord diagrams by 3T, OI,

0-vanishing and 1-vanishing relations, and then normalize  $\Lambda'(L)$  by using the signature of the linking matrix of  $L$ , we get an invariant of 3-manifolds  $\Lambda(M_L)$  where  $M_L$  is the 3-manifold given by the surgery on the framed link  $L$ .

We first define  $\Lambda(L)$  and prove that it is an invariant of 3-manifolds by showing the invariance of  $\Lambda(L)$  under the Kirby moves in Figure 1 [12]. Any oriented 3-manifold is obtained by the surgery on a non-oriented framed link in  $S^3$  [23], and the two oriented 3-manifolds obtained from two links are homeomorphic if and only if one of the links are obtained from the other one by a sequence of Kirby moves. In Figure 1, framings of the links are given by the blackboard framings and the part of  $L'_1$  in  $L'$  parallel to  $L_2$  is actually parallel on the blackboard.

(KI)

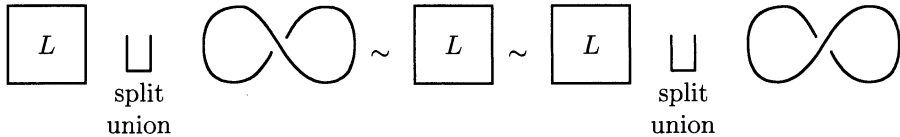

(KII)

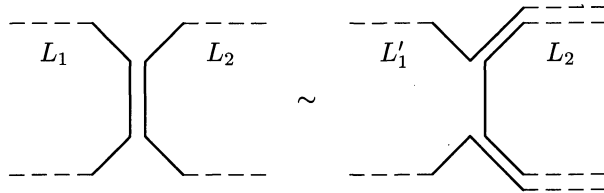

$$L = L_1 \cup L_2 \cup \dots \cup L_k \sim L' = L'_1 \cup L_2 \cup \dots \cup L_k$$

FIGURE 1. Kirby Moves

In the latter half of this paper, we study  $\Lambda(L)$  concretely, and show that it consists of the order of the first homology group and Lescop’s generalization of the Casson-Walker invariant.

After finishing this work, the theory of the universal perturbative invariant of three-manifolds is developed in [20] with this paper as a starting point.

The main results (contents of Section 1) are announced in [14].

ACKNOWLEDGMENT. Part of this work was carried out when the second, third, and fourth authors were visiting the International Institute for Advanced Study (IIAS), Kyoto in February, 1995 supported by Grant-in-Aid for Scientific Research on Priority Areas 231 “Infinite Analysis”. They thank the institute for its hospitality. Thanks are also due to T. Miwa, who arranged their visit to the IIAS. The first and the third authors thank Max-Plank-Institut für Mathematik in Bonn for giving a chance to stay together and its kind hospitality. The second author was an EPSRC Visiting Fellow in the University of Liverpool when the work

was in the final stage. The authors also thank H. Miyazawa S. Yamada, Y. Yokota, for useful discussion, and M. Okamoto for taking a note which helps them to review their discussion.

**1. Construction of a 3-manifold invariant**

We use notations in [17, 19]. Let  $C$  be a chord diagram with a distinguished string  $s$ , and let  $k$  be the number of end points of chords on  $s$ . Let  $\Delta(C)$  denote the sum of  $2^k$  diagrams obtained by adding a string parallel to  $s$  and changing each point on  $s$  as in Figure 2.

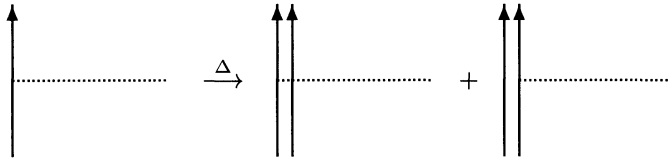

FIGURE 2. Parallel of a chord diagram

**Proposition 1.** *Let  $L$  and  $L'$  be two framed oriented links as in Figure 3, and let*

$$(1.1) \quad \check{Z}_f(L) = \sum_{X : \text{chord diagram}} \check{c}_X X.$$

*Then  $\check{Z}_f(L')$  is obtained from  $\check{Z}_f(L)$  by*

$$(1.2) \quad \check{Z}_f(L') = \sum_{X : \text{chord diagram}} \check{c}_X X',$$

*where  $\check{c}_X$  is the same as in (1.1) and  $X'$  is obtained from  $X$  as in Figure 4.*

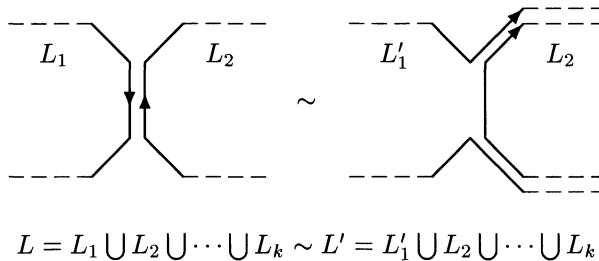

FIGURE 3. KII move for oriented framed links

This is proved in Section 2.

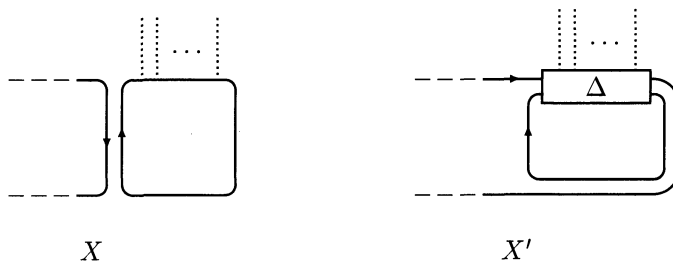

FIGURE 4. Difference of  $\check{Z}_f$  by the second Kirby move

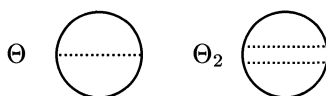

FIGURE 5.  $\Theta$  and  $\Theta_2$

Let  $\mathcal{A}^{(\ell)}$  denote the  $\mathbf{C}$ -linear space spanned by the chord diagrams on a disjoint union of  $\ell$  copies of  $S^1$  subject to the four-term relation. Let

$$\mathcal{A}_1^{(\ell)} = \mathcal{A}^{(\ell)} / (3T, \text{OI}, 0\text{-vanishing and } 1\text{-vanishing relations}).$$

Let  $\Lambda'(L)$  be the image of  $\check{Z}_f(L)$  in  $\mathcal{A}_1^{(\ell)}$  for an  $\ell$ -component framed oriented link  $L$ .

**Proposition 2.**  $\Lambda'(L)$  is invariant under the KII moves and the orientation change of each component.

This is proved in Section 3.

The structure of  $\mathcal{A}_1^{(\ell)}$  is given as follows.

**Proposition 3.**  $\mathcal{A}_1^{(\ell)}$  is a two-dimensional  $\mathbf{C}$ -vector space spanned by the two elements  $\underbrace{\Theta \sqcup \Theta \sqcup \dots \sqcup \Theta}_{\ell}$  and  $\Theta_2 \sqcup \underbrace{\Theta \sqcup \dots \sqcup \Theta}_{\ell-1}$ , where  $\Theta_2$  denotes the chord diagram on a circle with two chords as in Figure 5.

This is proved in Section 4.

We normalize  $\Lambda'(L)$  for the KI moves. For  $\ell_1, \ell_2 \geq 1$ ,  $\mathcal{A}_1^{(\ell_1)}$  and  $\mathcal{A}_1^{(\ell_2)}$  are isomorphic by identifying the corresponding basis. Let  $\mathcal{A}_1$  be a two dimensional space spanned by  $e_0$  and  $e_1$ , and we identify  $\mathcal{A}_1^{(\ell)}$  with  $\mathcal{A}_1$  by identifying  $\Theta \sqcup \Theta \sqcup \dots \sqcup \Theta$  with  $e_0$  and  $\Theta_2 \sqcup \Theta \sqcup \dots \sqcup \Theta$  with  $e_1$ . The image of  $\Lambda'(L)$  in  $\mathcal{A}_1$  is also denoted by  $\Lambda'(L)$ . We give an algebra structure to  $\mathcal{A}_1$  by

$$e_0 e_0 = e_0, \quad e_0 e_1 = e_1 e_0 = e_1, \quad e_1 e_1 = 0.$$

Then, for a split union  $L_1 \sqcup L_2$  of two framed links  $L_1$  and  $L_2$ , we have

$$(1.3) \quad \Lambda'(L_1 \sqcup L_2) = \Lambda'(L_1) \Lambda'(L_2) \in \mathcal{A}_1.$$

For trivial knots  $\infty_{\pm 1}$  with  $\pm 1$  framings, we know (from (6.3) in Section 6) that

$$(1.4) \quad \Lambda'(\infty_{+1}) = \frac{1}{2} e_0 + \frac{3}{8} e_1, \quad \Lambda'(\infty_{-1}) = -\frac{1}{2} e_0 + \frac{3}{8} e_1.$$

These elements are invertible in  $\mathcal{A}_1$  and their inverses are

$$\Lambda'(\infty_{+1})^{-1} = 2 e_0 - \frac{3}{2} e_1, \quad \Lambda'(\infty_{-1})^{-1} = -2 e_0 - \frac{3}{2} e_1.$$

So we can modify  $\Lambda'(L)$  for the KI moves as in the case of the Jones-Witten invariant. Let  $\sigma_+(L)$  (resp.  $\sigma_-(L)$ ) denote the number of positive (resp. negative) eigenvalues of the linking matrix  $B_L$  of  $L$ , and let

$$(1.5) \quad \Lambda(L) = 2^{\ell - \sigma_+(L) - \sigma_-(L)} \Lambda'(\infty_{+1})^{-\sigma_+(L)} \Lambda'(\infty_{-1})^{-\sigma_-(L)} \Lambda'(L).$$

For a framed link  $L$  and the corresponding three-manifold  $M_L$ , we have the following.

**Theorem 1.**  $\Lambda(L)$  is a topological invariant of the three-manifold  $M_L$ .

Let  $|H_1(M_L)|$  denote the order of the first homology group of  $M_L$  and  $b_1(M_L)$  the first Betti number of  $M_L$ . Let  $\tilde{\lambda}(M_L)$  be Lescop’s generalization [22] of the Casson-Walker invariant  $\lambda(M_L)$ . If  $b_1(M_L) = 0$ , it satisfies

$$\tilde{\lambda}(M_L) = |H_1(M_L)| \lambda(M_L).$$

Let  $\Lambda_0(L)$  and  $\Lambda_1(L)$  be the coefficients of  $e_0$  and  $e_1$  in  $\Lambda(L)$ , i.e.

$$(1.6) \quad \Lambda(L) = \Lambda_0(L) e_0 + \Lambda_1(L) e_1.$$

Then  $\Lambda_0(L)$  and  $\Lambda_1(L)$  satisfy the following.

**Theorem 2.**

$$(1) \quad \Lambda_0(L) = \begin{cases} |H_1(M_L)| & \text{if } b_1(M_L) = 0, \\ 0 & \text{if } b_1(M_L) > 0. \end{cases}$$

$$(2) \quad \Lambda_1(L) = -3 \tilde{\lambda}(M_L).$$

Theorem 1 is a direct consequence of our construction of  $\Lambda_1$ . To prove Theorem 2, we use the fourth author’s diagonalizing lemma given in [26, Corollary 2.5] and [25, Lemma 2.2]. According to the diagonalizing lemma, we can reduce the proof to the case of algebraically split links, for which we can prove (1). See Section 5 for detail. To prove (2), adding to the diagonalizing lemma, we use Dehn surgery formula obtained in [10] and [22] which expresses the Casson-Walker invariant in terms of linking numbers and coefficients of the Conway polynomial [22]. For

algebraically split links, this formula is rather simple and we can prove similar formula for our invariant. Comparing these formulas, we get (2). For detail, see Sections 6 and 7.

### 2. Proof of Proposition 1

We prepare several lemmas. Suppose  $X$  is a one-dimensional oriented manifold whose components are numbered. A *chord diagram with support  $X$*  is a set consisting of a finite number of unordered pairs of distinct non-boundary points on  $X$ , regarded up to orientation and component preserving homeomorphisms. We view each pair of points as a chord on  $X$  and represent it as a dashed line connecting them. Let  $\mathcal{A}(X)$  be the vector space over  $\mathbf{C}$  spanned by all chord diagrams with support  $X$ , subject to the well-known 4-term relation (see, for example, [2, 17]). The vector space  $\mathcal{A}(X)$  is graded by the number of chords, and, abusing notation, we use the same  $\mathcal{A}(X)$  for the completion of this vector space with respect to the grading. When  $X$  is  $n$  numbered lines,  $\mathcal{A}(X)$  is denoted by  $\mathcal{P}_n$ . All the  $\mathcal{P}_n$  are algebras: the product of two chord diagrams  $D_1$  and  $D_2$  is obtained by placing  $D_1$  on top of  $D_2$ . The algebra  $\mathcal{P}_1$  is commutative [2, 13].

We recall the associator  $\Phi \in \mathcal{P}_3$  in [16, 17], which is equal to  $Z_f(\begin{smallmatrix} | & \diagdown & | \\ & & \end{smallmatrix})$ , where  $\begin{smallmatrix} | & \diagdown & | \\ & & \end{smallmatrix}$  presents the trivial q-tangle on three strings with brackets  $((**))$  at the top and  $(*(**))$  at the bottom. Let  $\Phi_{321} = Z_f(\begin{smallmatrix} | & \diagup & | \\ & & \end{smallmatrix})$ , where  $\begin{smallmatrix} | & \diagup & | \\ & & \end{smallmatrix}$  presents the trivial q-tangle on three strings with brackets  $(*(**))$  at the top and  $((**))$  at the bottom. These associators correspond to the associators of quasi-Hopf algebras in [5, 6] and are also studied in [3]. For  $\mathbf{p} = (p_1, \dots, p_g)$ ,  $g(\mathbf{p}) = g$  is the length of  $\mathbf{p}$ , and  $|\mathbf{p}| = p_1 + p_2 + \dots + p_g$ . For  $\mathbf{p}$  and  $\mathbf{r}$  with the same length  $g$ ,  $\mathbf{p} \geq \mathbf{r}$  means  $p_i \geq r_i$ ,  $\mathbf{p} > \mathbf{r}$  means  $p_i > r_i$ ,  $\mathbf{p} > \mathbf{0}$  means  $p_i > 0$ , and  $\mathbf{p} \geq \mathbf{0}$  means  $p_i \geq 0$  for  $1 \leq i \leq g$ . Let  $\zeta$  be Zagier's multiple zeta function defined by

$$(2.1) \quad \zeta(s_1, \dots, s_k) = \sum_{m_1 < \dots < m_k \in \mathbf{N}} \frac{1}{m_1^{s_1} \dots m_k^{s_k}},$$

and let

$$(2.2) \quad \tau(p_1, q_1, \dots, p_n, q_n) = \zeta(\underbrace{1, \dots, 1}_{p_1-1}, q_1 + 1, \underbrace{1, \dots, 1}_{p_2-1}, q_2 + 1, \dots, q_n + 1).$$

Then

$$(2.3) \quad \Phi = 1 + \sum_{k=2}^{\infty} \frac{1}{(2\pi\sqrt{-1})^k} \sum_{g \geq 1} \sum_{\substack{\mathbf{p} > \mathbf{0}, \mathbf{q} > \mathbf{0}, \\ |\mathbf{p}| + |\mathbf{q}| = k, \\ g(\mathbf{p}) = g(\mathbf{q}) = g}} (-1)^{|\mathbf{q}|} \tau(p_1, q_1, \dots, p_g, q_g) \times \\ \sum_{\substack{g(\mathbf{r}) = g(\mathbf{s}) = g, \\ 0 \leq \mathbf{r} \leq \mathbf{p}, 0 \leq \mathbf{s} \leq \mathbf{q}}} (-1)^{|\mathbf{r}|} \left( \prod_{i=1}^g \binom{p_i}{r_i} \binom{q_i}{s_i} \right) B^{|\mathbf{s}|} A^{p_1 - r_1} B^{q_1 - s_1} \dots A^{p_g - r_g} B^{q_g - s_g} A^{|\mathbf{r}|},$$

where  $A$  (resp.  $B$ ) denotes the chord connecting the first and second (resp. the second and third) strings. Another associator  $\Phi_{321}$  is obtained from  $\Phi$  by substituting  $B$  to  $A$  and  $A$  to  $B$ .

Let

$$\boxed{\Delta} \cdots = \varepsilon_1 \left| \cdots \right| + \varepsilon_2 \left| \cdots \right|,$$

where  $\varepsilon_i = 1$  (resp.  $-1$ ) if the  $i$ -th string is oriented downward (resp. upward).

**Lemma 1.** *For any  $A \in \mathcal{P}_2$ , we have*

$$(2.4) \quad \begin{array}{|c|} \hline A \\ \hline \Delta \\ \hline \end{array} \cdots = \begin{array}{|c|} \hline \Delta \\ \hline A \\ \hline \end{array} \cdots$$

Proof. This is a special case of Lemma 2.1 in [19]. □

Let  $\Delta_3$  be a mapping from  $\mathcal{P}_3$  to  $\mathcal{P}_4$  applying  $\Delta$  to the third (right most) string of  $\mathcal{P}_3$ . Let

$$E = \overleftarrow{\downarrow} \overrightarrow{\downarrow} \downarrow, \quad F = \overleftarrow{\uparrow} \overrightarrow{\uparrow} \uparrow, \quad \alpha = \downarrow \downarrow \downarrow \downarrow, \quad \alpha' = \downarrow \downarrow \downarrow \downarrow, \\ \beta = \downarrow \downarrow \boxed{\Delta}, \quad \beta' = \downarrow \downarrow \boxed{\Delta}, \quad \beta'' = \downarrow \downarrow \boxed{\Delta}.$$

**Lemma 2.**  $E \Delta_3(\Phi) = E, \quad \Delta_3(\Phi_{321}) F = F.$

Proof. Note that

$$E \alpha = E \alpha', \quad E \beta = E \beta', \quad \alpha F = \alpha' F, \quad \beta F = \beta'' F.$$

Let  $X$  be an element of  $\mathcal{P}_3$ . By applying Lemma 1 with  $A = \alpha'$  or  $A = \beta'$  to each end point on the third string of  $X$ , we get

$$(2.5a) \quad E \alpha \Delta_3(X) = E \Delta_3(X) \alpha', \quad E \beta \Delta_3(X) = E \Delta_3(X) \beta'.$$

Similarly, we get

$$(2.5b) \quad \Delta_3(X) \alpha F = \alpha' \Delta_3(X) F, \quad \Delta_3(X) \beta F = \beta' \Delta_3(X) F.$$

Since

$$\begin{array}{|c|} \hline \Delta \\ \hline \end{array} \begin{array}{c} \uparrow \\ \downarrow \end{array} = \begin{array}{|c|} \hline \Delta \\ \hline \end{array} \begin{array}{c} \uparrow \uparrow \\ \downarrow \downarrow \end{array} = \left| \begin{array}{|c|} \hline \circ \\ \hline \end{array} \right| + \left| \begin{array}{|c|} \hline \dots \\ \hline \end{array} \right|,$$

we have

$$(2.6) \quad \alpha' \beta' = \beta' \alpha' = \alpha' \beta'' = \beta'' \alpha'.$$

We use the above expression for  $\Phi$  and  $\Phi_{321}$ . In  $\Delta_3(\Phi)$  and  $\Delta_3(\Phi_{321})$ ,  $\Delta_3(A) = \alpha$  and  $\Delta_3(B) = -\beta$ . By (2.4), (2.5) and (2.6), we have

$$E \beta^{|\mathbf{s}|} \alpha^{p_1-r_1} \beta^{q_1-s_1} \dots \alpha^{p_g-r_g} \beta^{q_g-s_g} \alpha^{|\mathbf{r}|} = E \alpha^{|\mathbf{p}|} \beta^{|\mathbf{q}|},$$

$$\alpha^{|\mathbf{s}|} \beta^{p_1-r_1} \alpha^{q_1-s_1} \dots \beta^{p_g-r_g} \alpha^{q_g-s_g} \beta^{|\mathbf{r}|} F = \alpha^{|\mathbf{q}|} \beta^{|\mathbf{p}|} F.$$

Hence

$$(2.7a) \quad E \Delta_3(\Phi) = E + \sum_{k=2}^{\infty} \frac{1}{(2\pi\sqrt{-1})^k} \sum_{g \geq 1} \sum_{\substack{\mathbf{p} > \mathbf{0}, \mathbf{q} > \mathbf{0}, \\ |\mathbf{p}|+|\mathbf{q}|=k, \\ g(\mathbf{p})=g(\mathbf{q})=g}} \tau(p_1, q_1, \dots, p_g, q_g) \times$$

$$\sum_{\substack{g(\mathbf{r})=g(\mathbf{s})=g, \\ 0 \leq \mathbf{r} \leq \mathbf{p}, 0 \leq \mathbf{s} \leq \mathbf{q}}} (-1)^{|\mathbf{q}|} (-1)^{|\mathbf{r}|} \left( \prod_{i=1}^g \binom{p_i}{r_i} \binom{q_i}{s_i} \right) E \alpha^{|\mathbf{p}|} \beta^{|\mathbf{q}|},$$

$$(2.7b) \quad \Delta_3(\Phi) F = F + \sum_{k=2}^{\infty} \frac{1}{(2\pi\sqrt{-1})^k} \sum_{g \geq 1} \sum_{\substack{\mathbf{p} > \mathbf{0}, \mathbf{q} > \mathbf{0}, \\ |\mathbf{p}|+|\mathbf{q}|=k, \\ g(\mathbf{p})=g(\mathbf{q})=g}} \tau(p_1, q_1, \dots, p_g, q_g) \times$$

$$\sum_{\substack{g(\mathbf{r})=g(\mathbf{s})=g, \\ 0 \leq \mathbf{r} \leq \mathbf{p}, 0 \leq \mathbf{s} \leq \mathbf{q}}} (-1)^{|\mathbf{p}|} (-1)^{|\mathbf{r}|} \left( \prod_{i=1}^g \binom{p_i}{r_i} \binom{q_i}{s_i} \right) \alpha^{|\mathbf{q}|} \beta^{|\mathbf{p}|} F.$$

However, we know that

$$\sum_{s_i=0}^{q_i} (-1)^{s_i} \binom{q_i}{s_i} = 0 \quad \text{if } q_i > 0, \quad \sum_{r_i=0}^{p_i} (-1)^{r_i} \binom{p_i}{r_i} = 0 \quad \text{if } p_i > 0.$$

Therefore, all the terms except the first one of the right hand sides of (2.7a) and (2.7b) vanish. Hence we get  $E \Delta_3(\Phi) = E$  and  $\Delta_3(\Phi_{321}) F = F$ . □

Let  $\nu$  be an element in  $\mathcal{P}_2$  such that  $\nu^{-1} = Z_f(\bigcap \cup)$ . By the remark at the end of Section 5 in [19], we have

$$Z_f\left(\begin{array}{|c|} \hline \Delta(\bigcap) \\ \hline \end{array}\right) = \begin{array}{|c|} \hline \begin{array}{c} \uparrow \uparrow \\ \downarrow \downarrow \end{array} \\ \hline \end{array} \begin{array}{c} \uparrow \uparrow \\ \downarrow \downarrow \end{array}, \quad Z_f\left(\begin{array}{|c|} \hline \Delta(\bigcup) \\ \hline \end{array}\right) = \begin{array}{|c|} \hline \begin{array}{c} \uparrow \uparrow \\ \downarrow \downarrow \end{array} \\ \hline \end{array} \begin{array}{c} \uparrow \uparrow \\ \downarrow \downarrow \end{array}$$



for some  $a$  and  $b$  in  $\mathcal{P}_2$  such that

$$(2.8) \quad ab = \Delta(\nu) (\nu^{-1} \otimes \nu^{-1}).$$

With these  $a$  and  $b$ , we have the following.

**Lemma 3.**  $Z_f(\text{diagram}) = \text{diagram with } \nu^{-1/2} \text{ and } a$ ,  $Z_f(\text{diagram}) = \text{diagram with } b \text{ and } \nu^{-1/2}$ .

Proof. By (2.7a) and (2.7b), we have

$$(2.9) \quad Z_f(\text{diagram}) = \text{diagram with } a, \quad Z_f(\text{diagram}) = \text{diagram with } b.$$

As q-tangles,

$$\text{diagram} = \text{diagram}, \quad \text{diagram} = \text{diagram},$$

where the brackets are given as  $(*(**))$ . On the other hand,  $\hat{Z}_f$  is obtained from  $Z_f$  by adding  $\nu^{1/2}$  at each maximal and minimal point. So, by multiplying  $\nu^{-1/2}$  at the outer strings of (2.9), we get Lemma 3. □

Proof of Proposition 1. Let

$$(2.10) \quad \hat{Z}_f(L) = \sum_{X : \text{chord diagram}} \hat{c}_X X.$$

Then, from Lemma 3,  $\hat{Z}_f(L')$  is given by

$$(2.11) \quad \hat{Z}_f(L') = \sum_{X : \text{chord diagram}} \hat{c}_X X',$$

where  $\hat{c}_X$  is given in (2.10) and  $X'$  is obtained from  $X$  as in Figure 6. Hence,  $\hat{Z}_f(L)$

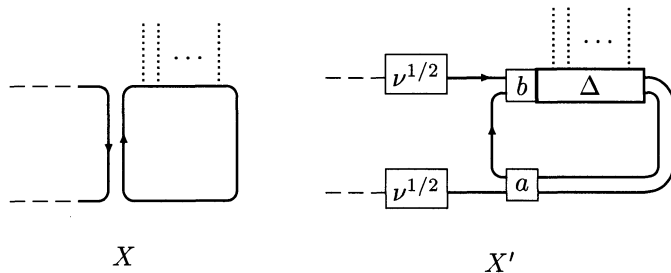

FIGURE 6. Difference of  $\hat{Z}_f$  by the second Kirby move

is given by

$$(2.12) \quad \check{Z}_f(L) = \sum_{X : \text{chord diagram}} \hat{c}_X X\#(\nu, \dots, \nu).$$

and  $\check{Z}_f(L')$  is given

$$(2.13) \quad \check{Z}_f(L') = \sum_{X : \text{chord diagram}} \hat{c}_X X'\#(\nu, \dots, \nu).$$

The difference of  $X\#(\nu, \dots, \nu)$  and  $X'\#(\nu, \dots, \nu)$  are given as in Figure 7. Ap-

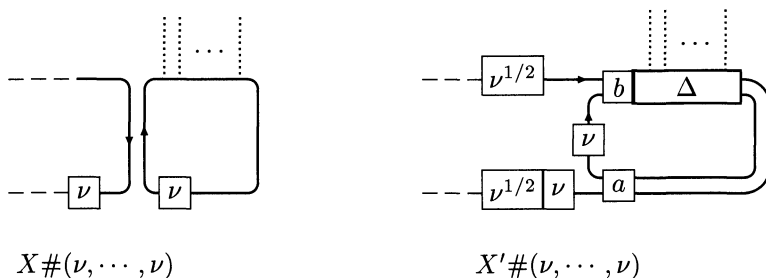
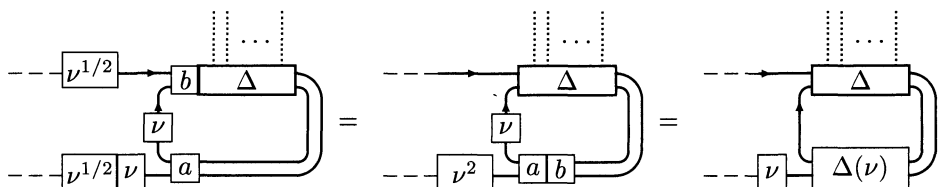

FIGURE 7. Difference of  $\check{Z}_f$  by the second Kirby move

plying Lemma 1 and (2.8) to  $X'\#(\nu, \dots, \nu)$  in Figure 7, we have



Comparing the above last term and  $X\#(\nu, \dots, \nu)$  in Figure 7, we get Proposition 1. □

### 3. Proof of Proposition 2

In this and the next sections, we extend the notion of chord diagrams by introducing trivalent vertices of dashed lines (chords) satisfying the following STU relation as in [2].

(STU relation)

$$\begin{array}{c} \diagup \\ \bullet \\ \diagdown \end{array} = \begin{array}{c} \vdots \\ \vdots \\ \vdots \end{array} - \begin{array}{c} \diagdown \\ \diagup \end{array}.$$

From this definition, the order of the edges around a trivalent vertex has meaning and we have

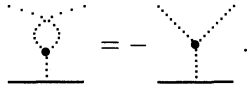
(anti-symmetry relation) 

According to the four-term relations, an element with a trivalent vertex of chords is well-defined in the space spanned by the chord diagrams subjected to the four-term relations. From the STU relation, we have the following relation, which is called the *IHX relation* in [2].

(IHX relation) 

Moreover, from STU and 3T relations, we get following two relations.

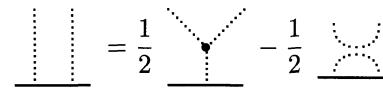
(two legs reduction) 

(three legs reduction) 

Proof of Proposition 2. According to the OI relation and the construction of the Kontsevich integral,  $\Lambda'(L)$  does not depend on the orientation of components of the link  $L$ . Hence  $\Lambda'$  is an invariant of non-oriented framed links.

Next, we show that  $\Lambda'$  is invariant by the KII move of non-oriented framed links. Since  $\Lambda'$  does not depend on the orientation, we may give orientations to the links  $L$  and  $L'$  in Figure 1 as in Figure 3. So, we prove that

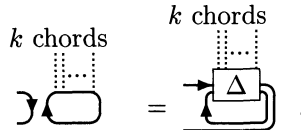

For  $k = 0, 1$ , this formula is satisfied by the 0 and 1 vanishing formulas. For  $k = 2$ , the right hand side of the formula is a sum of four diagrams. However, three of these four diagrams vanish by the 0 and 1 vanishing formulas, and the remaining diagram is the same as the diagram of the left hand side of the formula. Therefore, the formula is true for  $k = 2$  case. The  $k > 2$  cases are reduced to the above cases by using the two and three legs reductions. So the above formula is true for all  $k$ . □



and we call it the *degree of D*. All defining relations of  $\mathcal{A}_1^\ell$  are homogeneous with respect to this degree. Lemma 2 shows that the degree 0 and 1 parts of  $\mathcal{A}_1^\ell$  are both at most 1-dimensional and other parts are all 0-dimensional. Therefore, it is enough to show that the elements  $\sqcup^\ell \Theta$  and  $\Theta_2 \sqcup \left( \sqcup^\ell \Theta \right)$  do not vanish. To do this, we list up all the non-zero chord diagrams of degree 0 and 1 in  $\mathcal{A}_1^\ell$  and show that they are reduced uniquely to scalar multiples of  $\sqcup^\ell \Theta$  and  $\Theta_2 \sqcup \left( \sqcup^{\ell-1} \Theta \right)$  by the IHX, 3T, orientation independence relations and 0 vanishing formula. We write down exactly all such non-zero diagrams as scalar multiples of  $\sqcup^\ell \Theta$  and  $\Theta_2 \sqcup \left( \sqcup^{\ell-1} \Theta \right)$ , and check that all the relations are compatible with these elements.

Let  $D$  be a non-zero diagram in  $\mathcal{A}_1^\ell$  of degree 0 without vertices of chords. Then, because of the 0 and 1 vanishing formulas, each string (real line) of  $D$  has just two end points of chords. Hence  $D$  is a disjoint union of chord diagrams with several components connected by chords as a chain as in Figure 8. For these diagrams, we have

$$(4.2) \quad D^{(k)} = 1/(-2)^{k-1} \left( \sqcup^k \Theta \right).$$

Hence,

$$D = (-2)^{-(\ell-j)} \left( \sqcup^\ell \Theta \right),$$

where  $j$  is the number of connected components of  $D$ .

Let  $D$  be a non-zero diagram in  $\mathcal{A}_1^\ell$  of degree 1 without vertices of chords. Then the total number of end points of chords is equal to  $\ell + 2$  and the number of end points of chords on each string is equal to 2, 3 or 4. Hence,  $D$  is connected, or a disjoint union of one degree 1 component and other degree 0 components. Non-zero connected diagrams of degree 1 are  $D_{\pm}^{(k_1, k_2)}$ ,  $D_x^{(k_1, k_2)}$  and  $D_{\pm 1}^{(k_1, k_2, k_3)}$  in Figure 8. For these diagrams, we have

$$(4.3) \quad \begin{aligned} D_{\pm}^{(k_1, k_2)} &= 1/(-2)^{k_1+k_2} \Theta_2 \sqcup \left( \sqcup^{k_1+k_2} \Theta \right), \\ D_x^{(k_1, k_2)} &= 1/(-2)^{k_1+k_2-1} \Theta_2 \sqcup \left( \sqcup^{k_1+k_2} \Theta \right), \\ D_{\pm 1}^{(k_1, k_2, k_3)} &= \pm 3 (-2)^{-(k_1+k_2+k_3+2)} \Theta_2 \sqcup \left( \sqcup^{k_1+k_2+k_3+1} \Theta \right). \end{aligned}$$

Therefore, combining (4.2) and (4.3), we get expressions for all the non-vanishing diagrams.

Now we can check all the relation for the above non-vanishing elements. Computation is rather elementally and we omit the detail. □

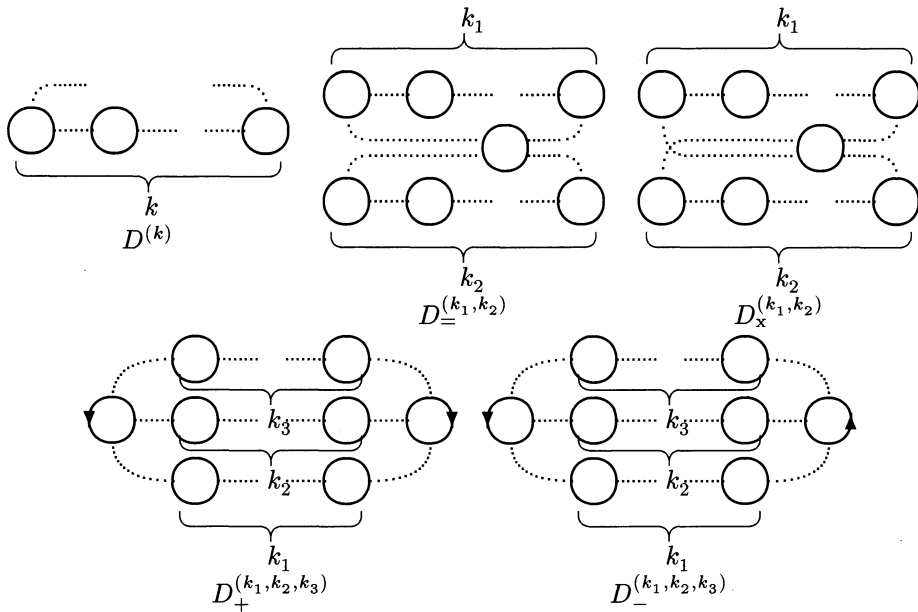

FIGURE 8. Non-vanishing diagrams

### 5. Order of the first homology group

In this section, we prove the first part of Theorem 2. We first recall the fourth author’s diagonalizing Lemma, by which we can reduce our work to simple cases. For a framed link  $L$ , let  $B_L$  denote the linking matrix of  $L$ . A framed link  $L$  is called an *algebraically split link* if  $B_L$  is a diagonal matrix.

**Lemma 6** (diagonalizing Lemma, [26, Corollary 2.5] and [25, Lemma 2.2]). *Let  $L$  be a framed link. There is an algebraically split link  $L'$  with a non-degenerate linking matrix such that  $L \sqcup L'$  is equivalent to an algebraically split link by the Kirby moves.*

Proof of Theorem 2 (1). Since  $L_0$  is additive for disjoint union of links, it will be enough to prove for algebraically split links. Let  $L$  be an algebraically split framed link. To prove (1), we compute the integral for  $L$  corresponding to the configuration of disjoint union of  $D^{(k)}$ . We give a coordinate in  $\mathbf{R}^3$  by  $(z, t) \in \mathbf{C} \times \mathbf{R} \cong \mathbf{R}^3$ , and call the  $t$ -coordinate level. Let  $L$  be an  $\ell$ -component Morse link in  $\mathbf{C} \times \mathbf{R}$  such that  $L$  is in the plane  $\mathbf{R} \times \mathbf{R}$  except a small neighborhood of the crossing points of  $L$ . Then  $L$  has a framing given by the normal vectors orthogonal to the plane  $\mathbf{R} \times \mathbf{R}$ , and we regard  $L$  as a framed link with this framing. Note that every framed link can be given by this way.

A set of  $k$  chords (dashed line segments) with end points on  $L$ , parallel to  $\mathbf{C} \times \{0\}$  on different levels each other is called a *horizontal configuration with  $k$  chords*. Two horizontal configurations  $P_1$  and  $P_2$  are considered as the same one if we can get  $P_2$  from  $P_1$  by sliding the chords of  $P_1$  keeping them parallel to the plane  $\mathbf{C} \times \{0\}$  and keeping their order with respect to the level. Then the Kontsevich integral  $Z_f(L)$  in [17] of  $L$  is written as follows.

$$(5.1) \quad Z_f(L) = \sum_{k=0}^{\infty} \sum_{\substack{P : \\ \text{horizontal configuration} \\ \text{with } k \text{ chords}}} c_P(L) D_P,$$

where  $D_P$  denote the chord diagram describing the configuration of the end points of chords of  $P$ , and the coefficient  $c_P$  is given by the modified iterated integral corresponding to  $P$  as in [17]. Let

$$(5.2) \quad \Lambda'(L) = \Lambda'_0(L) e_0 + \Lambda'_1(L) e_1.$$

Then  $\Lambda'_0(L)$  is defined from  $\check{Z}_f(L)$ , which is given by adding several  $\nu$ 's to  $Z_f(L)$ . Since  $\Lambda'_0(L)$  corresponds to the degree 0 part of  $\check{Z}_f(L)$ , and, by the argument for the degree 0 part in the previous section, only chord diagrams with just two end points of chords on each component contribute to  $\Lambda'_0(L)$ . Since, the non-trivial terms of  $\nu$  have more than three end points,  $\nu$  does not contribute to  $\Lambda'_0(L)$ . More precisely,  $\Lambda'_0(L)$  is the image of

$$\sum_{\substack{P : \text{horizontal configuration with} \\ \text{two end points on each component of } L}} c_P(L) D_P,$$

which is equal to

$$\sum_{\substack{D : \\ \text{chord diagram with two end points} \\ \text{on each component}}} \left( \sum_{P : D_P = D} c_P(L) \right) D.$$

We first assume that  $L$  is a knot. In this case, we need the coefficient of  $D^{(1)} (= \Theta)$ , which is equal to  $\sum_{P : D_P = D^{(1)}} c_P(L)$ . From the description of  $Z_f$  by using a tangle decomposition in [17, 18], we know that the coefficient of  $\Theta$  in  $Z_f(L)$  is a half of the writhe  $w(L)$  of  $L$ . Hence, we have

$$(5.3) \quad \Lambda'_0(L) = \frac{w(L)}{2}.$$

Next, we assume that  $L$  is a two component algebraically split link with components  $L_1$  and  $L_2$ . In this case, we need the coefficients of  $D^{(2)}$  and  $D^{(1)} \sqcup D^{(1)}$ ,

which are given by the following integrals: The coefficient of  $D^{(2)}$  is

$$\frac{1}{(2\pi\sqrt{-1})^2} \int_{t_1 < t_2} \sum_{\substack{z_1 \in L_1 \cap \{t=t_1\}, z'_1 \in L_2 \cap \{t=t_1\} \\ z_2 \in L_1 \cap \{t=t_2\}, z'_2 \in L_2 \cap \{t=t_2\}}} \varepsilon_1 \varepsilon'_1 \varepsilon_2 \varepsilon'_2 d\log(z_1 - z'_1) \wedge d\log(z_2 - z'_2),$$

where  $\varepsilon_i$ , (resp.  $\varepsilon'_i$ ) is 1 if the link  $L$  is oriented upward at the point  $(t_i, z_i)$  (resp.  $(t_i, z'_i)$ ), and is equal to -1 if  $L$  is oriented downward at this point. This integral is equal to

$$\frac{1}{2} \left( \frac{1}{2\pi\sqrt{-1}} \int_{t_1} \sum_{\substack{z_1 \in L_1 \cap \{t=t_1\} \\ z'_1 \in L_2 \cap \{t=t_1\}}} \varepsilon_1 \varepsilon'_1 d\log(z_1 - z'_1) \right) \times \left( \frac{1}{2\pi\sqrt{-1}} \int_{t_2} \sum_{\substack{z_2 \in L_1 \cap \{t=t_2\} \\ z'_2 \in L_2 \cap \{t=t_2\}}} \varepsilon_2 \varepsilon'_2 d\log(z_2 - z'_2) \right).$$

As in [13], we know that

$$(5.4) \quad \frac{1}{2\pi\sqrt{-1}} \int_{t_1} \sum_{z \in L_1 \cap \{t=t_1\}, z' \in L_2 \cap \{t=t_1\}} \varepsilon_1 \varepsilon'_1 d\log(z - z') = \text{lk}(L_1, L_2),$$

and so the coefficient is equal to

$$\frac{1}{2} \text{lk}(L_1, L_2)^2 = 0,$$

since  $L$  is an algebraically split link. As in the case of knot, the coefficient of  $D^{(1)} \sqcup D^{(1)}$  is equal to

$$\frac{w(L_1)w(L_2)}{4}.$$

Hence we have

$$\Lambda'_0(L) = \frac{w(L_1)w(L_2)}{4}.$$

Now consider the case for  $\ell$ -component algebraically split link  $L$  with components  $L_1, L_2, \dots, L_\ell$  for  $\ell \geq 3$ . We first compute the coefficient of  $D^{(\ell)}$  whose components corresponding to  $L_1, \dots, L_\ell$  are connected by chords in that order. It is given by the following integral:

$$\frac{1}{(2\pi\sqrt{-1})^\ell} \int_{t_1, t_2, \dots, t_\ell} \sum_{\substack{z_1 \in L_1 \cap \{t=t_1\}, z'_1 \in L_2 \cap \{t=t_1\} \\ z_2 \in L_2 \cap \{t=t_2\}, z'_2 \in L_3 \cap \{t=t_2\} \\ \dots \\ z_\ell \in L_\ell \cap \{t=t_\ell\}, z'_\ell \in L_1 \cap \{t=t_\ell\}}} \bigwedge_{k=1}^{\ell} d\log(z_k - z'_k).$$



Let  $L_{\ell+1}$  denote  $L_1$ , then the above integral is equal to

$$\prod_{k=1}^{\ell} \frac{1}{2\pi\sqrt{-1}} \int_{t_k} \sum_{\substack{z \in L_k \cap \{t=t_k\} \\ z' \in L_{k+1} \cap \{t=t_k\}}} d\log(z - z').$$

Hence, the coefficient is equal to

$$\prod_{k=1}^{\ell} \text{lk}(L_k, L_{k+1}) = 0,$$

since  $L$  is an algebraically split link. Next we compute the coefficient of a disjoint union of several  $D^{(k)}$ 's. In this case, the result is a product of coefficients corresponding to every  $D^{(k)}$  given above, and so only the coefficient of  $\cup^{\ell} D^{(1)}$  does not vanish. Hence we get

$$\Lambda'_0(L) = \prod_{i=1}^{\ell} \frac{w(L_i)}{2}.$$

Therefore, from (1.1) and (1.2), we have

$$\begin{aligned} \Lambda_0(L) &= 2^{\ell - \sigma_+(L) - \sigma_-(L)} \left(\frac{1}{2}\right)^{-\sigma_+(L)} \left(-\frac{1}{2}\right)^{-\sigma_-(L)} \prod_{i=1}^{\ell} \frac{w(L_i)}{2} = \left| \prod_{i=1}^{\ell} w(L_i) \right| \\ &= |\det B_L|, \end{aligned}$$

since  $\sigma_+(L)$  and  $\sigma_-(L)$  are equal to the number of components of  $L$  with positive writhe and negative writhe respectively. This implies Theorem 2 (1) because  $|\det B_L|$  is equal to the order of the first homology group of  $M_L$  if  $b_1(M_L) = 0$ , and is equal to 0 if  $b_1(M_L) > 0$ . □

### 6. Coincidence with the Casson-Walker invariant

To show the equivalence of  $\Lambda_1$  and  $\tilde{\lambda}$ , it will be enough to show for knots and algebraically split links since we can apply Lemma 6 (diagonalization Lemma) in Section 4. For knots and algebraically split links, we derive skein relations of  $\Lambda_1$ , and compare them with the Lescop's formula for the Casson-Walker invariant.

Let  $L_1$  and  $L_2$  be two framed links. Assume that the linking matrix of  $L_2$  is non-degenerate. Let  $L_1 \sqcup L_2$  denote the split union of these two links. Then we have

$$(6.1) \quad \Lambda_1(L_1 \sqcup L_2) = \Lambda_0(L_2) \Lambda_1(L_1) + \Lambda_0(L_1) \Lambda_1(L_2).$$

On the other hand, [22] shows that, for a connected sum  $M_{L_1} \# M_{L_2}$ ,  $\tilde{\lambda}$  satisfies (6.2)

$$\tilde{\lambda}(M_{L_1} \# M_{L_2}) = \begin{cases} |H_1(M_{L_2})| \tilde{\lambda}(M_{L_1}) + |H_1(M_{L_1})| \tilde{\lambda}(M_{L_2}) & \text{if } b_1(M_{L_1}) = 0, \\ |H_1(M_{L_2})| \tilde{\lambda}(M_{L_1}) & \text{if } b_1(M_{L_1}) > 0. \end{cases}$$

We already know that  $\Lambda_0(L) = |H_1(M_L)|$  if  $b_1(M_L) = 0$ , and  $\Lambda_0(L) = 0$  if  $b_1(M_L) > 0$ . Therefore, if Theorem 2 (2) is true for certain link  $L_2$  with non-degenerate linking matrix, and for the split union  $L_1 \sqcup L_2$ , then it is also true for  $L_1$ . Hence, it is good enough to prove Theorem 2 (2) only for algebraically split links.

Next, we introduce skein relations for  $\Lambda_1$ .

**Lemma 7.** *Let  $L_+$  and  $L_-$  be two framed knots which are identical except in a small ball  $B$  where  $L_+ \cap B$  is a positive crossing and  $L_- \cap B$  is a negative crossing. Let  $\tilde{L}_-$  be the knot obtained from  $L_-$  by adding a positive full twist as in Figure 9. Let  $K^{(1)}$  and  $K^{(2)}$  be the components of the two component link obtained from  $L_+$  by the smoothing at the crossing in the ball  $B$ . Then  $\Lambda_1(L_+)$  and  $\Lambda_1(\tilde{L}_-)$  satisfy the following.*

(skein I)  $\Lambda_1(L_+) - \Lambda_1(\tilde{L}_-) = -6 \text{sign}(w(L_+)) \text{lk}(K^{(1)}, K^{(2)})$ .

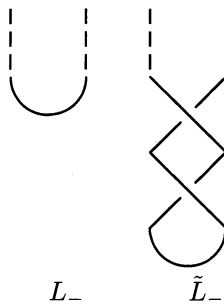

FIGURE 9. Adding full twist to  $L_-$ .

**Lemma 8.** *Let  $L_{+-} = L_{+-}^{(1)} \cup L_{+-}^{(2)} \cup L^{(3)} \cup \dots \cup L^{(\ell)}$  be an  $\ell$ -component algebraically split link with a positive crossing (resp. a negative crossing) consisting of the strings  $L_{+-}^{(1)}$  and  $L_{+-}^{(2)}$  in a small ball  $B_1$  (resp.  $B_2$ ). Let  $L_{-+} = L_{-+}^{(1)} \cup L_{-+}^{(2)} \cup L^{(3)} \cup \dots \cup L^{(\ell)}$  be a link obtained from  $L_{+-}$  by crossing changes in  $B_1$  and  $B_2$ . Let  $L_1$  be the link obtained from  $L_{+-}$  by smoothing at the crossing in the ball  $B_1$ , and*

let  $L_2$  be the link obtained from  $L_{-+}$  by smoothing at the crossing in the ball  $B_2$ . Then  $\Lambda_1(L_{+-})$  and  $\Lambda_1(L_{-+})$  satisfy the following.

(skein II)

$$\Lambda_1(L_{+-}) - \Lambda_1(L_{-+}) = -\text{sign}(w(L_{+-}^{(1)}) w(L_{+-}^{(2)}) w(L_1)) (\Lambda_1(L_1) - \Lambda_1(L_2)).$$

Proofs of Lemmas 7 and 8 are given in the next section.

For an  $\ell$ -component algebraically split link  $L = L_1 \cup L_2 \cup \dots \cup L_\ell$ , a Dehn surgery formula for the Casson invariant is obtained in [10, 21, 22], which is given by

(Dehn surgery formula)

$$\begin{aligned} \tilde{\lambda}(M_L) = & - \sum_{i=1}^{\ell} \text{sign}(w(L_i)) \left( \prod_{j \neq i} |w(L_j)| \right) \frac{(|w(L_i)| - 1)(|w(L_i)| - 2)}{12} + \\ & \sum_{I \subset \{1, 2, \dots, \ell\}} 2 \left( \prod_{i \in I} \text{sign}(w(L_i)) \right) \left( \prod_{i \notin I} |w(L_i)| \right) a_{|I|+1}(\cup_{i \in I} L_i). \end{aligned}$$

Here  $|I|$  denotes the number of elements in  $I$ , and  $a_k(L)$  is the coefficient of  $t^k$  in the Conway polynomial  $\nabla_L(t)$ , which is defined by the following skein relation:

$$\nabla_{L_+}(t) - \nabla_{L_-}(t) = -t \nabla_{L_0}(t),$$

where  $L_+$ ,  $L_-$ ,  $L_0$  are links identical except within a ball at which they are a positive crossing, negative crossing and their smoothing as usual. Note that there is a minus at the right hand side of the relation. Recall that, if  $M_L$  is a rational homology sphere,

$$\tilde{\lambda}(M_L) = |H_1(M_L)| \lambda(M_L) = \prod_{i=1}^{\ell} |w(L_i)| \lambda(M_L).$$

Before proving Theorem 2 (2), we show some properties of  $\tilde{\lambda}$  for three simple cases.

**Lemma 9.** *Lescop’s generalization of the Casson-Walker invariant  $\tilde{\lambda}$  satisfies the following.*

- (i) *For any trivial framed knot  $L$ ,  $-3 \tilde{\lambda}(M_L) = \Lambda_1(L)$ .*
- (ii) *For any knots  $L_+$ ,  $\tilde{L}_-$ ,  $K^{(1)}$  and  $K^{(2)}$  as in Lemma 7,*

$$\tilde{\lambda}(M_{L_+}) - \tilde{\lambda}(M_{\tilde{L}_-}) = 2 \text{sign}(w(L_+)) \text{lk}(K^{(1)}, K^{(2)}).$$

(iii) For any links  $L_{+-} = L_{+-}^{(1)} \cup L_{+-}^{(2)} \cup L^{(3)} \cup \dots \cup L^{(\ell)}$ ,  $L_{-+} = L_{-+}^{(1)} \cup L_{-+}^{(2)} \cup L^{(3)} \cup \dots \cup L^{(\ell)}$ ,  $L_1$  and  $L_2$  as in Lemma 8,

$$\tilde{\lambda}_1(M_{L_{+-}}) - \tilde{\lambda}_1(M_{L_{-+}}) = -\text{sign}(w(L_{+-}^{(1)}) w(L_{+-}^{(2)}) w(L_1)) \left( \tilde{\lambda}_1(M_{L_1}) - \tilde{\lambda}_1(M_{L_2}) \right).$$

This lemma is proved after proving Theorem 2 (2).

Proof of Theorem 2 (2). For an  $\ell$ -component algebraically split link  $L$  with non-degenerate linking matrix, we will prove that  $-3\tilde{\lambda}(M_L) = \Lambda_1(L)$ . The computation of  $\Lambda_1$  is reduced to those for split links by the relation (skein II). By using (6.1) and (6.2), the proof for a split link is reduced to the proof for each component. Moreover, by using (skein I),  $\Lambda_1$  of a knot is reduced to  $\Lambda_1$  of trivial knots with framings. Therefore, Lemmas 7, 8 and 9 show that  $\Lambda_1$  and  $-3\tilde{\lambda}$  satisfy the same recursive relations and the same initial conditions. Hence they are identical.  $\square$

Proof of Lemma 9. We first show (i). For a trivial framed knot  $L$  given by vertical twist as in Figure 10,

$$Z_f(L) = \bigcirc + \frac{w(L)}{2} \Theta + \frac{w(L)^2}{8} \Theta_2 + (\text{terms with more than two chords}),$$

and

$$\nu = \bigcirc + \frac{1}{24} (\Theta_2 - \textcircled{\text{⋮}}) + (\text{terms with more than two chords}).$$

Hence we have

$$\begin{aligned} \check{Z}_f(L) &= Z_f(L) \# \nu \# \nu \\ &= \bigcirc + \frac{w(L)}{2} \Theta + \frac{(3w(L)^2 + 2)\Theta_2 - 2\textcircled{\text{⋮}}}{24} \\ &\quad + (\text{terms with more than two chords}). \end{aligned}$$

In  $\mathcal{A}_1$ , we have

$$\bigcirc = 0, \quad \textcircled{\text{⋮}} = -2\Theta_2,$$

by the 0-vanishing formula and the 3T relation. Therefore, in  $\mathcal{A}_1$ , we have

$$(6.3) \quad \Lambda'(L) = \frac{w(L)}{2} e_0 + \frac{w(L)^2 + 2}{8} e_1,$$

and so

$$\begin{aligned} \Lambda(L) &= \left( \frac{w(L)}{2} e_0 + \frac{w(L)^2 + 2}{8} e_1 \right) \left( \text{sign}(w(L)) \frac{1}{2} e_0 + \frac{3}{8} e_1 \right)^{-1} \\ &= \left( \frac{w(L)}{2} e_0 + \frac{w(L)^2 + 2}{8} e_1 \right) \left( 2 \text{sign}(w(L)) e_0 - \frac{3}{2} e_1 \right) \\ &= |w(L)| e_0 + \text{sign}(w(L)) \frac{|w(L)|^2 - 3|w(L)| + 2}{4} e_1. \end{aligned}$$



FIGURE 10. trivial framed knot  $L$  with vertical twist

Hence

$$\Lambda_1(L) = \text{sign}(w(L)) \frac{|w(L)|^2 - 3|w(L)| + 2}{4}.$$

On the other hand, by the Dehn surgery formula of  $\tilde{\lambda}$  described before, we have

$$\tilde{\lambda}(M_L) = -\text{sign}(w(L)) \frac{|w(L)|^2 - 3|w(L)| + 2}{12}.$$

Hence (i) is true.

Now we show (ii). Since  $w(L_+) = w(\tilde{L}_-)$ ,

$$\tilde{\lambda}(M_{L_+}) - \tilde{\lambda}(M_{\tilde{L}_-}) = 2 \text{sign}(w(L_+)) \left( a_2(L_+) - a_2(\tilde{L}_-) \right).$$

From (4.7) in [7] and Theorem 2 in [8], we have

$$a_2(L_+) - a_2(\tilde{L}_-) = a_2(L_+) - a_2(L_-) = -a_1(K^{(1)} \cup K^{(2)}) = \text{lk}(K^{(1)}, K^{(2)}).$$

These two formulas imply (ii).

It remains to prove (iii). We use the notations in (skein II). Then, we have

$$(6.4) \quad \tilde{\lambda}(M_{L_{+-}}) - \tilde{\lambda}(M_{L_{-+}}) = 2 \sum_{J \subset \{3,4,\dots,\ell\}} \left( \prod_{i \in \{3,4,\dots,\ell\} \setminus J} |w(L^{(i)})| \right) \times \\ \left( a_{|J|+3}(L_{+-}^{(1)} \cup L_{+-}^{(2)} \cup (\cup_{j \in J} L^{(j)})) - a_{|J|+3}(L_{-+}^{(1)} \cup L_{-+}^{(2)} \cup (\cup_{j \in J} L^{(j)})) \right),$$

since the other terms of  $\tilde{\lambda}(M_{L_{+-}})$  are identical to the corresponding terms of  $\tilde{\lambda}(M_{L_{-+}})$ . Similarly, we have

$$(6.5) \quad \tilde{\lambda}(M_{L_1}) - \tilde{\lambda}(M_{L_2}) = 2 \sum_{J \subset \{3,4,\dots,\ell\}} \left( \prod_{i \in \{3,4,\dots,\ell\} \setminus J} |w(L^{(i)})| \right) \times \\ \left( a_{|J|+2}(L_1^{(1)} \cup (\cup_{j \in J} L^{(j)})) - a_{|J|+2}(L_2^{(1)} \cup (\cup_{j \in J} L^{(j)})) \right),$$

where  $L_1^{(1)}$  and  $L_2^{(1)}$  are components of  $L_1$  and  $L_2$  such that  $L_1 = L_1^{(1)} \cup L^{(3)} \cup \dots \cup L^{(\ell)}$  and  $L_2 = L_2^{(1)} \cup L^{(3)} \cup \dots \cup L^{(\ell)}$ . From the definition of  $\nabla$ , we have

(6.6)

$$a_{|J|+3}(L_{+-}^{(1)} \cup L_{+-}^{(2)} \cup (\bigcup_{j \in J} L^{(j)})) - a_{|J|+3}(L_{--}^{(1)} \cup L_{--}^{(2)} \cup (\bigcup_{j \in J} L^{(j)})) \\ = -a_{|J|+2}(L_1^{(1)} \cup (\bigcup_{j \in J} L^{(j)})),$$

(6.7)

$$a_{|J|+3}(L_{-+}^{(1)} \cup L_{-+}^{(2)} \cup (\bigcup_{j \in J} L^{(j)})) - a_{|J|+3}(L_{--}^{(1)} \cup L_{--}^{(2)} \cup (\bigcup_{j \in J} L^{(j)})) \\ = -a_{|J|+2}(L_2^{(1)} \cup (\bigcup_{j \in J} L^{(j)})).$$

We also know that

(6.8)

$$w(L_1^{(1)}) = w(L_2^{(1)}), \quad w(L_{+-}^{(1)}) = w(L_{-+}^{(1)}), \quad w(L_{+-}^{(2)}) = w(L_{-+}^{(2)}).$$

Hence, normalizing by the signatures of the writhes of  $L_1^{(1)}$ ,  $L_1^{(2)}$ ,  $L_{+-}^{(1)}$ ,  $L_{-+}^{(1)}$ ,  $L_{+-}^{(2)}$  and  $L_{-+}^{(2)}$ , we get (iii) from (6.4) ~ (6.8). □

### 7. Skein relation of $\Lambda_1$

We prove the skein relations Lemmas 7 and 8. These two lemmas are obtained from the following skein relations for  $\Lambda'_1$  by using the relation between  $\Lambda$  and  $\Lambda'$ .

**Lemma 10.** *Let  $L_+$ ,  $\tilde{L}_-$ ,  $K^{(1)}$  and  $K^{(2)}$  be as in Lemma 7. Then*

(skein I')

$$\Lambda'_1(L_+) - \Lambda'_1(L_-) = -3\text{lk}(K^{(1)}, K^{(2)}).$$

**Lemma 11.** *Let  $L_{+-}$ ,  $\tilde{L}_{-+}$ ,  $L_1$  and  $L_2$  be as in Lemma 8. Then*

(skein II')

$$\Lambda'_1(L_{+-}) - \Lambda'_1(L_{-+}) = -\frac{1}{2} (\Lambda'_1(L_1) - \Lambda'_1(L_2)).$$

Proof of Lemma 10. We separate  $\Lambda_1(L_+)$  and  $\Lambda_1(\tilde{L}_-)$  into the q-tangles corresponding to the crossing points in  $B$  and the added full twist, and the contribution from the other parts. Let  $P_{\pm}$  be the invariant  $\hat{Z}_f$  from the crossing,  $T$  be that from the full twist, and  $Q$  be that from the other part. Then,  $P_+$ ,  $P_-$  are given in [17] and

$$P_+ = \begin{array}{c} \diagup \quad \diagdown \\ \diagdown \quad \diagup \end{array} + \frac{\begin{array}{c} \text{---} \\ \diagup \quad \diagdown \\ \diagdown \quad \diagup \\ \text{---} \end{array}}{2} + \frac{\begin{array}{c} \text{---} \\ \diagup \quad \diagdown \\ \diagdown \quad \diagup \\ \text{---} \end{array}}{8} + \dots, \quad P_- = \begin{array}{c} \diagup \quad \diagdown \\ \diagdown \quad \diagup \end{array} - \frac{\begin{array}{c} \text{---} \\ \diagup \quad \diagdown \\ \diagdown \quad \diagup \\ \text{---} \end{array}}{2} + \frac{\begin{array}{c} \text{---} \\ \diagup \quad \diagdown \\ \diagdown \quad \diagup \\ \text{---} \end{array}}{8} - \dots.$$

The contribution of  $T$  is given by the connected sum of  $\bigcirc + \Theta + \Theta_2 + \dots$  to the integral of  $L_-$ . For a sum  $X$  of chord diagrams, let  $X^{(k)}$  denote the part of  $X$  consisting of the terms with diagrams having  $k$  chords. Since  $\check{Z}_f(K) = \hat{Z}_f(K) \# \nu$  for a knot  $K$ , we have

$$\begin{aligned} \Lambda'_1(L_+) &= P_+^{(0)} (Q \# \nu)^{(2)} + P_+^{(1)} (Q \# \nu)^{(1)} + P_+^{(2)} (Q \# \nu)^{(0)} \\ &= P_+^{(0)} (Q \# \nu)^{(2)} + P_+^{(1)} Q^{(1)} + P_+^{(2)} Q^{(0)}, \end{aligned}$$

$$\begin{aligned} \Lambda'_1(L_-) &= P_-^{(0)} (Q \# \nu)^{(2)} + P_-^{(1)} (Q \# \nu)^{(1)} + P_-^{(2)} (Q \# \nu)^{(0)} \\ &= P_-^{(0)} (Q \# \nu)^{(2)} + P_-^{(1)} Q^{(1)} + P_-^{(2)} Q^{(0)}, \end{aligned}$$

$$\begin{aligned} \Lambda'_1(\tilde{L}_-) &= P_-^{(0)} (Q \# \nu)^{(2)} T^{(0)} + P_-^{(1)} Q^{(1)} T^{(0)} + P_-^{(2)} Q^{(0)} T^{(0)} \\ &\quad + P_-^{(0)} Q^{(1)} T^{(1)} + P_-^{(1)} Q^{(0)} T^{(1)} + P_-^{(2)} Q^{(0)} T^{(2)} \\ &= P_-^{(0)} (Q \# \nu)^{(2)} + P_-^{(1)} Q^{(1)} + P_-^{(2)} Q^{(0)} \\ &\quad + (P_-^{(0)} Q^{(1)}) \# \Theta + (P_-^{(1)} Q^{(0)}) \# \Theta + (P_-^{(2)} Q^{(0)}) \# \Theta_2/2. \end{aligned}$$

Therefore, we have

$$\begin{aligned} \Lambda'_1(L_+) - \Lambda'_1(\tilde{L}_-) &= (P_+^{(0)} - P_-^{(0)}) (Q \# \nu)^{(2)} + (P_+^{(1)} - P_-^{(1)}) Q^{(1)} - (P_-^{(0)} Q^{(1)}) \# \Theta \\ &\quad + (P_+^{(2)} - P_-^{(2)}) Q^{(0)} - (P_-^{(1)} Q^{(0)}) \# \Theta - (P_-^{(2)} Q^{(0)}) \# \Theta_2/2. \end{aligned}$$

Since

$$\begin{aligned} (P_-^{(1)} Q^{(0)}) \# \Theta &= -\Theta_2/2, \\ (P_-^{(0)} Q^{(0)}) \# \Theta_2 &= \Theta_2/2, \\ (P_+^{(0)} - P_-^{(0)}) &= (P_+^{(2)} - P_-^{(2)}) = 0, \end{aligned}$$

we have

$$\begin{aligned} \Lambda'_1(L_+) - \Lambda'_1(\tilde{L}_-) &= (P_+^{(1)} - P_-^{(1)}) Q^{(1)} - (P_-^{(0)} Q^{(1)}) \# \Theta \\ &= \left( \begin{array}{c} \text{---} \\ \diagup \quad \diagdown \\ \text{---} \end{array} \right) \cup Q^{(1)} - \left( \begin{array}{c} \diagdown \quad \diagup \\ \text{---} \end{array} \right) \cup Q^{(1)} \# \Theta. \end{aligned}$$

We compute  $Q^{(1)}$  exactly. There are three kinds of chord diagrams in  $Q^{(1)}$  given in Figure 11. In this figure,  $s^{(1)}$  and  $s^{(2)}$  denote the two components of  $Q^{(1)}$  corresponding to  $K^{(1)}$  and  $K^{(2)}$  respectively. Let  $\alpha_1, \alpha_2, \alpha_3$  be the coefficient of the invariant  $\hat{Z}_f$  of the configurations to  $Q_1^{(1)}, Q_2^{(1)}, Q_3^{(1)}$ . Then, from (5.3) and (5.4), we have

$$\alpha_1 = w(K^{(1)})/2, \quad \alpha_2 = \text{lk}(K^{(1)}, K^{(2)}), \quad \alpha_3 = w(K^{(2)})/2.$$

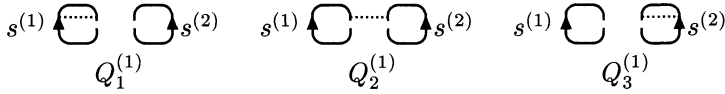

FIGURE 11. Chord diagrams in  $Q^{(1)}$ , where  $s^{(i)}$  denote the string corresponding to  $K^{(i)}$ .

Hence  $(\Lambda'_1(L_+) - \Lambda'_1(\tilde{L}_-))g_1$  is equal to the image in  $\mathcal{A}_1$  of

$$\frac{w(K^{(1)}) + w(K^{(2)})}{2} \Theta_2 + \text{lk}(K^{(1)}, K^{(2)}) \left( \bigoplus_{\text{dots}} \right) - \frac{w(K^{(1)}) + 2\text{lk}(K^{(1)}, K^{(2)}) + w(K^{(2)})}{2} \Theta_2 = -3\text{lk}(K^{(1)}, K^{(2)})e_1.$$

Here we use the relation  $\left( \bigoplus_{\text{dots}} \right) = -2\Theta_2$ . So we get Lemma 10. □

Proof of Lemma 11.

Let  $L_{+-} = L_{+-}^{(1)} \cup L_{+-}^{(2)} \cup L^{(3)} \cup \dots \cup L^{(\ell)}$ ,  $L_{-+} = L_{-+}^{(1)} \cup L_{-+}^{(2)} \cup L^{(3)} \cup \dots \cup L^{(\ell)}$ ,  $L_1, L_2, B_1$  and  $B_2$  are as in Lemma 8 and let  $L_{--} = L_{--}^{(1)} \cup L_{--}^{(2)} \cup L^{(3)} \cup \dots \cup L^{(\ell)}$  be a link obtained from  $L_{+-}$  by a crossing change in  $B_1$ . Note that  $L_{-+}$  is an algebraically split link since so is  $L_{+-}$ .

We first compute  $\Lambda'_1(L_{+-}) - \Lambda'_1(L_{--})$ . We express  $\Lambda'_1(L_{+-}) - \Lambda'_1(L_{--})$  in terms of  $\Lambda'_1(L_1)$ . Let  $P_+, P_-, P_1$  denote  $\hat{Z}_f$  of the q-tangles corresponding to the parts of  $L_+, L_-, L_1$  in  $B_1$ , and  $Q$  be  $\hat{Z}_f$  form the other part. Note that  $Q$  is the same one for  $L_+, L_-, L_1$  because  $L_+, L_-$  and  $L_1$  are identical in the complement of  $B_1$ . We know that

$$P_+ = \text{diagram} + \frac{\text{diagram}}{2} + \frac{\text{diagram}}{8} + \dots, \quad P_- = \text{diagram} - \frac{\text{diagram}}{2} + \frac{\text{diagram}}{8} - \dots, \quad P_1 = \text{diagram} \mid \mid$$

Let  $X^{(k)}$  denote the part consisting of terms with diagrams having  $k$  chords as before. Since, for any framed link  $L$ ,  $\check{Z}_f(L)$  is obtained from  $\hat{Z}_f(L)$  by adding  $\nu$  to each component by the connect sum, we have

$$\Lambda'_1(L_{+-}) - \Lambda'_1(L_{--}) = \text{diagram} \cup (Q \# (\nu, \dots, \nu))^{(\ell)},$$

$$\Lambda'_1(L_1) = \text{diagram} \mid \mid \cup (Q \# (\nu, \dots, \nu))^{(\ell)}.$$

The integral corresponding to a middle chord of the part  $\dots \bigcirc \dots \bigcirc \dots$  is given by the linking number of two components of the link corresponding to the component containing the end points of the middle chord. We assumed that  $L_{+-}$  is an algebraically split link, hence the integral corresponding to a chord diagram containing a part  $\dots \bigcirc \dots \bigcirc \dots$  vanishes. By using this, we list up in Figure 12. all



the chord diagrams of  $(Q\#(\nu, \dots, \nu))^{(\ell)}$  which do not vanish. In this figure,  $s^{(1)}$ ,  $s^{(2)}$ ,  $s^{(i)}$  denote the components of  $(Q\#(\nu, \dots, \nu))^{(\ell)}$  corresponding to  $L_{\pm-}^{(1)}$ ,  $L_{\pm-}^{(2)}$  and  $L^{(i)}$  respectively. Let  $Q_1^{(i,j)}, \dots, Q_{33}(D_1^{(\ell-2)})$  be the diagrams in Figure 12. In this figure,  $\Theta^k = \sqcup^k \Theta$ .

Case that the number of end points of chords on  $s^{(1)}$  and  $s^{(2)}$  are equal to 4,

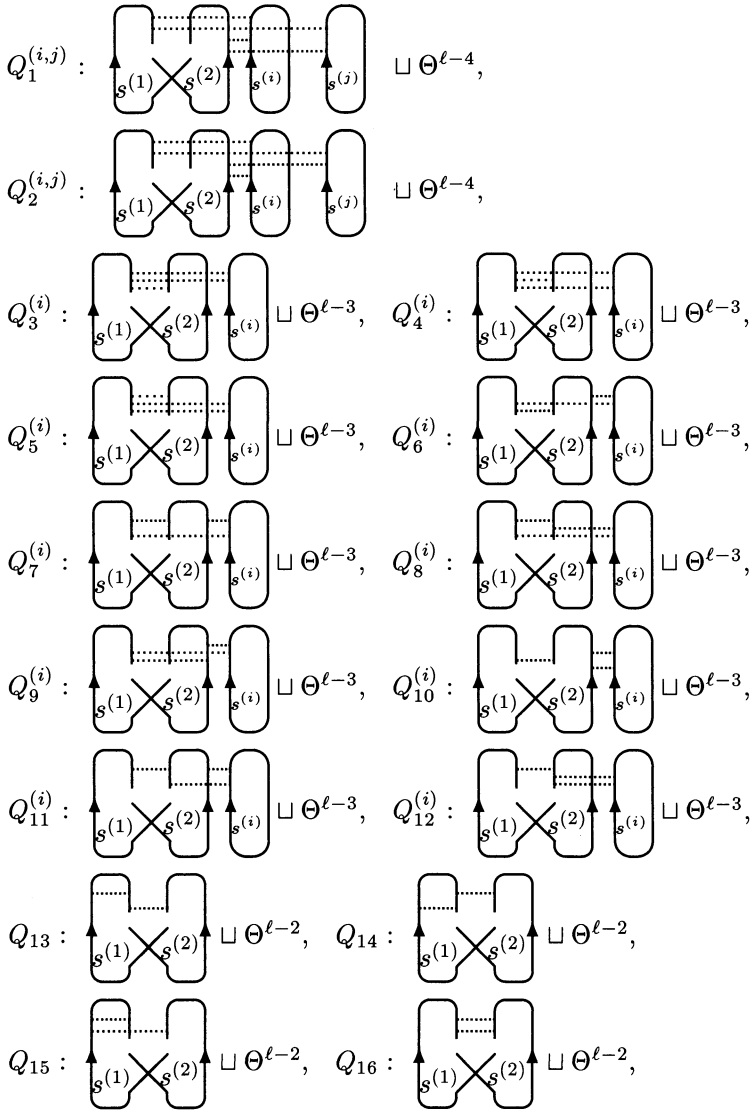

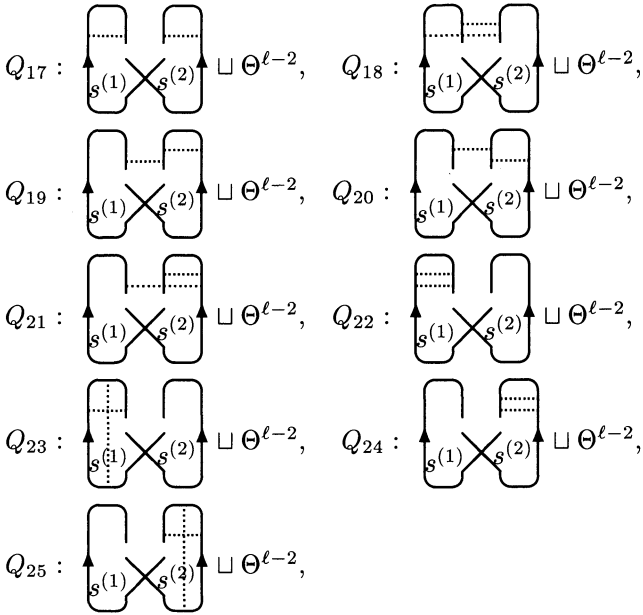

Case that the number of end points of chords on  $s^{(1)}$  and  $s^{(2)}$  are equal to 3,

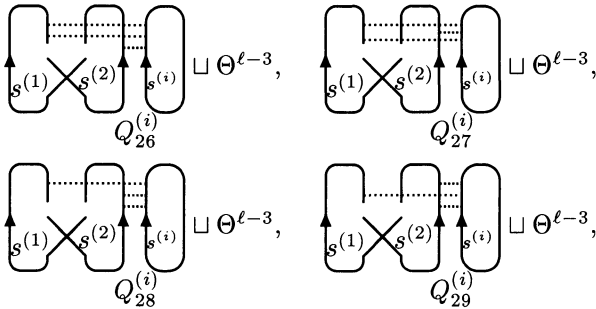

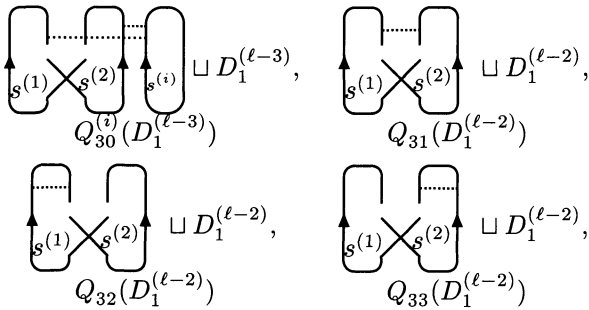

Case that the number of end points of chords on  $s^{(1)}$  and  $s^{(2)}$  are equal to 2,



where  $D_1^{(k)}$  is a non-vanishing chord diagram of degree 1 with  $k$  components.

FIGURE 12. Non-vanishing chord diagrams in  $Q^\ell$  for an algebraically split link

Let  $E_1^{(i,j)}, \dots, E_{33}(D_1^{(\ell-2)})$  be diagrams obtained by inserting  to  $Q_1^{(i,j)}, \dots, Q_{33}(D_1^{(\ell-2)})$ , and let  $F_1^{(i,j)}, \dots, F_{33}(D_1^{(\ell-2)})$  be diagrams obtained by inserting  to  $Q_1^{(i,j)}, \dots, Q_{33}(D_1^{(\ell-2)})$ . By using relations in  $\mathcal{A}_1^{(\ell)}, E_1^{(i,j)}, \dots, F_{33}(D_1^{(\ell-2)})$  are reduced as in Table 1. In the table,  $\Theta_2^{(k)} = (\sqcup^{k-1} \Theta) \sqcup \Theta_2$  and  $\Theta^k = \sqcup^k \Theta$ .

$$\begin{aligned}
 E_1^{(i,j)} &= -\frac{3}{16} \Theta_2^{(\ell)}, & E_2^{(i,j)} &= \frac{3}{16} \Theta_2^{(\ell)}, & E_3^{(i)} &= \frac{1}{4} \Theta_2^{(\ell)}, & E_4^{(i)} &= -\frac{1}{2} \Theta_2^{(\ell)}, \\
 E_5^{(i)} &= \frac{1}{4} \Theta_2^{(\ell)}, & E_6^{(i)} &= -\frac{3}{8} \Theta_2^{(\ell)}, & E_7^{(i)} &= \frac{3}{8} \Theta_2^{(\ell)}, & E_8^{(i)} &= -\frac{3}{8} \Theta_2^{(\ell)}, \\
 E_9^{(i)} &= \frac{3}{8} \Theta_2^{(\ell)}, & E_{10}^{(i)} &= \frac{1}{4} \Theta_2^{(\ell)}, & E_{11}^{(i)} &= -\frac{1}{2} \Theta_2^{(\ell)}, & E_{12}^{(i)} &= \frac{1}{4} \Theta_2^{(\ell)}, \\
 E_{13} &= -\frac{1}{2} \Theta_2^{(\ell)}, & E_{14} &= \Theta_2^{(\ell)}, & E_{15} &= -\frac{1}{2} \Theta_2^{(\ell)}, & E_{16} &= \frac{3}{4} \Theta_2^{(\ell)}, \\
 E_{17} &= 0, & E_{18} &= -\frac{3}{4} \Theta_2^{(\ell)}, & E_{19} &= -\frac{1}{2} \Theta_2^{(\ell)}, & E_{20} &= \Theta_2^{(\ell)}, \\
 E_{21} &= -\frac{1}{2} \Theta_2^{(\ell)}, & E_{22} &= 0, & E_{23} &= 0, & E_{24} &= 0, \\
 E_{25} &= 0, & E_{26}^{(i)} &= \frac{3}{8} \Theta_2^{(\ell)}, & E_{27}^{(i)} &= -\frac{3}{8} \Theta_2^{(\ell)}, & E_{28}^{(i)} &= -\frac{3}{8} \Theta_2^{(\ell)}, \\
 E_{29}^{(i)} &= \frac{3}{8} \Theta_2^{(\ell)}, & E_{30}^{(i)}(D_1^{(\ell-3)}) &= \frac{1}{4} D_1^{(\ell-3)} \sqcup \Theta^3, & E_{31}(D_1^{(\ell-2)}) &= -\frac{1}{2} D_1^{(\ell-2)} \sqcup \Theta^2, \\
 E_{32}(D_1^{(\ell-2)}) &= 0, & E_{33}(D_1^{(\ell-2)}) &= 0, \\
 \\
 F_1^{(i,j)} &= \frac{1}{4} \Theta_2^{(\ell-1)}, & F_2^{(i,j)} &= -\frac{1}{2} \Theta_2^{(\ell-1)}, & F_3^{(i)} &= -\frac{1}{2} \Theta_2^{(\ell-1)}, & F_4^{(i)} &= \Theta_2^{(\ell-1)}, \\
 F_5^{(i)} &= -\frac{1}{2} \Theta_2^{(\ell-1)}, & F_6^{(i)} &= \Theta_2^{(\ell-1)}, & F_7^{(i)} &= -\frac{1}{2} \Theta_2^{(\ell-1)}, & F_8^{(i)} &= \Theta_2^{(\ell-1)}, \\
 F_9^{(i)} &= -\frac{1}{2} \Theta_2^{(\ell-1)}, & F_{10}^{(i)} &= -\frac{1}{2} \Theta_2^{(\ell-1)}, & F_{11}^{(i)} &= \Theta_2^{(\ell-1)}, & F_{12}^{(i)} &= -\frac{1}{2} \Theta_2^{(\ell-1)}, \\
 F_{13} &= \Theta_2^{(\ell-1)}, & F_{14} &= -2 \Theta_2^{(\ell-1)}, & F_{15} &= \Theta_2^{(\ell-1)}, & F_{16} &= -2 \Theta_2^{(\ell-1)}, \\
 F_{17} &= \Theta_2^{(\ell-1)}, & F_{18} &= \Theta_2^{(\ell-1)}, & F_{19} &= \Theta_2^{(\ell-1)}, & F_{20} &= -2 \Theta_2^{(\ell-1)}, \\
 F_{21} &= \Theta_2^{(\ell-1)}, & F_{22} &= \Theta_2^{(\ell-1)}, & F_{23} &= -2 \Theta_2^{(\ell-1)}, & F_{24} &= \Theta_2^{(\ell-1)}, \\
 F_{25} &= -2 \Theta_2^{(\ell-1)}, & F_{26}^{(i)} &= -\frac{3}{4} \Theta_2^{(\ell-1)}, & F_{27}^{(i)} &= \frac{3}{4} \Theta_2^{(\ell-1)}, & F_{28}^{(i)} &= \frac{3}{4} \Theta_2^{(\ell-1)}, \\
 F_{29}^{(i)} &= -\frac{3}{4} \Theta_2^{(\ell-1)}, & F_{30}^{(i)}(D_1^{(\ell-3)}) &= -\frac{1}{2} D_1^{(\ell-3)} \sqcup \Theta^2, & F_{31}(D_1^{(\ell-2)}) &= D_1^{(\ell-2)} \sqcup \Theta, \\
 F_{32}(D_1^{(\ell-2)}) &= D_1^{(\ell-2)} \sqcup \Theta, & F_{33}(D_1^{(\ell-2)}) &= D_1^{(\ell-2)} \sqcup \Theta.
 \end{aligned}$$

Table 1

Let  $\alpha_k^{(i,j)}$  (resp.  $\alpha_k^{(i)}, \alpha_k, \alpha_k^{(i)}(D_1^{(\ell-3)}), \alpha_k(D_1^{(\ell-2)})$ ) denote the coefficient of  $\check{Z}_f$  of the configuration  $Q_k^{(i,j)}$  (resp.  $Q_k^{(i)}, Q_k, Q_k^{(i)}(D_1^{(\ell-3)}), Q_k(D_1^{(\ell-2)})$ ), then we have

$$\begin{aligned} \Lambda'_1(L_{+-}) - \Lambda'_1(L_{--}) + \frac{1}{2} \Lambda'_1(L_1) = & \\ & \sum_{3 \leq i < j \leq \ell} \left( -\frac{\alpha_1^{(i,j)}}{16} - \frac{\alpha_2^{(i,j)}}{16} \right) + \sum_{3 \leq i \leq \ell} \left( \frac{\alpha_6^{(i)}}{8} + \frac{\alpha_7^{(i)}}{8} + \frac{\alpha_8^{(i)}}{8} + \frac{\alpha_9^{(i)}}{8} \right) \\ & - \frac{\alpha_{16}}{4} + \frac{\alpha_{17}}{2} - \frac{\alpha_{18}}{4} + \frac{\alpha_{22}}{2} - \alpha_{23} + \frac{\alpha_{24}}{2} - \alpha_{25} \\ & + \sum_{D_1^{(\ell-2)}} \left( \frac{\alpha_{32}(D_1^{(\ell-2)})}{2} + \frac{\alpha_{33}(D_1^{(\ell-2)})}{2} \right). \end{aligned}$$

We know that

$$\alpha_1^{(i,j)} + \alpha_2^{(i,j)} = \text{lk}(L_{+-}^{(1)}, L^{(i)}) \text{lk}(L_{+-}^{(1)}, L^{(j)}) \text{lk}(L_{+-}^{(2)}, L^{(i)}) \text{lk}(L_{+-}^{(2)}, L^{(j)}),$$

and so it is equal to 0 because  $L_{+-}$  is an algebraically split link. Similarly, we have

$$\begin{aligned} \alpha_6^{(i)} + \alpha_7^{(i)} + \alpha_8^{(i)} + \alpha_9^{(i)} & \\ = \left( \text{lk}(L_{+-}^{(1)}, L_{+-}^{(2)}) - \frac{1}{2} \right) \text{lk}(L_{+-}^{(1)}, L^{(i)}) \text{lk}(L_{+-}^{(2)}, L^{(i)}) \text{lk}(L^{(i)}, L^{(j)}) & = 0, \end{aligned}$$

and

$$\alpha_{16} + \alpha_{18} = \left( \text{lk}(L_{+-}^{(1)}, L_{+-}^{(2)}) - \frac{1}{2} \right)^2 = 0.$$

We also know that

$$\alpha_{17} = \left( \prod_{j=3}^{\ell} \frac{w(L^{(j)})}{2} \right) \frac{w(L_{+-}^{(1)}) w(L_{+-}^{(2)})}{4}.$$

Moreover,

$$\alpha_{22} - 2\alpha_{23} = \Lambda'_1(L_{+-}^{(1)}) \left( \prod_{j=3}^{\ell} \frac{w(L^{(j)})}{2} \right), \quad \alpha_{24} - 2\alpha_{25} = \Lambda'_1(L_{+-}^{(2)}) \left( \prod_{j=3}^{\ell} \frac{w(L^{(j)})}{2} \right),$$

and

$$\sum_{D_1^{(\ell-2)}} \alpha_{32}(D_1^{(\ell-2)}) = \Lambda'_1(L') \frac{w(L_{+-}^{(1)})}{2}, \quad \sum_{D_1^{(\ell-2)}} \alpha_{33}(D_1^{(\ell-2)}) = \Lambda'_1(L') \frac{w(L_{+-}^{(2)})}{2},$$

where  $L' = L^{(3)} \cup L^{(4)} \cup \dots \cup L^{(\ell)}$ . Hence, we have

$$\begin{aligned} & \Lambda'_1(L_{+-}) - \Lambda'_1(L_{--}) + \frac{1}{2} \Lambda'_1(L_1) \\ &= \frac{w(L_{+-}^{(1)})w(L_{+-}^{(2)}) + 2\Lambda'_1(L_{+-}^{(1)}) + 2\Lambda'_1(L_{+-}^{(2)})}{8} \left( \prod_{j=3}^{\ell} \frac{w(L^{(j)})}{2} \right) \\ & \quad + \frac{\Lambda'_1(L')}{4} \left( w(L_{+-}^{(1)}) + w(L_{+-}^{(2)}) \right). \end{aligned}$$

Similarly, we have

$$\begin{aligned} & \Lambda'_1(L_{-+}) - \Lambda'_1(L_{--}) + \frac{1}{2} \Lambda'_1(L_2) = \\ & \frac{w(L_{-+}^{(1)})w(L_{-+}^{(2)}) + 2\Lambda'_1(L_{-+}^{(1)}) + 2\Lambda'_1(L_{-+}^{(2)})}{8} \left( \prod_{j=3}^{\ell} \frac{w(L^{(j)})}{2} \right) \\ & \quad + \frac{\Lambda'_1(L')}{4} \left( w(L_{-+}^{(1)}) + w(L_{-+}^{(2)}) \right). \end{aligned}$$

Since  $L_{+-}^{(i)}$  and  $L_{-+}^{(i)}$  are of the same knot type for  $i = 1$  and  $2$ , we get Lemma 11 by subtracting the above two formulas. □

---

**References**

- [1] S. Akbulut and J. D. McCarthy: *Casson's invariant for oriented homology 3-spheres - An Exposition*, Mathematical Notes **36**, Princeton University Press, Princeton, NJ, 1990.
- [2] D. Bar-Natan: *On the Vassiliev knot invariants*, Topology **34** (1995), 423-472.
- [3] D. Bar-Natan: *Non-associative tangles*, Geometric Topology (Athens, GA), 139-183, AMS/IP Stud. Adv. Math., 2.1, Amer. Math. Soc., Providence, RI, 1997.
- [4] J. H. Conway: An enumeration of knots and links, and some of their algebraic properties, in 'Computational Problems in Abstract Algebra', Pergamon Press, Exeter, 1969.
- [5] V. G. Drinfel'd: *On quasi-Hopf algebras*, Leningrad Math. J. **1** (1990), 1419-1457.
- [6] V. G. Drinfel'd: *On quasi-triangular quasi-Hopf algebras and a group closely connected with Gal(Q/Q)*, Leningrad Math. J. **2** (1991), 829-860.
- [7] R. Hartley: *The Conway potential function for links*, Comment. Math. Helv. **58** (1983), 365-378.
- [8] J. Hoste: *The first coefficient of the Conway polynomial*, Proc. Amer. Math. Soc. **95** (1985), 299-302.
- [9] J. Hoste: *A formula for Casson's invariant*, Trans. Amer. Math. Soc. **297** (1986), 547-562.
- [10] K. Ishibe: *A Dehn surgery formula for Walker invariant on a link*, Tokyo J. Mathematics, **17** (1994), 359-372.
- [11] V. F. R. Jones: *Hecke algebra representations of braid groups and link polynomials*, Ann. of Math. **126** (1987), 335-388.
- [12] C. R. Kirby: *A calculus for framed links in S<sup>3</sup>*, Invent. Math. **45** (1978), 35-56.

- [13] M. Kontsevich: *Vassiliev's knot invariants*, in 'Collection: I. M. Gelfand Seminar', Adv. Soviet Math. **16**, Part 2, Amer. Math. Soc., Providence, RI, 1993, pp. 137–150.
- [14] Le T. Q. T. , H. Murakami, J. Murakami and T. Ohtsuki: *Three manifold invariant derived from universal Vassiliev-Kontsevich invariant*, Proc. Japan Acad. Ser. A Math. Sci. **71** (1995), 125–127.
- [15] T. Q. T. Le and J. Murakami: *Kontsevich's integral for the HOMFLY polynomial and relations between values of multiple zeta functions*, Topology Appl. **62** (1995), 193-206.
- [16] T. Q. T. Le and J. Murakami: *Kontsevich integral for the Kauffman polynomial*, Nagoya Math. J. **142** (1996), 39–65.
- [17] Le T. Q. T. and J. Murakami: *Representations of the category of tangles by Kontsevich's iterated integral*, Comm. Math. Phys. **168** (1995), 535–562.
- [18] T. Q. T. Le and J. Murakami: *The universal Vassiliev-Kontsevich invariant for framed oriented links*, Compositio Math. **102** (1996), 41–64.
- [19] Le T. Q. T. and J. Murakami: *Parallel version of the universal Vassiliev-Kontsevich invariant*, J. Pure Appl. Algebra, **121** (1997), 271-291.
- [20] T. Q. T. Le, J. Murakami and T. Ohtsuki: *On a universal perturbative invariant of 3-manifolds*, Topology, **37** (1998), 539-574.
- [21] C. Lescop: *Un algorithme pour calculer l'invariant de Walker*, Bull. Soc. Math. France, **118** (1990), 363–376.
- [22] C. Lescop: *Sur l'invariant de Casson-Walker: formule de chirurgie globale et generalisation aux varietes de dimension 3 fermees orientees*, C. R. Acad. Sci. Paris Ser. I Math., **315** (1992), 437–440.
- [23] W. B. R. Lickorish: *A representation of oriented combinatorial 3-manifolds*, Ann. of Math. **76** (1962), 531–540.
- [24] W. B. R. Lickorish: *Three-manifolds and the Temperley-Lieb algebra*, Math. Ann. **290** (1991), 657–670.
- [25] H. Murakami: *Quantum  $SO(3)$ -invariants dominate the  $SU(2)$ -invariant of Casson and Walker*, Math. Proc. Cambridge Philos. Soc. **117** (1995), 237-249.
- [26] T. Ohtsuki: *A polynomial invariant of rational homology 3-spheres*, Math. Proc. Camb. Phil. Soc. **117** (1995), 83-112.
- [27] N. Reshetikhin and V. G. Turaev: *Invariants of 3-manifolds via link polynomials and quantum groups*, Invent. Math. **103** (1991), 547–597.
- [28] E. Witten: *Quantum field theory and the Jones polynomial*, Comm. Math. Phys. **121** (1989), 351–399.

T.T.Q.Le  
 Department of Mathematics,  
 SUNY at Buffalo,  
 Buffalo, NY 14214, USA

H.Murakami  
 Department of Mathematics,  
 Waseda University,  
 Nishiwaseda, Shinjuku-ku, Tokyo 169-8555, Japan

J. Murakami

Department of Mathematics,

Osaka University,

Machikaneyama-cho, Toyonaka, Osaka 560-0043, Japan,

e-mail address: jun@math.sci.osaka-u.ac.jp

T. Ohtsuki

Department of Mathematical and Computing Sciences,

Tokyo Institute of Technology,

Ookayama, Meguro-ku, Tokyo 152-8552, Japan

