

# The Atkin inner product for $\Gamma_0(N)$

By

Hiroyuki TSUTSUMI

## 1. Introduction

Let  $\mathfrak{H}$  be the complex upper half plane and  $\mathcal{M}$  the  $\mathbb{C}$ -vector space of  $SL_2(\mathbb{Z})$ -invariant functions which are holomorphic on  $\mathfrak{H}$  and meromorphic at  $i\infty$ . The space  $\mathcal{M}$  can be identified with the polynomial ring  $\mathbb{C}[j]$  via  $j = j(\tau)$ , where  $j(\tau)$  is the elliptic modular invariant:

$$j(\tau) = \frac{1}{q} + 744 + 196884q + 21493760q^2 + 864299970q^3 + \dots, \quad q = e^{2\pi i\tau}.$$

On the space  $\mathcal{M}$  act the Hecke operators  $\{T_n\}_{n \in \mathbb{N}}$ , and on  $\mathbb{C}[j]$  too, through the above identification.

A.O.L Atkin defined an inner product  $(\ , \ )$  on  $\mathcal{M}$  by

$$(f, g) = \text{constant term of } f \cdot g E_2 \text{ as Laurent series in } q = e^{2\pi i\tau},$$

where  $E_2(\tau)$  is the Eisenstein series of weight 2 for  $SL_2(\mathbb{Z})$ :

$$E_2(\tau) = 1 - 24 \sum_{m=1}^{\infty} \left( \sum_{d|m} d \right) q^m.$$

Atkin showed:

1. The Hecke operators  $T_n$  are self-adjoint with respect to this inner product;

$$(f|T_n, g) = (f, g|T_n), \quad \forall f, g \in \mathcal{M}, \forall n \geq 1.$$

2. The inner product is non-degenerate and the associated orthogonal polynomials are connected to the  $j$ -invariants of supersingular elliptic curves. (For precise statement, see the article [5].)

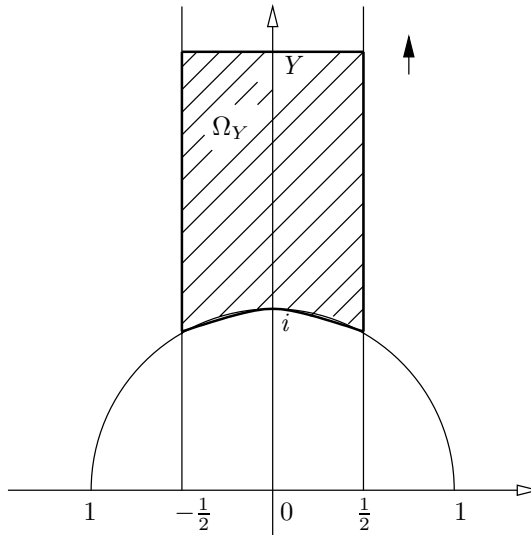

Figure 1: Fundamental domain of  $SL_2(\mathbb{Z})$  and  $\Omega_Y$

Atkin’s inner product is uniquely determined up to scalar multiple by the self-adjointness of the Hecke operators and by requiring the value  $(f, g)$  which depends only on the product  $fg$ .

From the self-adjointness with the Hecke operators, one may think the Atkin inner product as an analogue of the Petersson inner product on the space of cusp forms of positive weight. In fact, Borchers, suggested by work of physicists, showed that the Atkin inner product can be given by an integral similar to the Petersson product.

**Theorem** (Borchers [1]). *We use the notation  $(, )$  as the Atkin inner product, then*

$$(f, g) = \frac{1}{\text{vol}(SL_2(\mathbb{Z}) \backslash \mathfrak{H})} \lim_{Y \rightarrow \infty} \int_{\Omega_Y} f \cdot g \frac{dx dy}{y^2}, \quad (\tau = x + iy)$$

where  $\Im(\tau)$  is the imaginary part of  $\tau \in \mathfrak{H}$ ,  $\Re(\tau)$  the real part and

$$\Omega_Y = \left\{ \tau \in \mathfrak{H} \mid -\frac{1}{2} \leq \Re(\tau) \leq \frac{1}{2}, |\tau| \geq 1, \Im(\tau) \leq Y \right\}.$$

(See Figure 1.)

In this paper, we shall define a generalization of this inner product for  $SL_2(\mathbb{Z})$  to the one for congruence subgroups

$$\Gamma_0(N) = \left\{ \begin{pmatrix} a & b \\ c & d \end{pmatrix} \in SL_2(\mathbb{Z}) \mid c \equiv 0 \pmod{N} \right\}.$$

Then we prove the self-adjointness of the Hecke operators (Theorem 1) and a theorem of Borcherds’s type (Theorem 2).

We note that, for congruence subgroups, the self-adjointness of the Hecke operators does not necessarily determine the inner product uniquely. So Theorem 2 claims the “properness” of our definition of the inner product. We shall give our definition and theorems in Section 2. The proof for Theorems 1 and 2 will be given in Section 4 and 5 respectively. In these proofs, a transformation formula of the Eisenstein series of weight 2 for  $\Gamma_0(N)$  at  $i\infty$  plays an essential role. Although it is derived by a standard method, we shall give a detailed account of the transformation formula and related matters in Section 3.

In the final section, we study the new inner product from the function-theoretical view point. In particular the representation theory of the holomorphic functional on the open Riemann surface.

### 2. Definition and main theorems

We start from the definition of the Atkin inner product for  $\Gamma_0(N)$ .

**Definition.** Let  $\mathcal{M}^{(N)}$  be the set of modular functions for  $\Gamma_0(N)$  which are holomorphic on  $\mathfrak{H}$  and at all cusps except for  $i\infty$ , and meromorphic at  $i\infty$ . For  $f, g \in \mathcal{M}^{(N)}$ , we define “the Atkin inner product for  $\Gamma_0(N)$  at  $i\infty$ ” by

$$(f, g)_{(N)} = \text{constant term of } f \cdot g E_2^{(N)} \text{ as Laurent series in } q,$$

where  $E_2^{(N)}$  is the Eisenstein series of weight 2 for  $\Gamma_0(N)$  at  $i\infty$  defined by the following  $q$ -expansion:

$$(1) \quad E_2^{(N)}(\tau) = \prod_{\substack{p|N \\ p:\text{prime}}} \frac{p^2}{p^2-1} \sum_{e|N} \frac{\mu(e)}{e^2} \left( 1 - 24 \sum_{m=0}^{\infty} \left( \sum_{d|m} d \right) q^{\frac{N}{e}m} \right),$$

where  $\mu$  is the Möbius function.

For  $k \geq 3$ , the Eisenstein series of weight  $k$  for  $\Gamma_0(N)$  at  $i\infty$  is defined by,

$$(2) \quad E_k^{(N)}(\tau) = \frac{1}{2} \sum_{\substack{c,d \in \mathbb{Z} \\ (cN,d)=1}} \frac{1}{(cN\tau + d)^k}.$$

The above  $q$ -expansion of  $E_2^{(N)}$  is the series which is obtained by putting  $k = 2$  of the  $q$ -expansion of  $E_k^{(N)}$  ( $k \geq 3$ ) formally. Since  $|q| < 1$ , it is easy to see that the formal power series (1) is absolutely convergent.

Next, the two Theorems generalize Atkin’s Theorem (1) and Borcherd’s theorem.

**Theorem 1.** Let  $\{T_n^{(N)}\}_{n \geq 0}$  be the Hecke operators for  $\Gamma_0(N)$ . Suppose  $n$  and  $N$  are relatively prime integers. Then, for  $f, g \in \mathcal{M}^{(N)}$ ,

$$(f|T_n^{(N)}, g)_{(N)} = (f, g|T_n^{(N)})_{(N)}.$$

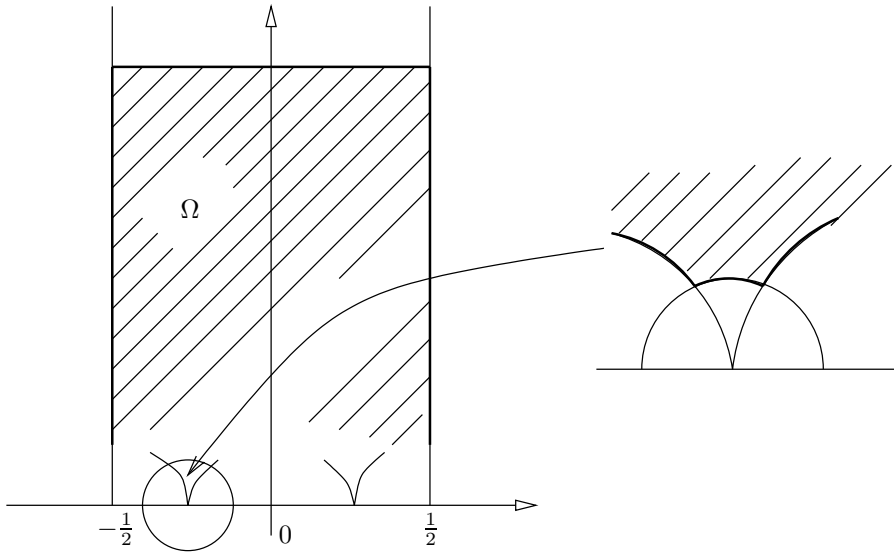

Figure 2: Fundamental domain of  $\Gamma_0(N)$  and  $\Omega$

**Theorem 2.** For  $f, g \in \mathcal{M}^{(N)}$ , the Atkin inner product for  $\Gamma_0(N)$  at  $i\infty$  has the following relation with the Poincaré metric.

$$(f, g)_{(N)} = \frac{1}{\text{vol}(\Gamma_0(N) \setminus \mathfrak{H})} \lim_{\Omega \rightarrow \mathcal{F}} \int_{\Omega} f \cdot g \frac{dx dy}{y^2},$$

where  $\mathcal{F}$  is a special fundamental domain of  $\Gamma_0(N)$  which is symmetrical with respect to the imaginary axis,  $\Omega$  is the subdomain of  $\mathcal{F}$  which we get by cutting down from  $\mathcal{F}$  neighborhoods of cusps bounded by the line the parallel to the real axis and the small circles with center at each finite cusp, and  $\Omega \rightarrow \mathcal{F}$  means bringing the line parallel to the real axis near to  $i\infty$  and the radiuses of circles near to zero. (See Figure 2.)

The following formula is the transformation formula of the Eisenstein series  $E_2^{(N)}$  which plays an essential role in proofs of above theorems.

**Proposition.** Let  $\tau \in \mathfrak{H}$ , and  $\begin{pmatrix} a & b \\ c & d \end{pmatrix} \in \Gamma_0(N)$ , then,

$$E_2^{(N)}\left(\frac{a\tau + b}{c\tau + d}\right) = (c\tau + d)^2 E_2^{(N)}(\tau) + \frac{6c(c\tau + d)}{\pi i [SL_2(\mathbb{Z}) : \Gamma_0(N)]}.$$

**3. Transformation formula of the Eisenstein series of weight 2 for  $\Gamma_0(N)$  at  $i\infty$**

In this section, we study the Eisenstein series of weight  $k \geq 2$  for  $\Gamma_0(N)$  at  $i\infty$  which is necessary for the definition and study of the Atkin inner product for  $\Gamma_0(N)$  at  $i\infty$ .

The series  $E_k^{(N)}$  is a modular form of weight  $k$  for  $\Gamma_0(N)$ . We define another series  $G_k^{(N)}$  by

$$(3) \quad G_k^{(N)}(\tau) = \sum_{\substack{c,d \in \mathbb{Z} \\ (d,N)=1}} \frac{1}{(cN\tau + d)^k}.$$

Because  $k \geq 3$ , the series  $G_k^{(N)}$  converges absolutely and uniformly on any compact subsets of  $\mathfrak{H}$  and we have

$$\begin{aligned} \sum_{\substack{c,d \in \mathbb{Z} \\ (d,N)=1}} \frac{1}{(cN\tau + d)^k} &= \left( \sum_{\substack{n=1 \\ (n,N)=1}}^{\infty} \frac{1}{n^k} \right) \sum_{(cN,d)=1} \frac{1}{(cN\tau + d)^k} \\ &= \prod_{\substack{p|N \\ p:\text{prime}}} \left( 1 - \frac{1}{p^k} \right) \zeta(k) \sum_{(cN,d)=1} \frac{1}{(cN\tau + d)^k}, \end{aligned}$$

where  $\zeta$  is the Riemann zeta function. Hence we get

$$(4) \quad G_k^{(N)}(\tau) = 2 \prod_{p|N} \left( 1 - \frac{1}{p^k} \right) \zeta(k) E_k^{(N)}(\tau).$$

We also call this  $G_k^{(N)}$  the Eisenstein series of weight  $k$  for  $\Gamma_0(N)$  at  $i\infty$ .

Since  $\begin{pmatrix} 1 & 1 \\ 0 & 1 \end{pmatrix} \in \Gamma_0(N)$ , the  $E_k^{(N)}$  is periodic with period 1 and has a Fourier expansion. We now compute an explicit Fourier expansion for  $E_k^{(N)}$  in the following.

**Proposition 3.1.** *Let  $k$  be an even integer greater than 2,  $p$  be a prime number, and  $\tau \in \mathfrak{H}$ . Then the Eisenstein series of weight  $k$  for  $\Gamma_0(N)$  at  $i\infty$  has the following  $q$ -expansion.*

$$(5) \quad E_k^{(N)}(\tau) = \prod_{\substack{p|N \\ p:\text{prime}}} \frac{p^k}{p^k - 1} \sum_{d|N} \frac{\mu(d)}{d^k} \left( 1 - \frac{2k}{B_k} \sum_{m=1}^{\infty} \sigma_{k-1}(m) q^{\frac{N}{d}m} \right),$$

where  $\mu$  is the Möbius function,  $B_k$  is the Bernoulli number and  $\sigma_k$  is the power-sum of divisors:

$$\begin{aligned} \frac{x}{e^x - 1} &= \sum_{k=0}^{\infty} B_k \frac{x^k}{k!}, \\ \sigma_k(n) &= \sum_{d|n} d^k. \end{aligned}$$

*Proof.* By the equality (4),

$$\begin{aligned}
 (6) \quad E_k^{(N)}(\tau) &= \frac{1}{2\zeta(k)} \prod_{p|N} \frac{p^k}{p^k - 1} G_k^{(N)}(\tau) \\
 (7) \quad &= \frac{1}{2\zeta(k)} \prod_{p|N} \frac{p^k}{p^k - 1} \sum_{d|N} \mu(d) \sum' \frac{1}{(mN\tau + dn)^k} \\
 (8) \quad &= \frac{1}{2\zeta(k)} \prod_{p|N} \frac{p^k}{p^k - 1} \sum_{d|N} \frac{\mu(d)}{d^k} G_k\left(\frac{N}{d}\tau\right).
 \end{aligned}$$

Here  $G_k$  is the Eisenstein series of weight  $k$  for  $SL_2(\mathbb{Z})$ . It is well known that the Eisenstein series  $G_k$  has a  $q$ -expansion,

$$G_k(\tau) = 2\zeta(k) + 2 \frac{(2i\pi)^k}{(k-1)!} \sum_{m=1}^{\infty} \sigma_{k-1}(m) q^m.$$

Substituting this to (8), we complete the proof. □

When  $k = 2$ , the series (2) and (3) are not absolutely convergent. However, if we specify the order of summation of (3) as

$$(9) \quad 2 \prod_{\substack{p|N \\ p:\text{prime}}} \left(1 - \frac{1}{p^2}\right) \zeta(2) + 2 \sum_{c \geq 1} \sum_{\substack{d \in \mathbb{Z} \\ (d,N)=1}} \frac{1}{(cN\tau + d)^2},$$

then this series defines a holomorphic function on  $\mathfrak{H}$ . Moreover, because the series

$$(10) \quad 1 - 24 \sum_{m=1}^{\infty} \sigma_1(m) q^m$$

is absolutely convergent for  $|q| < 1$ , we find that the series (5) defines a holomorphic function on  $\mathfrak{H}$  for  $k = 2$  ( $B_2 = \frac{1}{6}$ ). We adopt this series to define the Eisenstein series of weight 2 for  $\Gamma_0(N)$  at  $i\infty$ , and write it as  $E_2^{(N)}$ . This is the definition which we introduced in Section 2. At this point, we do not know whether the right hand side of (4) equals (9) when  $k = 2$ , because the sum in (4) is not absolutely convergent.

It is easy to see that the functions  $E_2^{(N)}$  and  $G_2^{(N)}$  are periodic of period 1, and  $E_2^{(N)}$  is holomorphic at infinity. These functions are not modular for  $\Gamma_0(N)$  but “nearly” modular. Now, we introduce a new function  $G_k^{(N)*}$  to show the nearly modular property of these functions.

Let  $p$  be a prime number and  $\tau \in \mathfrak{H}$ , we now define

$$G_2^{(N)*}(\tau) = G_2^{(N)}(\tau) - \frac{\pi}{\Im(\tau)N} \prod_{p|N} \left(1 - \frac{1}{p}\right).$$

This function is not holomorphic on  $\mathfrak{H}$ , but we can show that it is modular of weight 2.

**Theorem 3.1.** For  $\gamma \in \Gamma_0(N)$  and  $\tau \in \mathfrak{H}$ ,

$$(11) \quad G_2^{(N)*}(\gamma\tau) = (c\tau + d)^2 G_k^{(N)*}(\tau), \quad \gamma = \begin{pmatrix} a & b \\ c & d \end{pmatrix}.$$

i.e.  $G_2^{(N)*}$  is a nonholomorphic modular form of weight 2 for  $\Gamma_0(N)$ .

*Proof.* The series

$$(12) \quad \Phi^{(N)}(\tau, s) = \sum_{\substack{c, d \in \mathbb{Z} \\ (d, N)=1}} \frac{1}{(cN\tau + d)^2 |cN\tau + d|^s}, \quad \Re(s) > 0$$

converges absolutely and uniformly in  $s$  for  $\Re(s) \geq \varepsilon > 0$  and for fixed  $\tau$  with  $\Im(\tau) > 0$ . Hence for fixed  $\tau$ ,  $\Phi^{(N)}(\tau, s)$  is holomorphic in  $s$  for  $\Re(s) > 0$ . We write

$$\begin{aligned} \Phi^{(N)}(\tau, s) &= \sum_{\substack{c, d \in \mathbb{Z} \\ (d, N)=1}} \frac{1}{(cN\tau + d)^2 |cN\tau + d|^s} \\ &= \sum_{h|N} \frac{\mu(h)}{h^{2+s}} \sum' \frac{1}{(c\frac{N}{h}\tau + d)^2 |c\frac{N}{h}\tau + d|^s} \\ &= \sum_{h|N} \frac{\mu(h)}{h^{2+s}} \Phi\left(\frac{N}{h}\tau, s\right), \end{aligned}$$

where  $\mu$  is the Möbius function and  $\Phi(\tau, s) = \Phi^{(1)}(\tau, s)$ . By Hecke [2],  $\Phi(\tau, s)$  continues holomorphically to a neighborhood of  $s = 0$  for  $\Im(\tau) > 0$ . We define  $G_2^*(\tau)$  as the value of  $\Phi(\tau, s)$  at  $s = 0$ :

$$G_2^*(\tau) := \Phi(\tau, 0).$$

It is well known that  $G_2^*(\tau) = G_2^{(1)*}(\tau)$ . Therefore, we get

$$\begin{aligned} \Phi^{(N)}(\tau, 0) &= \sum_{h|N} \frac{\mu(h)}{h^2} G_2^*\left(\frac{N}{h}\tau\right) \\ &= \sum_{h|N} \frac{\mu(h)}{h^2} \left( G_2\left(\frac{N}{h}\tau\right) - \frac{h\pi}{N\Im(\tau)} \right) \\ &= \sum_{h|N} \frac{\mu(h)}{h^2} G_2\left(\frac{N}{h}\tau\right) - \frac{\pi}{\Im(\tau)N} \prod_{\substack{p|N \\ p:\text{prime}}} \left(1 - \frac{1}{p}\right) \end{aligned}$$

$$\begin{aligned}
&= \sum_{h|N} \frac{\mu(h)}{h^2} \left( 2\zeta(2) - 8\pi^2 \sum_{m \geq 1} \left( \sum_{d|m} d \right) e^{2\pi i \frac{N}{h} m \tau} \right) \\
&\quad - \frac{\pi}{\Im(\tau)N} \prod_{\substack{p|N \\ p:\text{prime}}} \left( 1 - \frac{1}{p} \right) \\
&= 2 \prod_{\substack{p|N \\ p:\text{prime}}} \left( 1 - \frac{1}{p} \right) \zeta(2) - 8\pi^2 \sum_{h|N} \frac{\mu(h)}{h^2} \sum_{c \geq 1} \sum_{d \geq 1} d e^{2\pi i c \frac{N}{h} d \tau} \\
&\quad - \frac{\pi}{\Im(\tau)N} \prod_{\substack{p|N \\ p:\text{prime}}} \left( 1 - \frac{1}{p} \right) \\
&= 2 \prod_{\substack{p|N \\ p:\text{prime}}} \left( 1 - \frac{1}{p} \right) \zeta(2) + 2 \sum_{c \geq 1} \sum_{h|N} \frac{\mu(h)}{h^2} \sum_{d \in \mathbb{Z}} \frac{1}{(c \frac{N}{h} \tau + d)^2} \\
&\quad - \frac{\pi}{\Im(\tau)N} \prod_{\substack{p|N \\ p:\text{prime}}} \left( 1 - \frac{1}{p} \right) \\
&= 2 \prod_{\substack{p|N \\ p:\text{prime}}} \left( 1 - \frac{1}{p} \right) \zeta(2) + 2 \sum_{c \geq 1} \sum_{\substack{d \in \mathbb{Z} \\ (d, N) = 1}} \frac{1}{(cN\tau + d)^2} \\
&\quad - \frac{\pi}{\Im(\tau)N} \prod_{\substack{p|N \\ p:\text{prime}}} \left( 1 - \frac{1}{p} \right) \\
&= G_2^{(N)*}(\tau).
\end{aligned}$$

Here we have used the following formula which is valid for  $k \geq 2$ .

$$\sum_{m \in \mathbb{Z}} \frac{1}{(m + \tau)^k} = \frac{(-2\pi i)^k}{(k-1)!} \sum_{n \geq 1} n^{k-1} e^{2\pi i n \tau}.$$

Since for  $\gamma = \begin{pmatrix} a & b \\ c & d \end{pmatrix} \in \Gamma_0(N)$ ,

$$\Phi^{(N)}(\gamma\tau, s) = \Phi^{(N)}(\tau, s)(c\tau + d)^2 |c\tau + d|^s,$$

we get

$$G_2^{(N)*}(\gamma\tau) = (c\tau + d)^2 G_2^{(N)*}(\tau),$$

and we complete our proof of the theorem.  $\square$

Using the equation (11), we can calculate the transformation formula of  $G_2^{(N)}(\tau)$ .



**Corollary 3.1.1.** Let  $\gamma = \begin{pmatrix} a & b \\ c & d \end{pmatrix} \in \Gamma_0(N)$  and  $\tau \in \mathfrak{H}$ . Then we have

$$(13) \quad G_2^{(N)}(\gamma\tau) = (c\tau + d)^2 G_2^{(N)}(\tau) - \frac{2\pi i}{N} \prod_{\substack{p|N \\ p:\text{prime}}} \left(1 - \frac{1}{p}\right) c(c\tau + d).$$

*Proof.* For  $\gamma = \begin{pmatrix} a & b \\ c & d \end{pmatrix} \in \Gamma_0(N)$ , we have

$$\begin{aligned} G_2^{(N)}(\gamma\tau) &= G_2^{(N)*}(\gamma\tau) + \frac{\pi}{\Im(\gamma\tau)N} \prod_{p|N} \left(1 - \frac{1}{p}\right) \\ &= (c\tau + d)^2 G_2^{(N)*}(\tau) + 2\pi i \frac{|c\tau + d|^2}{\tau - \bar{\tau}} \frac{1}{N} \prod_{p|N} \left(1 - \frac{1}{p}\right) \\ &= (c\tau + d)^2 G_2^{(N)*}(\tau) + 2\pi i \left(\frac{(c\tau + d)^2}{\tau - \bar{\tau}} - c(c\tau + d)\right) \frac{1}{N} \prod_{p|N} \left(1 - \frac{1}{p}\right) \\ &= (c\tau + d)^2 G_2^{(N)}(\tau) - \frac{2\pi i}{N} \prod_{p|N} \left(1 - \frac{1}{p}\right) c(c\tau + d). \end{aligned}$$

The proof is completed. □

Moreover, in the course of our proof of Theorem 3.1, it is shown that the equality (4) also holds for  $k = 2$ .

**Corollary 3.1.2.** We have

$$G_2^{(N)}(\tau) = \frac{\pi^2}{3} \prod_{\substack{p|N \\ p:\text{prime}}} \left(1 - \frac{1}{p^2}\right) E_2^{(N)}(\tau).$$

Moreover, for  $\gamma = \begin{pmatrix} a & b \\ c & d \end{pmatrix} \in \Gamma_0(N)$ ,

$$(14) \quad E_2^{(N)}(\gamma\tau) = (c\tau + d)^2 E_2^{(N)}(\tau) + \frac{6c(c\tau + d)}{\pi i [SL_2(\mathbb{Z}) : \Gamma_0(N)]}.$$

*Proof.* It follows from  $\zeta(2) = \frac{\pi^2}{6}$  and

$$[SL_2(\mathbb{Z}) : \Gamma_0(N)] = N \prod_{p|N} \left(1 + \frac{1}{p}\right). \quad \square$$

From the “nearly modular” property of  $E_2^{(N)}$ , we can construct a new modular form of weight  $k + 2$  for  $\Gamma_0(N)$  from a modular form of weight  $k$  for  $\Gamma_0(N)$  in the following way.

**Corollary 3.1.3.** *Let  $f(\tau)$  be a modular form of weight  $k$  for  $\Gamma_0(N)$ . Then*

$$(15) \quad \frac{df}{d\tau}(\tau) - \frac{k\pi i[SL_2(\mathbb{Z}) : \Gamma_0(N)]}{6} E_2^{(N)}(\tau)f(\tau)$$

*is a modular form of weight  $k + 2$  for  $\Gamma_0(N)$ . Moreover,*

$$(16) \quad \frac{dE_2^{(N)}}{d\tau}(\tau) - \frac{\pi i[SL_2(\mathbb{Z}) : \Gamma_0(N)]}{6} E_2^{(N)}(\tau)^2$$

*is a modular form of weight 4 for  $\Gamma_0(N)$ .*

*Proof.* The modular property of weight  $k + 2$  can be checked directly from the equation (14). For relatively prime integers  $a, c$ , if  $\frac{a}{c}$  is not  $\Gamma_0(N)$ -equivalent to  $i\infty$ , then

$$\lim_{\tau \rightarrow i\infty} \frac{1}{(c\tau + d)^2} E_2^{(N)}\left(\frac{a\tau + b}{c\tau + d}\right) = 0$$

for  $\begin{pmatrix} a & b \\ c & d \end{pmatrix} \in SL_2(\mathbb{Z})$  (We will prove this fact in Section 4), this fact shows that the functions of (15) and (16) are holomorphic at cusps for  $\Gamma_0(N)$ .  $\square$

**Example.** Since the dimension of the space of modular forms of weight  $k$  for  $\Gamma_0(N)$  is finite, we can prove the equality between two modular forms by chekin agreement of sufficiently many their coefficients of the Fourier expansions. For example, we have the following equalities:

$$\begin{aligned} \frac{1}{2^\nu \pi i} \frac{dE_4^{(2^\nu)}}{d\tau}(\tau) - E_2^{(2^\nu)}(\tau)E_4^{(2^\nu)}(\tau) &= -E_6^{(2^\nu)}(\tau), \\ \frac{1}{2^{\nu-2} \pi i} \frac{dE_2^{(2^\nu)}}{d\tau}(\tau) - E_2^{(2^\nu)}(\tau)^2 &= -E_4^{(2^\nu)}(\tau), \\ \frac{3}{2\pi i} \frac{dE_2^{(3)}}{d\tau}(\tau) - E_2^{(3)}(\tau)^2 &= -E_4^{(3)}(\tau), \end{aligned}$$

where  $\nu$  is an arbitrary positive integer.

#### 4. Self-adjointness of the Hecke operators

In this section, we prove Theorem 1. First, we review the Hecke operator for  $\Gamma_0(N)$ . For simplicity, we give the definition of the Hecke operator for  $m \in \mathbb{N}$  which is relatively prime to  $N$ . Let  $\mathcal{M}_k^{(N)}$  be the set of modular functions of weight  $k$  for  $\Gamma_0(N)$  which are holomorphic on  $\mathfrak{H}$  and at all cusps except for  $i\infty$ , and write  $\mathcal{M}^{(N)} = \mathcal{M}_0^{(N)}$ .

Let  $k \in \mathbb{Z}$  and  $m$  be an integer relatively prime to  $N$ . For  $f \in \mathcal{M}_k^{(N)}$ , we define the action of the Hecke operator  $T_n$  by

$$(f|_k T_m)(\tau) = m^{\frac{k}{2}} \sum_{\gamma \in \Gamma_0(N) \backslash M_m} \frac{1}{(c\tau + d)^k} f\left(\frac{a\tau + b}{c\tau + d}\right), \quad \gamma = \begin{pmatrix} a & b \\ c & d \end{pmatrix},$$

where

$$M_m = \left\{ \begin{pmatrix} a & b \\ c & d \end{pmatrix} \in GL_2(\mathbb{Z}) \mid \det \begin{pmatrix} a & b \\ c & d \end{pmatrix} = m \right\}.$$

This definition is from Kaneko-Zagier [5, p110]

If  $f$  does not have modularity, the value  $\frac{1}{(c\tau+d)^k} f\left(\frac{a\tau+b}{c\tau+d}\right)$  depends on the choice of a coset representative. So this definition is well-defined only for  $f \in \mathcal{M}_k^{(N)}$ . However the following definition works for any 1-periodic function.

Let  $k \in \mathbb{Z}$  and  $m$  be a relatively prime integer for  $N$ . For a 1-periodic function  $f$ , we define “the Hecke operator at  $\infty$ ”  $T_k^\infty$  by

$$(f|_k T_m^\infty)(\tau) = m^{\frac{k}{2}} \sum_{\substack{ad=m \\ a,d>0}} \sum_{b \pmod{d}} d^{-k} f\left(\frac{a\tau+b}{d}\right).$$

Because the set of matrices  $\begin{pmatrix} a & b \\ 0 & d \end{pmatrix}$  with  $ad = m$  and  $0 \leq b < d = \frac{m}{a}$  forms a complete set of coset representatives for  $\Gamma_0(N) \backslash M_m$ , both  $f|_k T_m$  and  $f|_k T_m^\infty$  coincide for  $f \in \mathcal{M}_k^{(N)}$ . We now start a proof of Theorem 1.

*Proof.* We claim that

$$(17) \quad \text{Res}_\infty((f|_k T_m^\infty) \cdot h) = \text{Res}_\infty(f \cdot (h|_{2-k} T_m^\infty))$$

for Laurent serieses  $f, h$  in  $q$  and

$$(18) \quad (gE_2^{(N)})|_2 T_m^\infty \equiv (g|_0 T_m) \cdot E_2^{(N)} \pmod{\mathcal{M}_2^{(N)}} \quad (g \in \mathcal{M}^{(N)}),$$

where  $\text{Res}_\infty(F)$  for a 1-periodic holomorphic function  $F$  on  $\mathfrak{H}$  denotes the residue at infinity of  $2\pi i F(\tau) d\tau$ , i.e. the constant term of  $F$  as Laurent series in  $q$ . Theorem 1 then follows from (17) and (18) using the fact that  $\mathcal{M}^{(N)} \mathcal{M}_2^{(N)} \subset \mathcal{M}_2^{(N)}$  and that  $\text{Res}_\infty$  vanishes on  $\mathcal{M}_2^{(N)}$ :

$$(19) \quad (f|_0 T_m, g) = \text{Res}_\infty((f|_0 T_m) \cdot g \cdot E_2^{(N)})$$

$$(20) \quad = \text{Res}_\infty(f \cdot (gE_2^{(N)})|_2 T_m^\infty)$$

$$(21) \quad = \text{Res}_\infty(f \cdot (g|_0 T_m) \cdot E_2^{(N)}) = (f, g|_0 T_m) \quad (f, g \in \mathcal{M}^{(N)}).$$

We prove the equation (17). Let  $f(\tau) = \sum_r A_r q^r$  ( $q = e^{2\pi i \tau}$ ). Then,

$$\begin{aligned} (f|_k T_m^\infty)(\tau) &= m^{\frac{k}{2}} \sum_{\substack{ad=m \\ a,d>0}} \sum_{b \pmod{d}} d^{-k} f\left(\frac{a\tau+b}{d}\right) \\ &= m^{\frac{k}{2}} \sum_r \sum_{\substack{ad=m \\ a,d>0}} \frac{A_r}{d^k} e^{2\pi i r \frac{a}{d} \tau} \sum_{b \pmod{d}} e^{2\pi i r \frac{b}{d}} \\ &= m^{\frac{k}{2}} \sum_{\substack{ad=m \\ a,d>0}} d^{1-k} \sum_r A_r d q^{ar}. \end{aligned}$$

If we put  $h(\tau) = \sum_s B_s q^s$  ( $q = e^{2\pi i\tau}$ ),

$$\begin{aligned} ((f|_k T_m^\infty)(\tau))h(\tau) &= m^{\frac{k}{2}} \sum_{\substack{ad=m \\ a,d>0}} d^{1-k} \sum_r \sum_s A_{rd} B_s q^{ar+s} \\ &= m^{\frac{k}{2}} \sum_n \sum_{\substack{ad=m \\ a,d>0}} d^{1-k} \sum_r A_{rd} B_{n-ar} q^n. \end{aligned}$$

Hence,

$$\begin{aligned} \text{Res}_\infty((f|_k T_m^\infty) \cdot h) &= m^{\frac{k}{2}} \sum_{\substack{ad=m \\ a,d>0}} d^{1-k} \sum_r A_{dr} B_{-ar} \\ &= m^{1-\frac{k}{2}} \sum_{\substack{ad=m \\ a,d>0}} a^{k-1} \sum_s B_{as} A_{-ds} \\ &= \text{Res}_\infty(f \cdot (g|_{2-k} T_m^\infty)). \end{aligned}$$

For (18), we use the transformation formula of  $E_2^{(N)}(\tau)$ . If we put

$$E_2^{(N)}(\tau) = E_2^{(N)*}(\tau) + \frac{3}{\pi \Im(\tau) [SL_2(\mathbb{Z}) : \Gamma_0(N)]},$$

then the non-holomorphic function  $E_2^{(N)*}$  transforms like a modular form of weight 2 for  $\Gamma_0(N)$ . Denoting by  $\mathcal{M}_2^{(N)*}$  the space of functions with the last property, and observing that  $\mathcal{M}^{(N)} \mathcal{M}_2^{(N)*} \subseteq \mathcal{M}_2^{(N)*}$  and that  $|_2 T_m$  preserves  $\mathcal{M}_2^{(N)*}$ , we have

$$\begin{aligned} (gE_2^{(N)})|_2 T_m^\infty - (g|_0 T_m)E_2^{(N)} &= (gE_2^{(N)*})|_2 T_m^\infty - (g|_0 T_m)E_2^{(N)*} \\ &\quad + \frac{3}{\pi [SL_2(\mathbb{Z}) : \Gamma_0(N)]} \left\{ \left( \frac{g}{\Im(\tau)} \right) \Big|_2 T_m^\infty - \frac{g|_0 T_m}{\Im(\tau)} \right\} \\ &\equiv \frac{3}{\pi [SL_2(\mathbb{Z}) : \Gamma_0(N)]} \left\{ \left( \frac{g}{\Im(\tau)} \right) \Big|_2 T_m^\infty - \frac{g|_0 T_m}{\Im(\tau)} \right\} \pmod{\mathcal{M}_2^{(N)*}}. \end{aligned}$$

The right-hand side of this formula vanishes by the following calculation.

$$(22) \quad \left( \left( \frac{g}{\Im(\tau)} \right) \Big|_2 T_m^\infty \right) (\tau) = m \sum_{\substack{ad=m \\ a,d>0}} \sum_{b \pmod{d}} \frac{1}{d^2} g \left( \frac{a\tau + b}{d} \right) \Im \left( \frac{a\tau + b}{d} \right)^{-1}$$

$$(23) \quad = \frac{(g|_0 T_m)(\tau)}{\Im(\tau)}.$$

So the left-hand side, which is holomorphic, belongs to  $\mathcal{M}_2^{(N)}$  as claimed.  $\square$

**Remark.** 1) The Hecke operator for  $\Gamma_0(N)$  can be defined for any integer  $m$ . But for  $m$  which is not relatively prime to  $N$ , the Atkin inner product for  $\Gamma_0(N)$  does not have the self-adjointness of the Hecke operator  $T_m$ .  
 2) As we remarked earlier, the self-adjointness of the Hecke operators does not uniquely determine the inner product. If we replace  $E_2^{(N)}$  with  $E_2^{(N)} + f$  for any  $f \in \mathcal{M}_2^{(N)}$ , the self-adjointness still holds true. (The proof is similar.)

**5. Relation with the Petersson type inner product**

In this section, we give a proof of Theorem 2. We first study fundamentals domain of  $\Gamma_0(N)$ .

**Lemma 5.0.1.** *Let*

$$\Gamma_\infty = \{\sigma_0^n | n \in \mathbb{Z}\}, \quad \sigma_0 = \begin{pmatrix} 1 & 1 \\ 0 & 1 \end{pmatrix},$$

and

$$C_\sigma = \{\tau \in \mathfrak{H} \mid |c\tau + d| \geq 1\} \quad \text{for } \sigma = \begin{pmatrix} a & b \\ c & d \end{pmatrix} \in \Gamma_0(N).$$

Then the region

$$\mathcal{F} = \left\{ \bigcap_{\sigma \in \Gamma_0(N) - \Gamma_\infty} C_\sigma \right\} \cap \left\{ \tau \in \mathfrak{H} \mid |\Re(\tau)| \leq \frac{1}{2} \right\}$$

is a fundamental domain of  $\Gamma_0(N)$ .

*Proof.* See [4, p. 39 Theorem 3]. □

**Corollary 5.0.4.** *There exists a fundamental domain  $\mathcal{F}$  of  $\Gamma_0(N)$  which is symmetrical with respect to the imaginary axis and  $\mathcal{F} \subseteq \{\tau \in \mathfrak{H} \mid |\Re(\tau)| \leq 1/2\}$ .*

*Proof.*  $\mathcal{F}$  in Lemma 5.0.1 is the required domain. In fact, if  $\sigma = \begin{pmatrix} a & b \\ c & d \end{pmatrix} \in \Gamma_0(N)$ , then  $\sigma' = \begin{pmatrix} a & -b \\ -c & d \end{pmatrix} \in \Gamma_0(N)$  and the regions  $C_\sigma$  and  $C_{\sigma'}$  are symmetric with respect to imaginary axis. □

Let  $\mathcal{F}$  be the special fundamental domain given in Lemma 5.0.1 and  $\Omega$  the subdomain of  $\mathcal{F}$  which we get by cutting down from  $\mathcal{F}$  neighborhoods of cusps bounded by the line parallel to the real axis and the small circles with center at each finite cusp. For  $f \in \mathcal{M}^{(N)}$ , we calculate

$$\int_{\partial\Omega} f \cdot E_2^{(N)*} d\tau,$$

where  $\partial\Omega$  is the boundary of  $\Omega$ , and  $E_2^{(N)*}$  is the nonholomorphic Eisenstein series of weight 2 for  $\Gamma_0(N)$  at  $i\infty$  which was defined in Section 2. By the Stokes theorem,

$$\begin{aligned} \int_{\partial\Omega} f \cdot E_2^{(N)*} d\tau &= \int_{\Omega} \partial \left( f \cdot E_2^{(N)*} d\tau \right) \\ &= - \int_{\Omega} \frac{d}{d\bar{\tau}} \left( f \cdot E_2^{(N)*} \right) d\tau d\bar{\tau}. \end{aligned}$$

We apply the following equation to the above.

$$\frac{(4\pi\Im(\tau))^2}{2\pi i} \frac{d}{d\bar{\tau}} \left( f \cdot E_2^{(N)*} \right) (\tau) = \frac{12}{[SL_2(\mathbb{Z}) : \Gamma_0(N)]} f(\tau).$$

Then we get,

$$\int_{\partial\Omega} f \cdot E_2^{(N)*} d\tau = \frac{-3}{\pi[SL_2(\mathbb{Z}) : \Gamma_0(N)]} \int_{\Omega} f(\tau) \cdot \frac{dx dy}{y^2} \quad (\tau = x + iy).$$

Because

$$\text{vol}(\Gamma_0(N)\backslash\mathfrak{H}) = \frac{\pi}{3} \cdot [SL_2(\mathbb{Z}) : \Gamma_0(N)],$$

we must show

$$\begin{aligned} \lim_{\Omega \rightarrow \mathcal{F}} \int_{\partial\Omega} f \cdot E_2^{(N)*} d\tau &= -(f, 1)_{(N)} \\ &= -\text{constant term of } fE_2^{(N)} \text{ as Laurent series in } q \\ &= -\text{Res} \left( f(q)E_2^{(N)}(q) \frac{dq}{q}, q = 0 \right), \quad q = e^{2\pi i\tau}. \end{aligned}$$

To calculate the above integral, we mark the boundary of  $\Omega$  in the following way.  $L, L_0$  and  $L_1$  are straight lines on  $\Im(\tau) = Y \gg 0, \Re(\tau) = \frac{1}{2}$  and  $\Re(\tau) = -\frac{1}{2}$  respectively. The points at which the fundamental domain  $\mathcal{F}$  touches the real axis are labelled from left to right by  $c_1, c_2, \dots, c_\mu$  and the chords on the circle with center  $c_i (i = 1, 2, \dots, \mu)$  are labelled  $l_1, l_2, \dots, l_\mu$  respectively. The rest of the boundary  $\Omega$  is denoted by  $C$ . (See Figure 3)

Here, we study the way of pasting the edges of the fundamental domain  $\mathcal{F}$ . This comes from next lemma.

**Lemma 5.0.2** (Poincaré [3]). *Let  $\mathcal{F}$  be a fundamental domain of  $\Gamma_0(N)$ , then the boundary  $\mathcal{F}$  divides two parts which are congruent about  $\Gamma_0(N)$ . That is, we can divide the boundary of  $\mathcal{F}$  into sub-boundaries  $\lambda_1, \lambda_2, \dots, \lambda_k$  and  $\mu_1, \mu_2, \dots, \mu_k$  which satisfies  $\mu_j = \sigma_j(\lambda_j), \sigma_j \in \Gamma_0(N) (j = 1, 2, \dots, k)$ .*

By the above lemma, we can divide the boundary  $\mathcal{F}$  into two parts which are equivalent for some  $\sigma \in \Gamma_0(N)$ . The straight lines on  $\Re(\tau) = \frac{1}{2}$  and  $\Re(\tau) = -\frac{1}{2}$  are equivalent by  $\begin{pmatrix} 1 & 1 \\ 0 & 1 \end{pmatrix} \in \Gamma_0(N)$ . Because  $\Im(\sigma(\tau)) > 0$

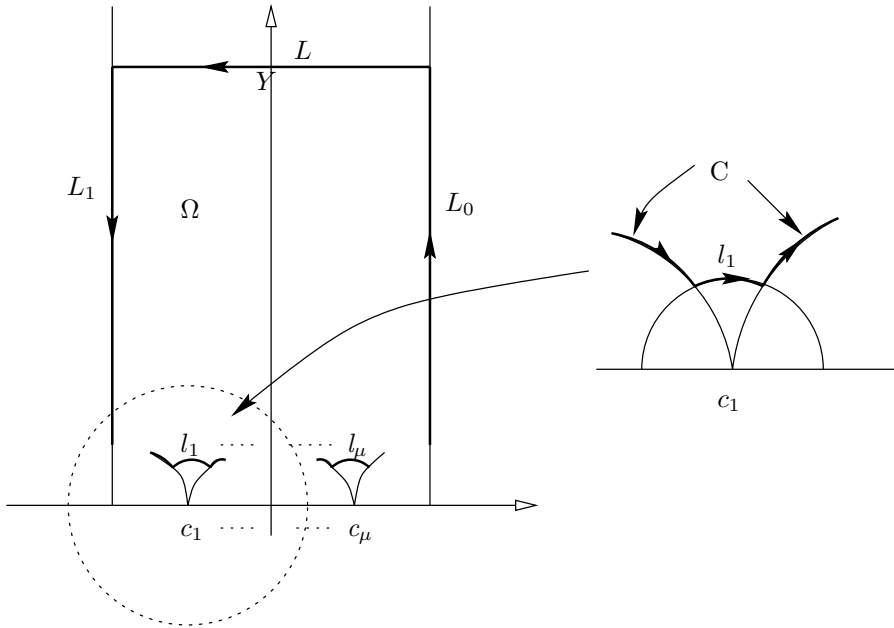

Figure 3: Boundary  $\Omega$

for  $\sigma \in \Gamma_0(N)$  and  $\tau \in \mathfrak{H}$ , the chords touching real axis are equivalent in themselves. For all  $c_i$ , ( $i = 1, 2, \dots, l$ ), there exist two chords of touching  $c_i$ , then there exist  $\sigma, \sigma' \in \Gamma_0(N)$  which paste the chords touching  $c_i$  onto the chords touching  $c_j$ . If  $c_i = c_j$ , then  $\sigma' = \sigma^{-1}$ . Since the fractional linear transformation transforms a circle to a circle,  $\sigma$  transforms a small circle with the center  $c_i$  to a small circle with the center  $c_j$ . (See Figure 4)

Because  $fE_2^{(N)*} d\tau$  is invariant for  $\sigma \in \Gamma_0(N)$  and  $L_0, L_1$ , and the edges in  $C$  are pasted by some  $\sigma \in \Gamma_0(N)$ , we have

$$\int_{L_0} fE_2^{(N)*} d\tau + \int_{L_1} = \int_C fE_2^{(N)*} d\tau = 0.$$

Hence we get

$$(24) \quad \int_{\partial\Omega} f \cdot E_2^{(N)*} d\tau = \int_L fE_2^{(N)*} d\tau + \int_{l_1} + \int_{l_2} + \dots + \int_{l_\mu}.$$

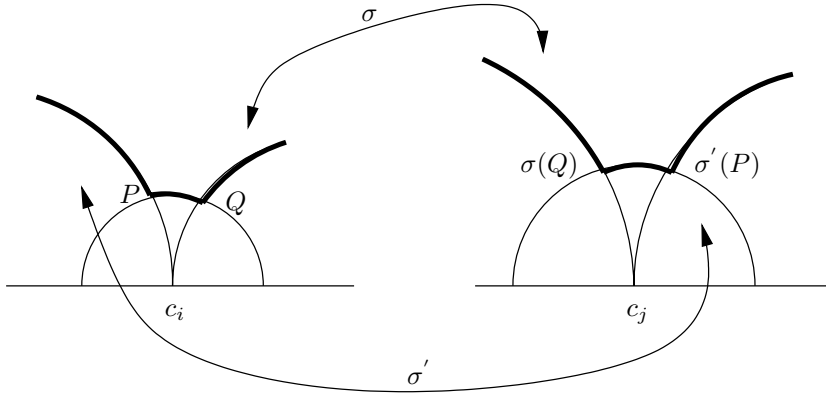

Figure 4: Neighborhood of cusp

We calculate the first term of the right side of the above equation,

$$\begin{aligned} & \int_L f E_2^{(N)*}(\tau) d\tau \\ &= \int_L f(\tau) \cdot \left( E_2^{(N)}(\tau) - \frac{3}{\pi \Im(\tau) [SL_2(\mathbb{Z}) : \Gamma_0(N)]} \right) d\tau \\ &= \int_L f E_2^{(N)}(\tau) d\tau - \frac{3}{\pi [SL_2(\mathbb{Z}) : \Gamma_0(N)]} \int_L \frac{f(\tau)}{\Im(\tau)} d\tau, \quad q = e^{2\pi i \tau}. \end{aligned}$$

For the first term of the above equation, we change the variable  $\tau$  to  $q = e^{2\pi i \tau}$ , and we get

$$\lim_{y \rightarrow \infty} \int_L f E_2^{(N)}(\tau) d\tau = -\text{Res} \left( f(q) E_2^{(N)}(q) \frac{dq}{q}, q = 0 \right).$$

For the integral of the second term, we have

$$\int_L \frac{f(\tau)}{\Im(\tau)} d\tau = \frac{1}{Y} \int_{\frac{1}{2}}^{-\frac{1}{2}} f(x + iY) dx \rightarrow 0 \quad \text{as } Y \rightarrow \infty.$$

Hence, if we show

$$\lim \int_{l_i} f E_2^{(N)*} d\tau = 0,$$

then, by the equation (24), we complete the proof. Here the limit means that the radius of circle  $l_i$  tends to 0.

Because all cusps except for  $i\infty$  belong to  $\mathbb{Q}$ , we can put  $c_i = \frac{a}{c}$ , ( $a, c \in \mathbb{Z}$  and  $(a, c) = 1$ ). Then there exists  $\sigma = \begin{pmatrix} a & b \\ c & d \end{pmatrix} \in SL_2(\mathbb{Z})$ . The map  $\sigma$



transforms  $i\infty$  to  $c_i$ . Let  $w = \sigma^{-1}(\tau)$ , then,

$$\begin{aligned} \int_{l_i} f(\tau) E_2^{(N)*}(\tau) d\tau &= \int_{\sigma^{-1}(l_i)} f\left(\frac{aw+b}{cw+d}\right) E_2^{(N)*}\left(\frac{aw+b}{cw+d}\right) d\left(\frac{aw+b}{cw+d}\right) \\ &= \int_{\sigma^{-1}(l_i)} f\left(\frac{aw+b}{cw+d}\right) E_2^{(N)}\left(\frac{aw+b}{cw+d}\right) \frac{dw}{(cw+d)^2} \\ &\quad + \int_{\sigma^{-1}(l_i)} \frac{6if\left(\frac{aw+b}{cw+d}\right)}{\pi[SL_2(\mathbb{Z}) : \Gamma_0(N)](w-\bar{w})} \frac{|cw+d|^2}{(cw+d)^2} dw. \end{aligned}$$

If  $l_i$  places on the circle with the center  $\frac{a}{c}$  and radius  $r$ , then  $\sigma^{-1}(l_i)$  places on the circle with the center  $-\frac{d}{c}$  and radius  $\frac{1}{rc^2}$ , and if the direction  $l_i$  is positive, then the direction  $\sigma^{-1}(l_i)$  is negative. (See Figure 5)

Here we put the two chords  $C_{i_1}, C_{i_2}$  which belong in the boundary of  $\mathcal{F}$  and touch  $c_i = \frac{a}{c}$ .  $A$  is the intersection point of  $C_{i_1}$  and  $l_i$  and  $B$  is the intersection point of  $C_{i_2}$  and  $l_i$ . Moreover,  $r_1$  is the radius of  $C_{i_1}$  and  $r_2$  is the radius of  $C_{i_2}$ , and the centers of  $C_{i_1}$  and  $C_{i_2}$  are  $\frac{a}{c} - r_1$  and  $\frac{a}{c} + r_2$  respectively. (See Figure 5) Then, we can representate

$$\begin{aligned} A &= \frac{a}{c} - \frac{r^2}{2r_1} + i\sqrt{r^2 - \frac{r^4}{4r_1^2}}, \\ B &= \frac{a}{c} + \frac{r^2}{2r_2} + i\sqrt{r^2 - \frac{r^4}{4r_2^2}}, \end{aligned}$$

and

$$\begin{aligned} \sigma^{-1}(A) &= \frac{1}{c^2} \left( \frac{1}{2r_1} - cd + i\sqrt{\frac{1}{r^2} - \frac{1}{4r_1^2}} \right), \\ \sigma^{-1}(B) &= \frac{1}{c^2} \left( -\frac{1}{2r_2} + cd + i\sqrt{\frac{1}{r^2} - \frac{1}{4r_2^2}} \right). \end{aligned}$$

This means,

$$(25) \quad \lim_{r \rightarrow 0} \left| \int_{\sigma^{-1}(l_i)} dw \right| = \frac{1}{2c^2} \left( \frac{1}{r_1} + \frac{1}{r_2} \right) - 2\frac{d}{c} < \infty.$$

Because  $f$  is holomorphic except for  $i\infty$ , there exists  $M > 0$  which satisfies

$$(26) \quad \left| f\left(\frac{aw+b}{cw+d}\right) \right| \leq M < \infty$$

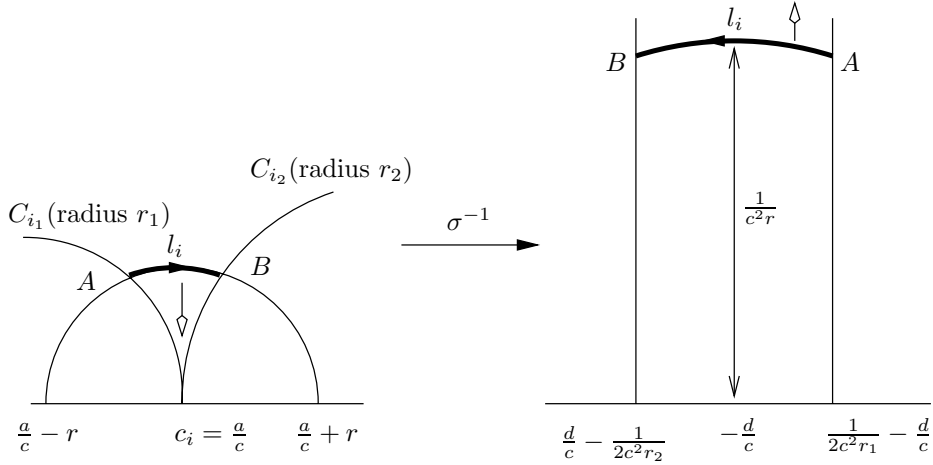

Figure 5: Change the variable

for the neighborhood of  $w = i\infty$ . Hence,

$$\begin{aligned} & \lim_{r \rightarrow 0} \left| \int_{\sigma^{-1}(l_i)} \frac{6if\left(\frac{aw+b}{cw+d}\right)}{\pi[SL_2(\mathbb{Z}) : \Gamma_0(N)](w-\bar{w})} \frac{|cw+d|^2}{(cw+d)^2} dw \right| \\ & \leq \frac{6}{\pi[SL_2(\mathbb{Z}) : \Gamma_0(N)]} \lim_{r \rightarrow 0} \int_{\sigma^{-1}(l_i)} \left| f\left(\frac{aw+b}{cw+d}\right) \right| \frac{|dw|}{|w-\bar{w}|} \\ & \leq \frac{6M}{\pi[SL_2(\mathbb{Z}) : \Gamma_0(N)]} \lim_{r \rightarrow 0} \left| \int_{\sigma^{-1}(l_i)} dw \right| c^2 r = 0. \end{aligned}$$

So we can see

$$\lim_{r \rightarrow 0} \int_{l_i} f(\tau) E_2^{(N)*}(\tau) d\tau = \lim_{r \rightarrow 0} \int_{\sigma^{-1}(l_i)} f\left(\frac{aw+b}{cw+d}\right) E_2^{(N)}\left(\frac{aw+b}{cw+d}\right) \frac{dw}{(cw+d)^2}.$$

Here if we show

$$(27) \quad \lim_{w \rightarrow i\infty} \frac{1}{(cw+d)^2} E_2^{(N)}\left(\frac{aw+b}{cw+d}\right) = 0,$$

then we can easily see

$$(28) \quad \lim_{r \rightarrow 0} \int_{\sigma^{-1}(l_i)} f\left(\frac{aw+b}{cw+d}\right) E_2^{(N)}\left(\frac{aw+b}{cw+d}\right) \frac{dw}{(cw+d)^2} = 0$$

by the equations (25) and (26), and complete the proof of the theorem.

For  $k \geq 3$ ,

$$\lim_{w \rightarrow i\infty} \frac{1}{(cw + d)^k} E_k^{(N)} \left( \frac{aw + b}{cw + d} \right) = 0$$

is valid because  $E_k^{(N)}$  is one of the Poincaé series of weight  $k$  for  $\Gamma_0(N)$ . (See Gunning [6, 28–34]) The equation (27) is for the case  $k = 2$ . To show (27), we put a new series

$$\Psi^{(N)}(\tau, s) = \sum_{\gamma \in \Gamma_\infty \backslash \Gamma_0(N)} \frac{1}{(c'\tau + d')^2 |c'\tau + d'|^s}, \quad \gamma = \begin{pmatrix} a' & b' \\ c' & d' \end{pmatrix}$$

where

$$\Gamma_\infty = \left\{ \begin{pmatrix} 1 & 1 \\ 0 & 1 \end{pmatrix}^n \mid n \in \mathbb{Z} \right\} \subset \Gamma_0(N).$$

This series converges absolutely and uniformly on any compact subset in  $\mathfrak{H}$  for  $\Re(s) \geq \varepsilon > 0$ . We put  $\rho = \begin{pmatrix} a & b \\ c & d \end{pmatrix} \in SL_2(\mathbb{Z}) \backslash \Gamma_0(N)$ , then

$$(29) \quad \Psi^{(N)}(\rho\tau, s) \cdot \frac{1}{(c\tau + d)^2 |c\tau + d|^s} = \sum_{\gamma \in \Gamma_\infty \backslash \Gamma_0(N)\rho} \frac{1}{(c'\tau + d')^2 |c'\tau + d'|^s}.$$

Let  $h$  is the width of the cusp  $\frac{a}{c}$ : i.e. the smallest integer  $h > 0$  which satisfies

$$\Gamma_\infty^* = \left\{ \begin{pmatrix} 1 & h \\ 0 & 1 \end{pmatrix} \mid n \in \mathbb{Z} \right\} \subset \rho^{-1} \Gamma_0(N) \rho,$$

then we can get the double coset representation  $\Gamma_\infty \backslash \Gamma_0(N) \rho / \Gamma_\infty^*$ , and we divide the summation of (29) by this double coset representation, that is

$$\begin{aligned} & \sum_{\gamma \in \Gamma_\infty \backslash \Gamma_0(N)\rho} \frac{1}{(c'\tau + d')^2 |c'\tau + d'|^s} \\ &= \sum_{\gamma \in \Gamma_\infty \backslash \Gamma_0(N)\rho / \Gamma_\infty^*} \sum_l \frac{1}{(c'\tau + c'hl + d')^2 |c'\tau + c'hl + d'|^s}, \end{aligned}$$

where  $l$  runs over  $\mathbb{Z}$  or  $1, 2, \dots, k$  according to the number of representative elements of  $(\Gamma_\infty \cap \gamma \Gamma_\infty^* \gamma^{-1}) \backslash \Gamma_\infty$ . That is, if the number of representative elements of  $(\Gamma_\infty \cap \gamma \Gamma_\infty^* \gamma^{-1}) \backslash \Gamma_\infty$  is infinity, then  $l$  runs over  $\mathbb{Z}$ , and if the number of representative elements is  $k$ , then  $l$  runs over  $1, 2, \dots, k$ . If we assume there exists  $\gamma \in \Gamma_0(N)$  such that

$$\Gamma_\infty \cap (\gamma\rho)\Gamma_\infty^*(\gamma\rho)^{-1} \neq \left\{ \begin{pmatrix} 1 & 0 \\ 0 & 1 \end{pmatrix} \right\},$$

then  $\gamma\left(\frac{a}{c}\right) = i\infty$ . But this is contradiction, because  $\frac{a}{c}$  is not  $\Gamma_0(N)$ -equivalent to  $i\infty$ . Hence we get,

$$\begin{aligned} & \Psi^{(N)}(\rho\tau, s) \cdot \frac{1}{(c\tau + d)^2|c\tau + d|^s} \\ &= \sum_{\gamma \in \Gamma_\infty \setminus \Gamma_0(N)\rho/\Gamma_\infty^*} \sum_{l=-\infty}^{\infty} \frac{1}{(c'\tau + c'hl + d')^2|c'\tau + c'hl + d'|^s}. \end{aligned}$$

This implies that the representative element  $\gamma = \begin{pmatrix} a' & b' \\ c' & d' \end{pmatrix} \in \Gamma_\infty \setminus \Gamma_0(N)\rho/\Gamma_\infty^*$  is not equal to  $\begin{pmatrix} * & * \\ 0 & * \end{pmatrix}$ , i.e  $c' \neq 0$ . So we get

$$\lim_{\tau \rightarrow i\infty} \sum_{l=-\infty}^{\infty} \frac{1}{(c'\tau + c'hl + d')^2|c'\tau + c'hl + d'|^s} = 0.$$

It is showed by the same way with the equation (4) that

$$\Psi^{(N)}(\tau, s) = 2 \prod_{\substack{p|N \\ p:\text{prime}}} \left(1 - \frac{1}{p^{2+s}}\right) \zeta(2+s)\Phi^{(N)}(\tau, s),$$

where  $\Phi^{(N)}$  is defined in Theorem 3.1. This indicates that  $\Psi^{(N)}$  is an entire function of  $s$ , so  $\Psi^{(N)}$  can continuous holomorphically to a neighborhood of  $s = 0$  and  $E_2^{(N)*}(\tau) = \Psi^{(N)}(\tau, 0)$ . Thus we get

$$\begin{aligned} & \lim_{\tau \rightarrow i\infty} E_2^{(N)*}(\rho\tau) \frac{1}{(c\tau + d)^2} \\ &= \lim_{\tau \rightarrow i\infty} \lim_{s \rightarrow 0} \Psi^{(N)}(\rho\tau, s) \cdot \frac{1}{(c\tau + d)^2|c\tau + d|^s} \\ &= \lim_{s \rightarrow 0} \lim_{\tau \rightarrow i\infty} \Psi^{(N)}(\rho\tau, s) \cdot \frac{1}{(c\tau + d)^2|c\tau + d|^s} \\ &= \lim_{s \rightarrow 0} \lim_{\tau \rightarrow i\infty} \sum_{\gamma \in \Gamma_\infty \setminus \Gamma_0(N)\rho/\Gamma_\infty^*} \sum_l \frac{1}{(c'\tau + c'hl + d')^2|c'\tau + c'hl + d'|^s} = 0. \end{aligned}$$

Because

$$E_2^{(N)*}(\tau) = E_2^{(N)}(\tau) - \frac{3}{\pi \Im(\tau)[SL_2(\mathbb{Z}) : \Gamma_0(N)]},$$

we get

**Proposition 5.1.** *Let  $\frac{a}{c}$  be the cusp for  $\Gamma_0(N)$  which is not equal  $i\infty$ , and  $\rho \in SL_2(\mathbb{Z})$  which satisfies  $\rho(i\infty) = \frac{a}{c}$ . Then, for  $k \geq 2$ ,*

$$\lim_{\tau \rightarrow i\infty} \frac{1}{(c\tau + d)^k} E_k^{(N)}(\rho\tau) = 0.$$

From this proposition and (28), we complete the proof of Theorem 2.

**6. The view from the theory of the open Riemann surface**

In this section, we observe the Atkin inner product for  $\Gamma_0(N)$  from the view point of the open Riemann surface theory. We deal with the open Riemann surface  $(\Gamma_0(N)\backslash\mathfrak{H})^* \setminus \{i\infty\}$ , where  $(\Gamma_0(N)\backslash\mathfrak{H})^*$  is the compactification of  $\Gamma_0(N)\backslash\mathfrak{H}$ .

Let  $\mathcal{H}^{(N)}$  be the space of all holomorphic functions on  $(\Gamma_0(N)\backslash\mathfrak{H})^* \setminus \{i\infty\}$ . If we put  $L_A(f) = (f, 1)_{(N)}$ , then  $L_A$  is a linear functional on  $\mathcal{M}^{(N)}$ . Because  $\Delta = \{\tau \in \mathcal{F} \mid \Im(\tau) > y \gg 0\}$  is a neighborhood of  $i\infty$ ,  $\{\Delta, q = e^{2\pi i\tau}\}$  is a local coordinate around  $i\infty \in (\Gamma_0(N)\backslash\mathfrak{H})^*$  and  $\partial\Delta \in (\Gamma_0(N)\backslash\mathfrak{H})^* \setminus \{i\infty\}$ . Then we can write

$$L_A(f) = \int_{\partial\Delta} f(q)E_2^{(N)}(q) \frac{dq}{q}.$$

Because the right hand side of the above equation is well-defined for  $f \in \mathcal{H}^{(N)}$ , we can think of  $L_A$  as a linear functional on  $\mathcal{H}^{(N)}$ .

Because  $E_2^{(N)}$  is not quite modular,  $E_2^{(N)}(q) \frac{dq}{q}$  is not a holomorphic differential on  $(\Gamma_0(N)\backslash\mathfrak{H})^*$ . But it is a holomorphic differential on  $\Delta$  from the property  $E_2^{(N)}(\tau + 1) = E_2^{(N)}(\tau)$ . From this property and the holomorphicity of  $f$  on  $(\Gamma_0(N)\backslash\mathfrak{H})^* \setminus \{i\infty\}$ , if  $\Delta_1, \Delta_2 \subset \Delta$  are neighborhoods around  $i\infty$  which have the Jordan closed curves  $\partial\Delta_i (i = 1, 2)$  as boundaries, then

$$\int_{\partial\Delta_1} f(q)E_2^{(N)}(q) \frac{dq}{q} = \int_{\partial\Delta_2} f(q)E_2^{(N)}(q) \frac{dq}{q}.$$

Let  $\{\Omega_i\}_{i \in \mathbb{N}}$  be the sequence of open sets of  $(\Gamma_0(N)\backslash\mathfrak{H})^* \setminus \{i\infty\}$  which satisfy

1. The closures  $\bar{\Omega}_i$  are compact sets in  $(\Gamma_0(N)\backslash\mathfrak{H})^* \setminus \{i\infty\}$ .
2. The boundaries  $\partial\Omega_i$  consist of finite connected components each of which is a Jordan curve.
3. The connected components of  $(\Gamma_0(N)\backslash\mathfrak{H})^* \setminus (\{i\infty\} \cup \bar{\Omega}_i)$  are not compact in  $(\Gamma_0(N)\backslash\mathfrak{H})^* \setminus \{i\infty\}$ .
4.  $\bar{\Omega}_i \subset \Omega_{i+1} (i \in \mathbb{N})$  and  $\cup_{i \in \mathbb{N}} \Omega_i = (\Gamma_0(N)\backslash\mathfrak{H})^* \setminus \{i\infty\}$ .

Then there exists a large number  $i \in \mathbb{N}$  such that  $\bar{\Omega}_i$  contains  $\partial\Delta$ . For  $j \geq i$ ,  $(\Gamma_0(N)\backslash\mathfrak{H})^* \setminus \bar{\Omega}_j$  have the same property with  $\Delta_i$ , thus we get

$$L_A(f) = - \int_{\partial\Omega_j} f(q)E_2^{(N)}(q) \frac{dq}{q}.$$

for  $j \geq i$ . We call the domain  $\Omega$  which satisfies the above conditions 1, 2 and 3 a normal region in  $(\Gamma_0(N)\backslash\mathfrak{H})^* \setminus \{i\infty\}$ , and a sequence of normal regions which

satisfies the above condition 4 a canonical exhaustion of  $(\Gamma_0(N)\backslash\mathfrak{H})^* \setminus \{i\infty\}$ . Thus we get the expression

$$(30) \quad L_A(f) = - \lim_{n \rightarrow \infty} \int_{\partial\Omega_n} f(q)E_2^{(N)}(q) \frac{dq}{q}.$$

Moreover, if the sequence  $\{f_n\}_{n \in \mathbb{N}}$  ( $f_n \in \mathcal{H}^{(N)}$ ) converges to 0 absolutely and uniformly on any compact subset of  $(\Gamma_0(N)\backslash\mathfrak{H})^* \setminus \{i\infty\}$ , then

$$\begin{aligned} |L_A(f_n)| &\leq \int_{\partial\Delta} \left| f_n(q)E_2^{(N)}(q) \right| \left| \frac{dq}{q} \right| \\ &\leq \int_{\partial\Delta} |dq| \max_{\partial\Delta} \left\{ f_n(q) \frac{E_2^{(N)}(q)}{q} \right\} \longrightarrow 0 \quad \text{as } n \rightarrow \infty. \end{aligned}$$

Then we call  $L_A$  a holomorphic functional.

Thus we can think of the Atkin inner product for  $\Gamma_0(N)$  as one of the holomorphic linear functional on the open Riemann surface  $(\Gamma_0(N)\backslash\mathfrak{H})^* \setminus \{i\infty\}$ . This is the reason of calling the Atkin inner product for  $\Gamma_0(N)$  “at  $i\infty$ ”.

Next, we see that the Atkin inner product for  $\Gamma_0(N)$  is one of the examples of the representative theory of the holomorphic functional. Let  $\mathcal{H}^{(N)}(i\infty)$  be the set of all functions which are holomorphic on  $(\Gamma_0(N)\backslash\mathfrak{H})^* \setminus (\{i\infty\} \cup \mathfrak{C})$ , where  $\mathfrak{C}$  is an arbitrary compact set of  $(\Gamma_0(N)\backslash\mathfrak{H})^* \setminus \{i\infty\}$ . Then  $\mathcal{H}^{(N)} \subset \mathcal{H}^{(N)}(i\infty)$  is clear. The representative theory is the following.

**Theorem 6.1.** *Let  $L$  be a holomorphic functional on  $(\Gamma_0(N)\backslash\mathfrak{H})^* \setminus \{i\infty\}$ ,  $\{\Omega_n\}_{n \in \mathbb{N}}$  a canonical exhaustion of  $(\Gamma_0(N)\backslash\mathfrak{H})^* \setminus \{i\infty\}$  and  $\omega$  an Abelian differential of the first kind on  $(\Gamma_0(N)\backslash\mathfrak{H})^* \setminus \{i\infty\}$  which has no zero point. Then there exists a function  $h \in \mathcal{H}^{(N)}(i\infty)$  which satisfies*

$$L(f) = \lim_{n \rightarrow \infty} \int_{\partial\Omega_n} fh\omega$$

for all  $f \in \mathcal{H}^{(N)}$ . Moreover the function  $h$  is unique modulo  $\mathcal{H}^{(N)}$ .

We remark that

$$\lim_{n \rightarrow \infty} \int_{\partial\Omega_n} fh\omega$$

is well-defined for all  $h \in \mathcal{H}^{(N)}(i\infty)$  because of the same reason of the Atkin’s one. This theory says that

$$\mathcal{H}^{(N)}(i\infty)/\mathcal{H}^{(N)} \cong \text{All holomorphic functional on } (\Gamma_0(N)\backslash\mathfrak{H})^* \setminus \{i\infty\}.$$

This is called the Köthe duality theorem.

We compare the above theory with the expression (30), then we get

$$h\omega = -E_2^{(N)}(q) \frac{dq}{q} \quad \left( \text{modulo } \mathcal{H}^{(N)}\omega \right).$$

Thus the Atkin inner product for  $\Gamma_0(N)$  is one of the example of the above theorem.

We have so far studied the Atkin inner product for  $\Gamma_0(N)$  at  $i\infty$ . However, these arguments are valid for other cusps  $\neq i\infty$ . These cusps are special points which make  $\Gamma_0(N)\backslash\mathfrak{H}$  the compact Riemann surface  $(\Gamma_0(N)\backslash\mathfrak{H})^*$ , but, viewed as points on the Riemann surface of  $(\Gamma_0(N)\backslash\mathfrak{H})^*$ , cusps have no special meaning. Thus, we have the following questions.

1. Does there exist a holomorphic functional on  $(\Gamma_0(N)\backslash\mathfrak{H})^*\backslash\{p \neq \text{cusp}\}$  which is equivalent to the Atkin inner product for  $\Gamma_0(N)$ ?
2. If such holomorphic function exists, then there exists a differential which is equivalent to  $h\omega$  in Theorem 6.1. How do we write this differential concretely?

### Acknowledgements

The author expresses his sincere thanks to his supervisor Professor Masanobu Kaneko, who gave him helpful advice and introduced him to the Atkin inner product for  $SL_2(\mathbb{Z})$  which motivated the present work.

DEPARTMENT OF MATHEMATICS  
SHIMANE UNIVERSITY  
MATSUE 690-8504, JAPAN  
e-mail: tsutsumi@math.shimane-u.ac.jp

### References

- [1] R. E. Borcherds, Automorphic forms with singularities on grassmannians, *Inv. Math.*, **132** (1998), 491–562.
- [2] E. Hecke, Analytische funktionen und algebraische Zahlen. Zweiter teil, *Mathematische Werke*, 1970, 381–404.
- [3] H. Poincaré, Théorie des groupes fuchsien, *Acta Mathematica*, 1882, 1-60.
- [4] Y. Kawata, Theory of modular functions of one variable (I), *Seminar note*, no. 4, University of Tokyo, 1963, in Japanese.
- [5] M. Kaneko and D. Zagier, Supersingular  $j$ -invariants, hypergeometric series and Atkin's orthogonal polynomials, *AMS/IP Studies in Advanced Mathematics*, **7** (1998), 97–126.
- [6] R. C. Gunning, *Lectures on modular forms*, *Annals of Mathematics Studies* Vol. 48, Princeton University Press, 1962.