

HEIGHT FUNCTIONS ON SURFACES WITH THREE CRITICAL POINTS

BY

THOMAS BANCHOFF¹ AND FLORIS TAKENS

We shall consider the following question: Under what conditions can we find an embedding or an immersion $f: M^2 \rightarrow E^3$ of a closed surface M^2 into Euclidean 3-space such that there is a linear function on E^3 , $z: E^3 \rightarrow \mathbf{R}$, so that the composition $z \circ f: M^2 \rightarrow \mathbf{R}$ has exactly three critical points, one of which may be degenerate. This question for a smooth embedding f was suggested as an exercise by H. Hopf in [6, p. 92]. The only possibility of a three critical point (3cp) smooth embedding is the case of a 2-sphere embedded as a "shoe surface" (see Figure 1).

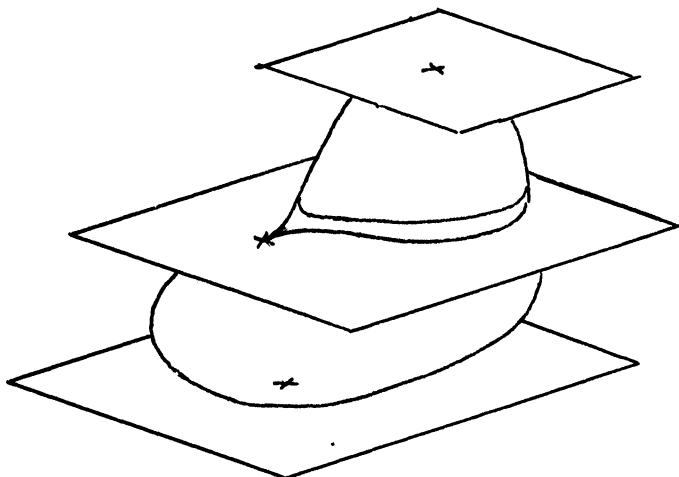

FIGURE 1

When we consider smooth immersions or polyhedral embeddings or immersions, the results are quite different. In this note, we prove the following results.

THEOREM 1. *There is a smooth 3cp immersion of the torus but there is no smooth 3cp immersion for any orientable surface of genus greater than one.*

THEOREM 2. *There is a smooth 3cp immersion of any nonorientable surface.*

These immersions can be approximated by polyhedral 3cp immersions but in the polyhedral case we have an entirely different phenomenon:

Received August 25, 1972.

¹ Partially supported by National Science Foundation grants.

THEOREM 3. *For any orientable surface except the sphere there is a polyhedral 3cp embedding into E^3 .*

We remark that these questions are related to the factorization problems studied by Haefliger in [3], where he solved the problem of determining when an “excellent” mapping $k: M^2 \rightarrow E^2$ could be expressed as the composition of an immersion $f: M^2 \rightarrow E^3$ and the orthogonal projection $\pi: E^3 \rightarrow E^2$. Since for any surface M^2 there are functions $h: M^2 \rightarrow \mathbf{R}$ with exactly three critical points, our result may be considered as an attempt to factorize some such h as an immersion or embedding $f: M^2 \rightarrow E^3$ followed by an orthogonal projection into a line.

The examples of 3cp polyhedral embeddings given in Section 5 have been used as motivation for a study of the extensions of the idea of the degree of the Gauss spherical mapping to polyhedral embeddings in [1].

In Section 1 of this paper we deal with arbitrary functions h with three critical points on surfaces. In Section 2 we examine those functions of the form $h = zf$ and we develop the rotation number results which we need in Section 3 to prove Theorem 1. Section 4 treats smooth 3cp immersions of nonorientable surfaces and contains the proof of Theorem 2. The final section, which proves Theorem 3, deals with polyhedral embeddings and can be read directly after Section 1.

1. Functions with three critical points on closed surfaces

Let $h: M^2 \rightarrow \mathbf{R}$ be a function with exactly three critical points, a minimum p_1 with value $h(p_1) = a$, a maximum p_2 with $h(p_2) = b$, and a middle critical point p_0 with $h(p_0) = 0$. For any other point p of M^2 the function h is ordinary, i.e. there is a neighborhood U of p and a function $h': M \rightarrow \mathbf{R}$ such that $(h|U, h'): U \rightarrow \mathbf{R} \oplus \mathbf{R}$ is a (differentiable or polyhedral) homeomorphism. For any t just below b or just above a , the level curve

$$M(t) = \{p \in M^2 \mid h(p) = t\}$$

is a simple closed curve. Since the form of the level curve can only change at a critical point, and sets

$$M^+ = \{p \in M^2 \mid h(p) > 0\} \quad \text{and} \quad M^- = \{p \in M^2 \mid h(p) < 0\}$$

are both open 2-discs. The level set $M(0)$ consists of p_0 together with N arcs with both endpoints at p_0 . (This result is discussed in detail in [5]. Another proof can be constructed using ideas in [7, Lemma 3.2].) We thus have a cell decomposition of M^2 into one vertex, N 1-cells, and two 2-cells so $\chi(M^2) = 1 - N + 2 = 3 - N$. If M^2 is orientable so that $\chi(M^2) = 2 - 2g$, then $N = 2g + 1$.

There is a disc neighborhood U of p_0 in M^2 such that $M(0) \cap U$ consists of $2N$ disjoint arcs with one endpoint at p_0 and the other at points q_1, q_2, \dots, q_{2n} in cyclic order on the boundary curve ∂U , indexed so that the (clockwise) arc on ∂U from q_{2r-1} to q_{2r} lies in M^+ for each r from 1 to N . The complement

$M(0) - U$ will consist of N arcs γ_{ij} joining disjoint point pairs (q_i, q_j) . For any sufficiently small $t > 0$, say $t < \varepsilon$, the set $M(t)$ will consist of N arcs $\gamma_{ij}(t)$ near γ_{ij} in $M(r) - U$ connecting disjoint point pairs $(q_i(t), q_j(t))$ in $\partial U \cap M^+$ along with N disjoint arcs $\alpha_r(t)$ in $M(t) \cap U \cap M^+$ connecting the disjoint point pairs $q_{2r-1}(t)$ and $q_{2r}(t)$. Similarly for $-\varepsilon < t < 0$ we have N arcs $\gamma_{ij}(t)$ near γ_{ij} joining $q_i(t)$ to $q_j(t)$ in $(M(t) - U) \cap M^-$ and arcs $\beta_r(t)$ in $M(t) \cap U \cap M^-$ joining $q_{2r}(t)$ to $q_{2r+1}(t)$ (with $q_{2n}(t)$ being joined to $q_1(t)$). The set

$$M[-\varepsilon, \varepsilon] = \{p \in M^2 \mid -\varepsilon \leq h(p) \leq \varepsilon\}$$

can then be expressed as a union of a disc $M[-\varepsilon, \varepsilon] \cap U$ bounded by $2N$ arcs

$$q_i[-\varepsilon, \varepsilon] = \{q_i(t) \mid -\varepsilon \leq t \leq \varepsilon\}$$

and arcs $\alpha_r(\varepsilon), \beta_r(\varepsilon), 0 \leq r \leq N$, together with N strips

$$\gamma_{ij}[-\varepsilon, \varepsilon] = \{\gamma_{ij}(t) \mid -\varepsilon \leq t \leq \varepsilon\}$$

attached to the disc at $q_i[-\varepsilon, \varepsilon]$ and $q_j[-\varepsilon, \varepsilon]$.

If γ_{ij} joins two points q_i and q_j with indices of the same parity then the arcs $q_i[-\varepsilon, \varepsilon]$ and $q_j[-\varepsilon, \varepsilon]$ have the same orientation on the boundary of $M[-\varepsilon, \varepsilon] \cap U$ so the union of $M[-\varepsilon, \varepsilon] \cap U$ and $\gamma_{ij}[-\varepsilon, \varepsilon]$ is a Mobius band and M^2 is nonorientable. It follows that if M^2 is orientable then all arcs γ_{ij} join points with indices with different parity. If we orient the curve $M[\varepsilon]$, so that the curve enters U at $q_1(\varepsilon)$ and leaves at $q_2(\varepsilon)$, then each oriented arc $\gamma_{ij}(\varepsilon)$ must have its first index even and its second index odd, and all arcs $\alpha_r(\varepsilon)$ are oriented from $q_{2r-1}(\varepsilon)$ to $q_{2r}(\varepsilon)$. In this case we may orient $M(-\varepsilon)$ as well so that the arcs $\beta_r(-\varepsilon)$ are oriented from $q_{2r+1}(-\varepsilon)$ to $q_{2r}(-\varepsilon)$ and the orientation on $\gamma_{ij}(-\varepsilon)$, from the even to the odd index, induces a similar orientation on each arc γ_{ij} of $M(0)$ which agrees with the one induced by the orientation on $M(\varepsilon)$.

See Figure 2 for three examples of level curves of functions with three critical points.

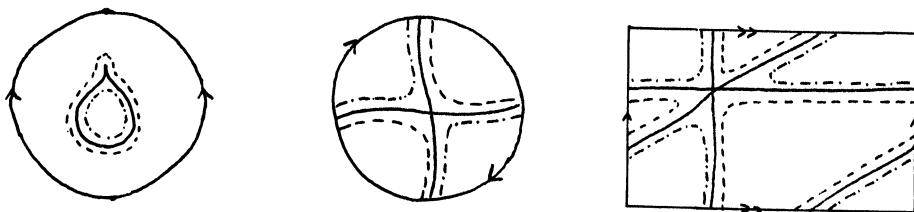

FIGURE 2

Sphere, $N = 1$; projective plane, $N = 2$; torus, $N = 3$

2. Differentiable height functions with three critical points and rotation numbers

Let $f: M^2 \rightarrow E^3$ be a differentiable immersion and let $z: E^3 \rightarrow \mathbf{R}$ be a linear function so that the composition $h = z \circ f, h(p) = z(f(p))$ has exactly three

critical points. Then the function $f| M(t)$ for $a < t < 0$ or $0 < t < b$ is an immersion of the curve $M(t)$ into the plane

$$E^2(t) = \{x \in E^3 \mid z(x) = t\}.$$

Let $\pi: E^3 \rightarrow E^2 (= E^2(0))$ denote the orthogonal projection and set $g_t = \pi \circ f| M(t)$, so for each $t \neq 0$ between a and b , g_t is an immersion of a circle $M(t)$ into the plane E^2 . For sufficiently small $\varepsilon > 0$, the immersion $g_{b-\varepsilon}$ will be an embedding and the family $\{g_t \mid \varepsilon \leq t \leq b - \varepsilon\}$ gives a regular homotopy between the immersion g_ε and the embedding $g_{b-\varepsilon}$. If we orient all the curves $M(t)$, $t > 0$, in the same way then each of the immersions g_t has a well defined rotation number $W(g_t)$. This rotation number is preserved under regular homotopy so $W(g_\varepsilon) = W(g_{b-\varepsilon}) = \pm 1$ since the rotation number of an embedding is ± 1 . Similarly $W(g_{-\varepsilon}) = W(g_{a+\varepsilon}) = \pm 1$.

We use the following notations in computing the rotation number of a smooth immersion g of a circle S . We consider an oriented line l in E^2 and define $W(g, p, l) = 1$ (respectively -1) if the oriented tangent line to $g(S)$ at $g(p)$ coincides with the line parallel to l through $g(p)$ and if a neighborhood of p on S has image to the right (respectively left) of this line, and we set $W(g, p, l) = 0$ otherwise. If l is chosen such that $W(g, p, l) = 0$ for only finitely many p in s , we set $W(g, l) = \sum_{p \text{ in } S} W(g, p, l)$ and this rotation number $W(g) = W(g, l)$ is independent of the line chosen.

3. Smooth 3cp immersions of orientable surfaces

Let $f: M^2 \rightarrow E^3$ be a smooth 3cp immersion of an orientable surface, so that at each point $f(p)$ there is a well-defined tangent plane. In particular at $f(p_0)$ the tangent plane is $E^2 (= E^2(0))$ and we find a disc neighborhood U of p_0 in M^2 such that $\pi \circ (f| U)$ maps U homeomorphically to an open disc in E^2 . We may assume that the neighborhood U is chosen to fulfill the conditions of the previous paragraphs of Section 1.

The set $f(U)$ may then be described as the graph of some function $F: \pi \circ f(U) \rightarrow \mathbf{R}$ determined by the condition that (x, y, z) is in $f(U)$ if and only if $z = F(x, y)$, for any (x, y) in $\pi \circ f(U)$. The function F is then itself a differentiable function of two variables over the domain $\pi \circ f(U)$ with precisely one critical point at $0 = f(p_0)$, and the set $F^{-1}(0)$ consists of an even number, say $2N$, of differentiable arcs from 0. We need to know the behavior of the function F near 0, and using the techniques of [5], we proceed to modify F to a function such that the behavior we are interested in takes the simplest possible form. We may choose open sets V and W with $0 \in V \subset \bar{V} \subset W \subset \bar{W} \subset U$ and a function \tilde{F} defined on $\pi \circ f(U)$ such that (i) \tilde{F} coincides with F in $\pi \circ f(U) - \pi \circ f(W)$, (ii) \tilde{F} has only one critical point in $\pi \circ f(U)$, and (iii) in V , $\tilde{F}(x, y) = \text{real part of } (x + iy)^N$ if $N > 1$ and $x^3 - y^2$ if $N = 1$. We may then define a new immersion $\tilde{f}: M^2 \rightarrow E^2$ by setting $\tilde{f}(p) = f(p)$ if $p \notin U$ and

$\tilde{f}(p) = (\pi \circ f(p), \tilde{F} \circ \pi \circ f(p))$ if $p \in U$. The natural mapping from $f(U)$ to $\tilde{f}(U)$ will be continuous everywhere and differentiable except perhaps at $f(p_0)$. We assume that such a modification has been carried out if necessary and we continue to write f instead of \tilde{f} . This classification is implicit in [5].

To compute the rotation numbers of the immersions g_ε and $g_{-\varepsilon}$, choose an oriented line l not parallel to any of the $2N$ rays tangent to the curves emanating from 0 in $F^{-1}(0)$. For sufficiently small ε , the points of $M(\varepsilon)$ and $M(-\varepsilon)$ outside of a small neighborhood D of $f(p_0)$ with $W(g_\varepsilon, p, l) \neq 0$ or $W(g_{-\varepsilon}, p, l) \neq 0$ are in 1-1 correspondence with equal algebraic signs. The difference $W(g_\varepsilon) - W(g_{-\varepsilon})$ depends only on the points in D in arcs $g_\varepsilon(\alpha_r(\varepsilon))$ or $g_{-\varepsilon}(\beta_r(-\varepsilon))$ with oriented tangent lines parallel to l . We may, and do, assume that D is contained in $\pi^{-1}\pi \circ f(V)$ (see construction of \tilde{F}) so that we can use the explicit formula for \tilde{F} there to find the contributions inside D to the winding numbers of g_ε and $g_{-\varepsilon}$.

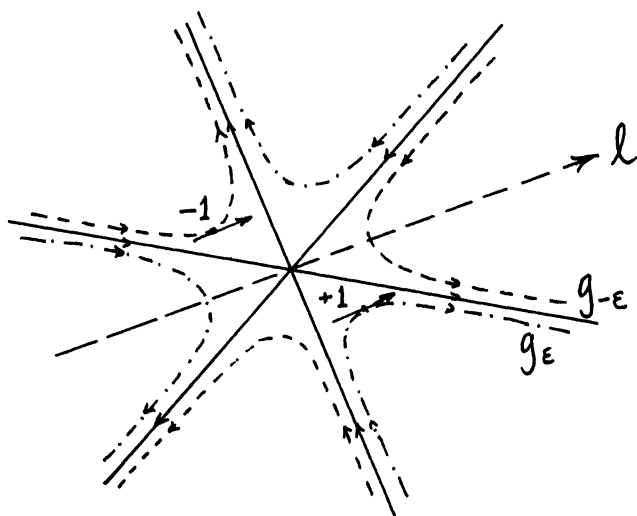

FIGURE 3

We easily see from Figure 3 that $W(g_\varepsilon) - W(g_{-\varepsilon}) = N - 1 = 2 - \chi(M^2)$.

In order to obtain an 3cp embedding of a surface we must have $W(g_\varepsilon) = W(g_{-\varepsilon}) = 1$ so $\chi(M^2) = 2$ and M^2 is a sphere. In the smooth case there is an embedding which satisfies this condition—a “shoe” embedding with one maximum, one minimum, and a middle critical point, where $f(M)$ is locally of the form $(x, y, x^3 - y^2)$. (See Figure 1.)

The above result allows for the possibility of a 3cp immersion with $W(g_\varepsilon) = 1$, $W(g_{-\varepsilon}) = -1$, and $0 = \chi(M^2)$, and we describe such an immersion by exhibiting the images $f(M(0))$, $g_\varepsilon(M(\varepsilon))$, and $g_{-\varepsilon}(M(-\varepsilon))$. (See Figure 4.)

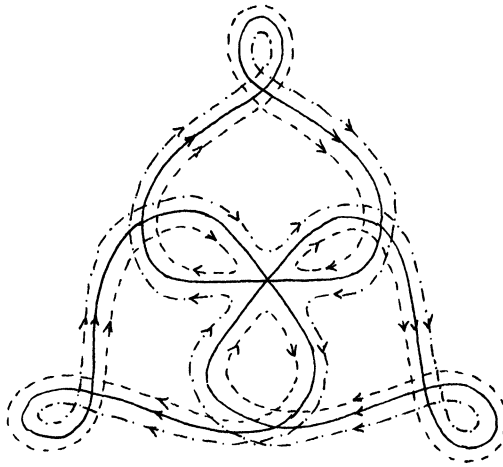

FIGURE 4

We may easily check that the immersions g_ε and $g_{-\varepsilon}$ have winding numbers $+1$ and -1 , respectively. By the Whitney-Graustein Theorem, these curves may be deformed by regular homotopies to circles.

4. Smooth 3cp immersions of nonorientable surfaces

For a nonorientable surface M^2 if $f: M^2 \rightarrow E^3$ is a 3cp immersion, then the set $M[-\varepsilon, \varepsilon]$ will be nonorientable so one of the strips $\gamma_{ij}[-\varepsilon, \varepsilon]$ will join a pair of arcs $q_i[-\varepsilon, \varepsilon]$ and $q_j[-\varepsilon, \varepsilon]$ with indices of the same parity. For example we obtain a 3cp immersion of the projective plane (see Figure 5).

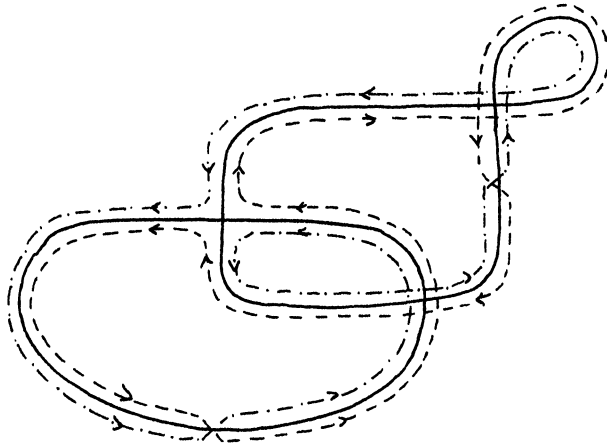

FIGURE 5

(This immersion was described by Kuiper in [4], p. 88.) Again, the curves $M(\varepsilon)$ and $M(-\varepsilon)$ can be oriented so that each of the immersions g_ε and $g_{-\varepsilon}$ has winding number $+1$ (even though it is impossible to orient both so that the orientations induced on the arcs of $f(M(0))$ agree).

In order to obtain 3cp immersions of other nonorientable surfaces we modify this example for the projective plane as follows: In the configuration formed by two adjacent wedges at $f(p_0)$ we modify the curve $M(0)$ by adding a curve which will not change $W(g_\varepsilon)$ or $W(g_{-\varepsilon})$ so both stay at ± 1 but which decreases the Euler characteristic by 1. In this way we can obtain 3cp immersions of all nonorientable surfaces. (See Figure 6).

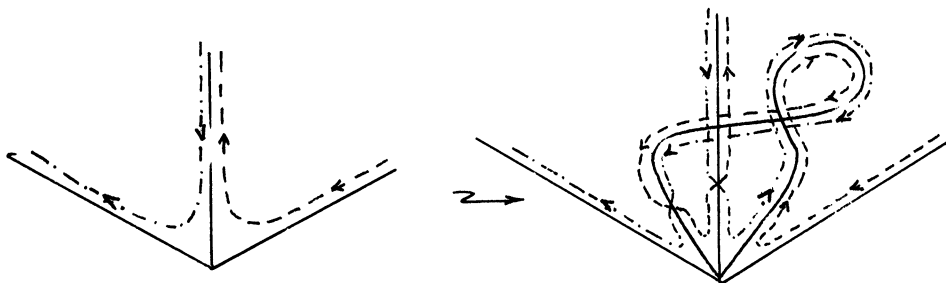

FIGURE 6

5. Polyhedral 3cp embeddings of orientable surfaces

To introduce the difference between the smooth and the polyhedral case, we exhibit a polyhedral torus and a height function with precisely three critical points. Between the levels $t = 1$ and $t = 2$, the surface is the cone from $(0, 0, 2)$ over the closed polygon with vertices $(-2, 2, 1), (-2, 0, 1), (-1, 0, 1), (-1, 1, 1), (1, 1, 1), (-1, -1, 1), (1, -1, 1), (1, 0, 1), (2, 0, 1), (2, 2, 1)$. Between $t = -2$ and $t = -1$, the surface is the cone from $(0, 0, -2)$ over the polygon $(-2, 2, -1), (-2, 0, -1), (-1, 0, -1), (-1, -1, -1), (1, -1, -1), (-1, 1, -1), (1, 1, -1), (1, 0, -1), (2, 0, -1), (2, 2, -1)$.

Between $t = -1$ and $t = +1$, the surface consists of vertical strips over the segments from $(-1, -1, -1)$ to $(-1, 1, -1)$, from $(1, -1, -1)$ to $(1, 1, -1)$ and over the polygonal arc $(-1, 0, -1), (-2, 0, -1), (-2, 2, -1), (2, 2, -1), (2, 0, -1), (1, 0, -1)$, together with the cone from the origin over the polygon on the unit cube with vertices $(1, 1, 1), (1, 1, -1), (1, 0, -1), (1, 0, 1), (1, -1, 1), (1, -1, -1), (-1, 1, -1), (-1, 1, 1), (-1, 0, 1), (-1, 0, -1), (-1, -1, -1), (-1, -1, 1)$.

The intersection of this surface with any plane $\{(x, y, z) \mid z = t\}$ for $-1 < t < 0$ or $0 < t < 1$ is a simple closed polygon, and every vertex is ordinary for the z -coordinate direction except for the maximum at $(0, 0, 2)$, the minimum at $(0, 0, -2)$, and a third critical point at the origin $(0, 0, 0)$.

The intersection of the polyhedron with the plane $z = 0$ consists of three polygonal arcs with both endpoints at the origin. The Euler characteristic of the surface is then 0 by the formula from Section 2, and since any embedded surface is necessarily orientable, the surface is a torus.

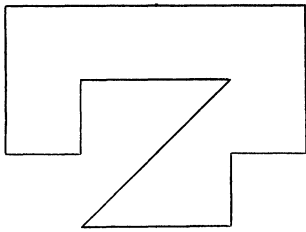

FIGURE 7
Level $t = 1$

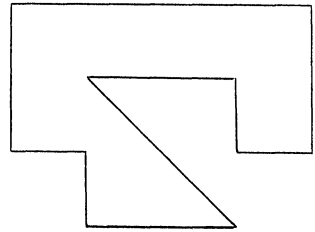

FIGURE 8
Level $t = -1$

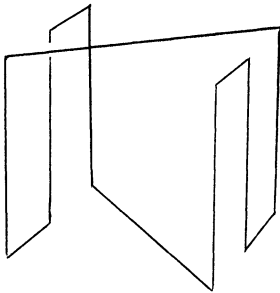

FIGURE 9

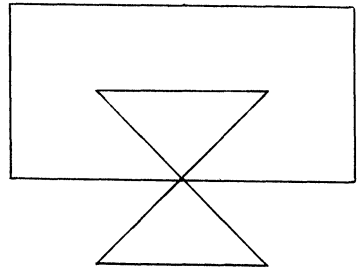

FIGURE 10
Level $t = 0$

In a similar way we may obtain 3cp polyhedral embeddings of orientable surfaces with Euler characteristic ≤ 0 . For example in Figure 11 we give the level curves at $t = -1$, $t = 0$, and $t = 1$ for a 3cp embedding of a surface of genus 2 and Euler characteristic -2 .

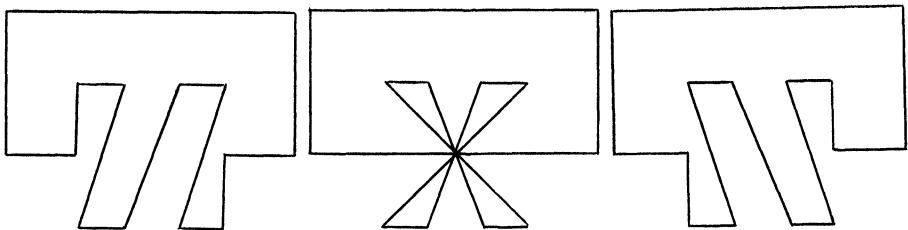

FIGURE 11

Remarks. The key fact that makes the polyhedral situation so different from the smooth case is that in the smooth case the topological form of any isolated critical point is completely determined up to a reflection by the level set of the surface through the critical point. This follows since for any point of a smooth surface there is a neighborhood such that the orthogonal projection to some plane is one-to-one (the tangent plane of the surface for example). This property is not true in general for polyhedral embeddings.

Generally we may describe an isolated critical point p_0 of a height function zf on an embedded polyhedron by taking a neighborhood

$$M(c - \epsilon, c + \epsilon) = \{p \in M \mid c - \epsilon < zf(p) < c + \epsilon\}$$

such that there are no vertices of M on any polygon $M(t)$ for $c - \epsilon < t < c$ and $c < t < c + \epsilon$, where $zf(p_0) = c$. The polygon $M(c)$ then consists of a collection of disjoint embedded closed curves together with a number, N , of polygonal arcs beginning and ending at $f(p_0)$. These arcs meet a small disc $D(c)$ about $f(p_0)$ in the plane $E^2(c) = \{x \in E^3 \mid zx = c\}$ in a collection of segments from $f(p_0)$ to points $f(q_i)$, $i = 1, 2, \dots, 2N$. The part of M with the image lying in the cylinder $D(c) \times [c - \epsilon, c + \epsilon]$ over $D(c)$ is then a 2-dimensional disc neighborhood B^2 of p_0 back in M , and the image of this disc will be a cone from $f(p_0)$ over a curve consisting of pieces of helix on the boundary $\partial D(c) \times [c - \epsilon, c + \epsilon]$ joining $f(q_i)$ to $f(q_i^+)$ on $\partial D(c + \epsilon)$ and to $f(q_i^-)$ on $\partial D(c - \epsilon)$, together with polygonal arcs in the end discs $D(c - \epsilon)$ and $D(c + \epsilon)$ joining points $f(q_i^+)$ to $f(q_j^+)$ or $f(q_i^-)$ to $f(q_k^-)$.

If the isolated critical point is equivalent to an isolated critical point of a height function on a smoothly embedded or immersed surface, then the points q_i occur in *cyclic order* in the boundary of B^2 , i.e. $f(q_i^+)$ is connected to $f(q_{i+1}^+)$ and $f(q_i^-)$ is connected to $f(q_{i-1}^-)$ for all indices i (or this ordering may be reversed). It is this restriction which limits the possibilities of embedding or immersing orientable surfaces smoothly into E^3 . We have this same restriction if we consider only imbeddings for which each point possesses a “transversal” plane, onto which a sufficiently small neighborhood of the point projects in a one-to-one way. (See Figure 12.) In the polygonal case however, there is no

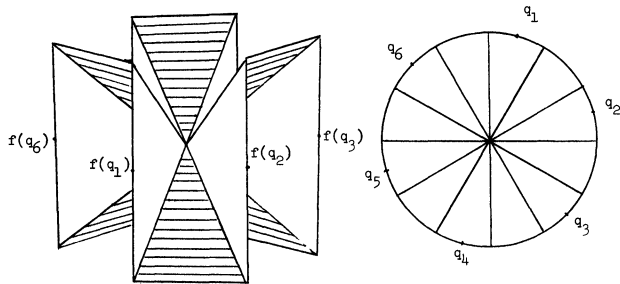

FIGURE 12

reason why the points q_i should be traced in cyclic order and indeed they are not traced cyclically in the examples presented at the beginning of this section. For example, the middle critical point has the points q_i , $i = 1, 2, \dots, 6$ traced in the order $q_1, q_4, q_3, q_2, q_5, q_6$. (See Figure 13.)

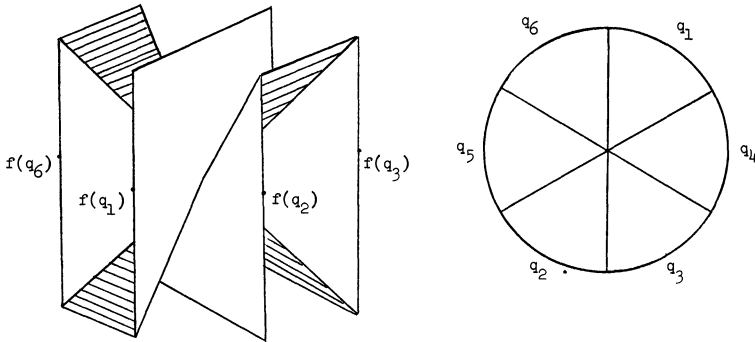

FIGURE 13

For this embedded polyhedral disc there is no plane onto which the orthogonal projection is one-to-one, and indeed it is possible to show that for any 3cp polyhedral embedding of an orientable surface other than the sphere, no neighborhood of the middle critical point will project orthogonally into any plane in a one-to-one way. This theorem and other results relating to the theory of spherical images of polyhedral immersions will be presented in [1].

Remark. For a smoothly embedded or immersed surface in Euclidean 3-space, almost all height functions will have only nondegenerate critical points, so for a surface of Euler characteristic $2 - k$ there must be at least one maximum, at least one minimum, and at least k nondegenerate saddles, so the *average* number of critical points over all height functions in E^3 is greater than or equal to $2 + k$. For the polyhedral case, however, if there is a height function z such that $z \circ f$ has exactly three critical points, then for z' sufficiently close to z , the height function $z' \circ f$ also has exactly three critical points. An example of a polyhedral embedding of the torus for which the average number of critical points is less than 4 is given by the torus constructed by Császár [2]. This embedding has only seven vertices and every pair of vertices determines an edge of the embedded polyhedral surface. This embedding is *tight* in the sense that each height function has at most one strict local maximum and one strict local minimum, so there can be at most two other critical levels, and therefore at most four critical points. Since for certain directions there are exactly three critical points, it follows that the *average* number of critical points for this embedding is less than four although for any smooth embedding or immersion of the torus, the average number of critical points is at least four.

REFERENCES

1. T. BANCHOFF, *The Gauss mapping and spherical degree for polyhedral hypersurfaces*, to appear.
2. A. CSÁSZÁR, *A polyhedron without diagonals*, Acta, Sci. Math., vol. 13 (1949), pp. 140–142.
3. A. HAEFLIGER, *Quelques remarques sur les applications différentiables d'une surface dans le plan*, Ann. Inst. Fourier, Grenoble, vol. 10 (1960), pp. 47–60.
4. N. KUIPER, *Convex immersions of closed surfaces in E^3* , Comm. Math. Helv., vol. 35 (1961), pp. 85–92.
5. H. SCHILT, *Über die Isolierten Nullstellen der Flächenkrümmung*, Compositio Math., vol. 5 (1937), pp. 239–283.
6. H. SEIFERT AND W. THRELFALL, *Variationsrechnung im Grossen*, Teubner Verlag, Berlin, 1938.
7. F. TAKENS, *The minimal number of critical points of a function on a compact manifold and the Lusternik-Schnirelman category*, Invent. Math., vol. 6 (1968), pp. 197–244.

BROWN UNIVERSITY
PROVIDENCE, RHODE ISLAND
UNIVERSITY OF GRONINGEN
THE NETHERLANDS