

HARMONIC SHEARS OF ELLIPTIC INTEGRALS

MICHAEL DORFF AND J. SZYNAL

ABSTRACT. We shear complex elliptic integrals to create univalent harmonic mappings and then use the Weierstrass-Enneper formula to construct embedded minimal surfaces. In one particular case we use this approach to construct a family of slanted Scherk's doubly periodic surfaces whose limit is the helicoid. The corresponding conjugate surfaces form a family of Scherk's singly periodic surfaces that transform into the catenoid. These particular families of surfaces are significant in the study of minimal surfaces, and this method of shearing analytic functions to construct them is a novel approach.

1. Introduction. A harmonic mapping is a complex-valued function $f = u + iv$, for which both u and v are real harmonic. Throughout this paper we will discuss harmonic functions that are univalent and sense-preserving on $\mathbf{D} = \{z : |z| < 1\}$. Such mappings can be written in the form $f = h + \bar{g}$, where h and g are analytic and $|h'(z)| > |g'(z)|$ [2]. Constructing mappings with these properties is difficult. However, Clunie and Sheil-Small introduced a shearing method on a certain class of analytic functions for doing so. A few recent papers have used this shearing technique [4, 15]. In this paper we apply this shearing method to complex elliptic integrals.

One nice aspect of these univalent harmonic mappings is that they lift to embedded, i.e., nonself-intersecting, minimal surfaces via the Weierstrass-Enneper representation formula. Lifting the harmonic mappings formed by the shearing of complex elliptic integrals results in some interesting minimal surfaces. In particular, the minimal graphs associated with the shearing of a particular elliptic integral of the first kind form a one-parameter family of slanted Scherk's surfaces that range from the canonical Scherk's first, or doubly periodic, surface to the helicoid. Doubly periodic minimal surfaces have been studied and classified by minimal surface theorists [9, 12, 17]. Our approach is different in that it considers these doubly periodic surfaces by using geometric function theory techniques and the shearing of analytic

Received by the editors on July 31, 2002, and in revised form on October 11, 2002.

functions. Finally, by considering the family of conjugate surfaces, we also derive a one-parameter family of surfaces that transforms Scherk's saddle tower, or singly periodic, surface into the catenoid.

2. Shearing elliptic integrals. First we need a definition.

Definition 1. A domain Ω is convex in the direction $e^{i\varphi}$ if, for every $a \in \mathbf{C}$, the set

$$\Omega \cap \{a + te^{i\varphi} : t \in \mathbf{R}\}$$

is either connected or empty. In particular, a domain is convex in the direction of the real axis if every line parallel to the real axis has a connected intersection with Ω .

The shearing method is based upon a theorem by Clunie and Sheil-Small [2]:

Theorem A. *A harmonic function $f = h + \bar{g}$ locally univalent in \mathbf{D} is a univalent mapping of \mathbf{D} onto a domain convex in the direction of the real axis if and only if $h - g$ is an analytic univalent mapping of \mathbf{D} onto a domain convex in the direction of the real axis.*

We apply this method to shear elliptic integrals. Recall that an elliptic integral is the inverse of an elliptic, or doubly-periodic, function and can be thought of as a generalization of inverse trigonometric functions, see [11] or [13]. Elliptic functions have been used to construct periodic minimal surfaces [16]. There are three types of elliptic integrals, known as the elliptic integrals of the first, second and third kind. These can be represented in the following forms, respectively:

$$\begin{aligned} F(z, k) &= \int_0^z \frac{d\zeta}{\sqrt{(1-\zeta^2)(1-k^2\zeta^2)}}; \\ E(z, k) &= \int_0^z \sqrt{\frac{1-k^2\zeta^2}{1-\zeta^2}} d\zeta; \\ \Pi(z, m, k) &= \int_0^z \frac{d\zeta}{(1-m\zeta^2)\sqrt{(1-\zeta^2)(1-k^2\zeta^2)}}, \end{aligned}$$

where $k, m \in \overline{\mathbf{D}}$.

2.1 Elliptic integral of the first kind $F(z, k)$.

Lemma 2. *For $|k| \leq 1$, $F(z)$ maps \mathbf{D} univalently onto a convex region.*

Proof. Notice that

$$zF'(z) = \frac{z}{(1 - z^2)^{1/2}(1 - k^2z^2)^{1/2}}$$

maps \mathbf{D} onto \mathbf{C} minus four slits that lie on rays emanating from the origin. That is, $zF'(z)$ is a star-like mapping. Hence, by Alexander’s theorem, see [6], F is a convex mapping. \square

We can apply Clunie and Sheil-Small shearing technique to the elliptic integral F . Let $h(z) - g(z) = F(z, k)$ and $g'(z) = m^2z^2h'(z)$, where $|m| \leq 1$. Then we can write h and g in terms of the elliptic integrals F and Π . In particular,

$$\begin{aligned} h(z) &= \int_0^z \frac{d\zeta}{(1 - m^2\zeta^2)\sqrt{(1 - \zeta^2)(1 - k^2\zeta^2)}} \\ &= \Pi(z, m^2, \text{csgn}(k) \cdot k) \\ g(z) &= \int_0^z \frac{m^2\zeta^2 d\zeta}{(1 - m^2\zeta^2)\sqrt{(1 - \zeta^2)(1 - k^2\zeta^2)}} \\ &= \Pi(z, m^2, \text{csgn}(k) \cdot k) - F(z, \text{csgn}(k) \cdot k), \end{aligned} \tag{1}$$

where the csgn function is used to determine in which half-plane k lies, that is,

$$\text{csgn}(k) = \begin{cases} 1 & \text{if } \text{Re}(k) > 0 \text{ or } \text{Re}(k) = 0 \text{ and } \text{Im}(k) > 0 \\ -1 & \text{if } \text{Re}(k) < 0 \text{ or } \text{Re}(k) = 0 \text{ and } \text{Im}(k) < 0. \end{cases}$$

Although we know that $F(\mathbf{D})$ is convex, we do not know much about $f(\mathbf{D})$ except that it is convex in the direction of the real axis, see Figure 1. However, there is a particular case in which we can make some interesting claims.

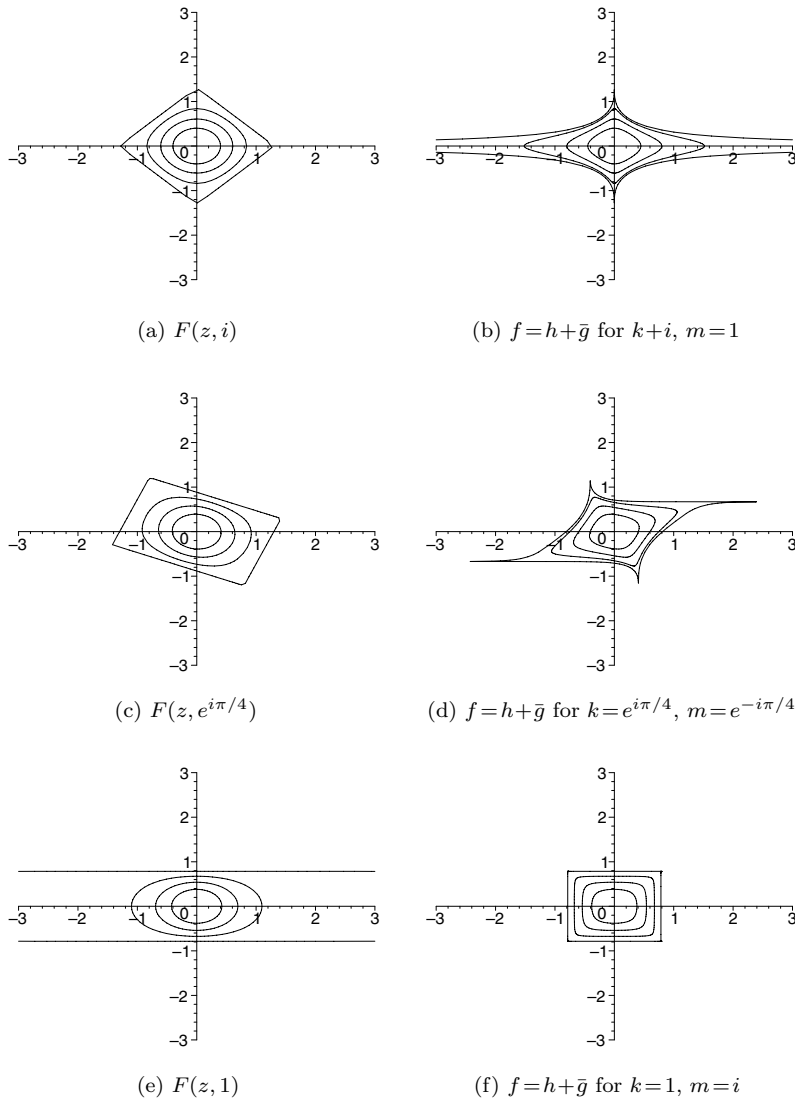

FIGURE 1. Images of concentric circles in \mathbf{D} under $F(z, k)$ and its harmonic shear, $f = h + \bar{g}$, where h and g are given by (1), for various values of k and m .

Special case. Consider the case $k = 1$. Then

$$F(z, 1) = \tanh^{-1} z = \frac{1}{2} \log \left(\frac{1+z}{1-z} \right),$$

which maps \mathbf{D} onto a horizontal strip and

$$\begin{aligned} h(z) &= \int_0^z \frac{d\zeta}{(1-m^2\zeta^2)(1-\zeta^2)} = \frac{1}{2(1-m^2)} \log \left(\frac{1+z}{1-z} \right) \\ &\quad + \frac{m}{2(m^2-1)} \log \left(\frac{1+mz}{1-mz} \right) \\ g(z) &= \int_0^z \frac{m^2\zeta^2 d\zeta}{(1-m^2\zeta^2)(1-\zeta^2)} = \frac{m^2}{2(1-m^2)} \log \left(\frac{1+z}{1-z} \right) \\ &\quad + \frac{m}{2(m^2-1)} \log \left(\frac{1+mz}{1-mz} \right). \end{aligned}$$

Proposition 3. For $k = 1$ and every m such that $|m| = 1$, the image of \mathbf{D} under $f = h + \bar{g}$ is a parallelogram for all $|m| = 1$.

Proof. First we will show that the image of \mathbf{D} is convex. By a result by Clunie and Sheil-Small [2, Theorem 5.7] it is equivalent to prove that the function

$$\begin{aligned} F(z) &= h(z) - e^{2i\varphi} g(z) \\ &= \frac{1 - e^{2i\varphi} m^2}{2(1 - m^2)} \log \left(\frac{1+z}{1-z} \right) - \frac{(1 - e^{2i\varphi})}{2(1 - m^2)} \log \left(\frac{1+mz}{1-mz} \right) \end{aligned}$$

is convex in the direction $e^{i\varphi}$ for all $\varphi \in [0, \pi)$. This can be done by showing that

$$(2) \quad \operatorname{Re} \{ e^{i\alpha} (1 - xz)(1 - yz) F'(z) \} > 0$$

for some $\alpha \in \mathbf{R}$ and $x, y \in \partial\mathbf{D}$, see [10, 14]. Let $\alpha = \frac{\pi}{2} - \varphi$ and $-x = y = 1$. Then

$$H(z) = e^{i\alpha} (1 - xz)(1 - yz) F'(z) = ie^{-i\varphi} \frac{1 - e^{2i\varphi} m^2 z^2}{1 - m^2 z^2}.$$

Since Möbius transformation $(1 - e^{2i\varphi}m^2z^2)/(1 - m^2z^2)$ maps \mathbf{D} onto the right half-plane, we have that $\operatorname{Re}\{H(z)\} > 0$ for all $z \in \mathbf{D}$ and the image of \mathbf{D} under $f = h + \bar{g}$ is convex.

Second the boundary of the \mathbf{D} gets mapped to the four points under f . This is because with $m = e^{i\theta}$, without loss of generality, assume $\theta \in (0, \pi)$, and $z = e^{i\varphi}$, we have

$$\begin{aligned} \operatorname{Re}\{f(z)\} &= \frac{1}{2\sin\theta} \left[\arg\left(i \cot\left(\frac{\theta + \varphi}{2}\right)\right) - \cos\theta \arg\left(i \cot\frac{\varphi}{2}\right) \right] \\ &= \begin{cases} \pi(1 + \cos\theta)/4\sin\theta & \text{if } \varphi \in (-\theta, 0), \\ \pi(1 - \cos\theta)/4\sin\theta & \text{if } \varphi \in (0, \pi - \theta), \\ -\pi(1 + \cos\theta)/4\sin\theta & \text{if } \varphi \in (\pi - \theta, \pi), \\ -\pi(1 - \cos\theta)/4\sin\theta & \text{if } \varphi \in (\pi, 2\pi - \theta), \end{cases} \end{aligned}$$

and

$$\operatorname{Im}\{f(z)\} = \frac{1}{2} \arg\left(i \cot\frac{\varphi}{2}\right) = \begin{cases} \pi/4 & \text{if } \varphi \in (0, \pi), \\ -\pi/4 & \text{if } \varphi \in (\pi, 2\pi). \end{cases}$$

Finally, Bshouty and Hengartner, see [1, Remark 3.4], note that in this case the image of \mathbf{D} under f must be the convex polygon. That is, the image of \mathbf{D} under f is a parallelogram. \square

The images of \mathbf{D} under $f = h + \bar{g}$ for $m = e^{i\pi/2}$, $m = e^{i\pi/4}$ and $m = e^{i\pi/6}$ are shown in Figure 1(f) and Figure 2(a),(b).

2.2 Elliptic integral of the second kind $E(z, k)$.

Lemma 4. *For $k = e^{i\theta}$, E maps \mathbf{D} univalently onto a region convex in the direction $e^{i\pi/2}$.*

Proof. Note that $E(z, k)$ is convex in the direction $e^{i\beta}$, if

$$\operatorname{Re}\{E'(z, k)(1 + ze^{i(\alpha+\beta)})(1 + ze^{-i(\alpha-\beta)})\} > 0,$$

for some $\alpha \in \mathbf{R}$, see [10, 14]. Applying this to our claim with $\alpha, \beta = \pi/2$, we have

$$\operatorname{Re}\{E'(z, e^{i\theta})(1 - z^2)\} = \operatorname{Re}\{\sqrt{1 - e^{2i\theta}z}\sqrt{1 - z^2}\}.$$

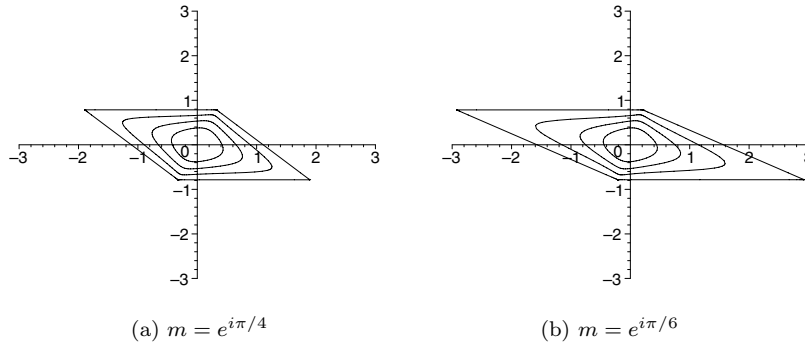

FIGURE 2. Images of concentric circles in \mathbf{D} under the harmonic shear of $F(z, 1)$ for various values of m .

Notice that $\operatorname{Re}\{1 - e^{2i\theta}z\} > 0$ for all $\theta \in \mathbf{R}$, where $z \in \mathbf{D}$. Hence, $\operatorname{Re}\{\sqrt{1 - e^{2i\theta}z}\sqrt{1 - z^2}\} > 0$, see [7, p. 79, Theorem 2 (11)]. \square

Clunie and Sheil-Small’s shearing technique applied to a function, f , convex in the direction $e^{i\pi/2}$ requires us to consider $h+g = f$. Applying this to our situation, let $k = e^{i\theta}$. Then for the elliptic integral E , let $h + g = E$ and $g' = -k^2z^2h'$. By doing so, we can solve for h and g in terms of the elliptic integrals F and E .

$$h(z) = \int_0^z \frac{d\zeta}{\sqrt{(1 - k^2\zeta^2)(1 - \zeta^2)}} = F(z, \operatorname{csgn}(k) \cdot k)$$

$$g(z) = \int_0^z \frac{-k^2\zeta^2 d\zeta}{\sqrt{(1 - k^2\zeta^2)(1 - \zeta^2)}} = E(z, \operatorname{csgn}(k) \cdot k) - F(z, \operatorname{csgn}(k) \cdot k).$$

Again, we do not know much about $f(\mathbf{D})$ except that it is convex in the direction of the imaginary axis, see Figure 3.

3. Minimal surfaces from harmonic univalent mappings.

There is a nice relationship between embedded, i.e., nonself-intersecting, minimal surfaces and univalent harmonic mappings. In the theory of minimal surfaces, the Weierstrass-Enneper representation provides a formula for the local representation of a minimal surface, see [3].

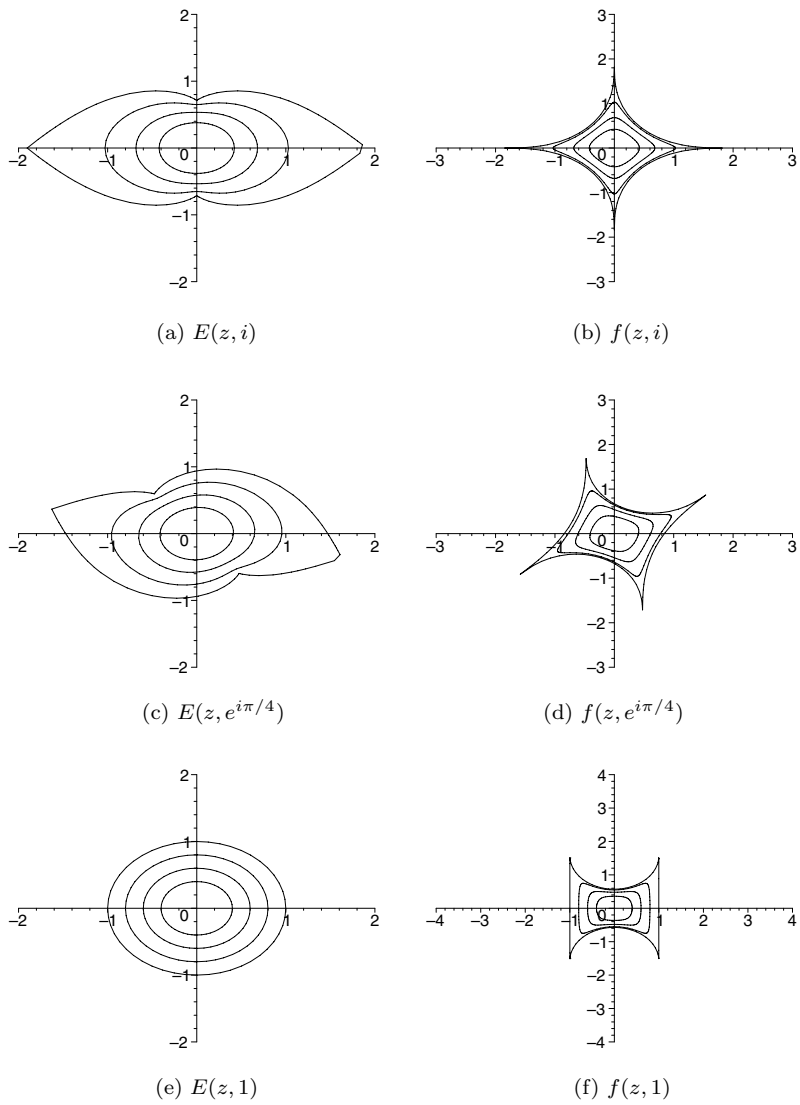

FIGURE 3. Images of concentric circles in \mathbf{D} under $E(z, k)$ and its harmonic shear for various values of k .

Theorem B. *For every analytic function μ and meromorphic function ν in \mathbf{D} with $\mu \neq 0$, $\nu \neq 0$ such that $\mu\nu^2$ is analytic in \mathbf{D} , the parametrization $X(z) = (x_1(z), x_2(z), x_3(z))$ defines a minimal surface $X : \mathbf{D} \rightarrow \mathbf{R}^3$, where*

$$\begin{aligned} x_1(z) &= \operatorname{Re} \int_0^z \mu(1 - \nu^2) d\zeta, \\ x_2(z) &= \operatorname{Re} \int_0^z i\mu(1 + \nu^2) d\zeta, \\ x_3(z) &= \operatorname{Re} \int_0^z 2\mu\nu d\zeta. \end{aligned}$$

Using this, we can construct embedded minimal surfaces by lifting harmonic univalent mappings, see [8]. Some papers have already investigated the family of minimal surfaces resulting from lifting specific mappings [4, 5].

For our purposes, notice that x_1, x_2, x_3 can be written in terms of h and g , where $f = h + \bar{g}$ is a univalent harmonic mapping. In particular, $h = \int \mu d\zeta$ and $g = -\int \mu\nu^2 d\zeta$. Thus,

$$\begin{aligned} x_1(z) &= \operatorname{Re} \{h(z) + g(z)\} = \operatorname{Re} \{f(z)\}, \\ x_2(z) &= \operatorname{Im} \{h(z) - g(z)\} = \operatorname{Im} \{f(z)\}, \\ x_3(z) &= 2\operatorname{Im} \left\{ \int_0^z \sqrt{h'(\zeta)g'(\zeta)} dz \right\}. \end{aligned}$$

For example, using the shear of the elliptic integral of the first kind,

$$x_3(z) = \int_0^z \frac{m\zeta d\zeta}{(1 - m^2\zeta^2)\sqrt{(1 - \zeta^2)(1 - k^2\zeta^2)}},$$

while for the shear of the elliptic integral of the second kind, we get

$$x_3(z) = \int_0^z \frac{ik\zeta d\zeta}{\sqrt{(1 - k^2\zeta^2)(1 - \zeta^2)}}.$$

Images of some minimal surfaces generated by the shearing of these two kinds of elliptic integrals are shown in Figure 4, for projections onto the complex plane, see Figure 1(b) and Figure 3(d).

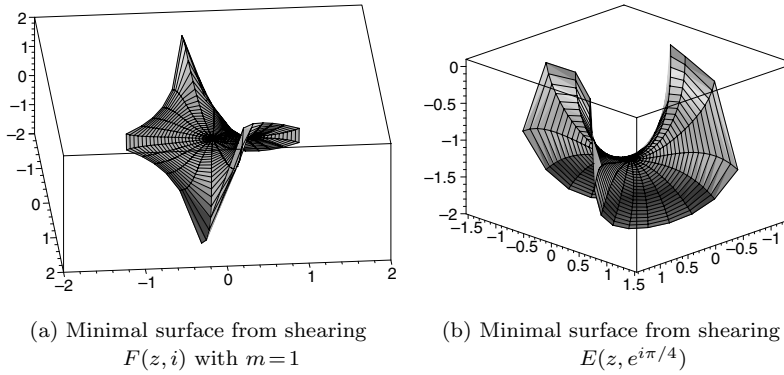

FIGURE 4. The minimal surface generated by the shear of various elliptic integrals.

Special case. Consider the case of the minimal surfaces constructed from shearing the elliptic integral of the first kind with $k = 1$ while letting m vary. This is particularly interesting, because they form a one-parameter family of slanted Scherk surfaces that range from the canonical Scherk first surface to the helicoid. Recall that when we shear the elliptic integral $F(z, 1)$, we have $f(z) = h(z) + \overline{g(z)}$, where

$$\begin{aligned}
 h(z) &= \frac{1}{2(1-m^2)} \log\left(\frac{1+z}{1-z}\right) + \frac{m}{2(m^2-1)} \log\left(\frac{1+mz}{1-mz}\right) \\
 g(z) &= \frac{m^2}{2(1-m^2)} \log\left(\frac{1+z}{1-z}\right) + \frac{m}{2(m^2-1)} \log\left(\frac{1+mz}{1-mz}\right).
 \end{aligned}$$

Notice that

$$x_3 = \text{Im} \left\{ \frac{m}{1-m^2} \log\left(\frac{1-m^2z^2}{1-z^2}\right) \right\}.$$

For $m = i$ the resulting minimal surface has the form

$$\begin{aligned}
 X &= (x_1, x_2, x_3) \\
 &= \left(\text{Re} \left\{ -\frac{i}{2} \log\left(\frac{1+iz}{1-iz}\right) \right\}, \text{Re} \left\{ -\frac{i}{2} \log\left(\frac{1+z}{1-z}\right) \right\}, \right. \\
 &\quad \left. \text{Re} \left\{ \frac{1}{2} \log\left(\frac{1+z^2}{1-z^2}\right) \right\} \right),
 \end{aligned}$$

which is Scherk’s first, or doubly periodic, surface. With $m = e^{i\theta}$ and letting θ decrease between $\pi/2$ and 0, we get sheared transformations of Scherk’s first surface. In the limit, i.e., $\theta = 0$, we have the equation

$$\begin{aligned} X &= (x_1, x_2, x_3) \\ &= \left(\operatorname{Re} \left\{ \frac{z}{1-z^2} \right\}, \operatorname{Re} \left\{ -\frac{i}{2} \log \left(\frac{1+z}{1-z} \right) \right\}, \operatorname{Re} \left\{ \frac{-iz^2}{1-z^2} \right\} \right). \end{aligned}$$

Using the substitution $z \mapsto e^z - 1/e^z + 1$ and the fact that $\operatorname{Re} \{-iz^2/1-z^2\} = \operatorname{Re} \{(1/2i)(1+z^2/1-z^2)\}$, this equation is equivalent to

$$X = (x_1, x_2, x_3) = \left(\frac{1}{2} \sinh u \cos v, \frac{1}{2}v, \frac{1}{2} \sinh u \sin v \right),$$

which is an equation of a helicoid.

The Schwarz reflection principle allows one to create larger periodic minimal surfaces by reflecting a known surface through lines and planes of symmetry. This technique is used widely today to create many new minimal surfaces. The reflection principle states, see [3]:

Theorem C. (1) *Every straight line contained in a minimal surface is an axis of symmetry of the surface.*

(2) *If a minimal surface intersects some plane E perpendicularly, then E is a plane of symmetry of the surface.*

From Proposition 3, we know that the projection of these minimal surfaces formed by shearing the elliptic integral of the first kind with $k = 1$ onto the complex plane is a parallelogram. Hence we can apply the Schwarz reflection principle to combine one of these minimal surfaces with copies of itself to form a checkerboard-like conglomeration of minimal surfaces, see Figure 5.

From these slanted Scherk’s first surface we can construct another one-parameter family of surfaces which this time varies from Scherk’s saddle tower, or singly periodic, surface to the catenoid. To do this, we use the idea of conjugate surfaces.

Definition 5. If a minimal surface $X(u, v) = (x_1(u, v), x_2(u, v), x_3(u, v))$ is defined on a simply connected domain $\Omega \in \mathbf{C}$, then we define the

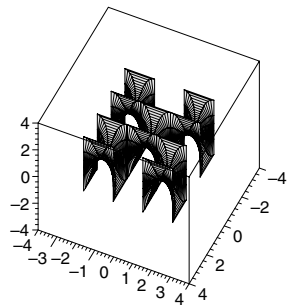

(a) Five pieces of Scherk's First Surface ($m = e^{i\pi/2}$)

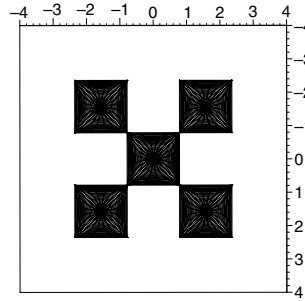

(b) Projection of (a) onto xy -plane

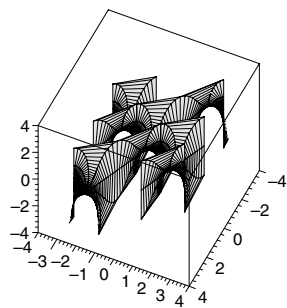

(c) Five pieces of Scherk's Slanted Surface ($m = e^{i\pi/4}$)

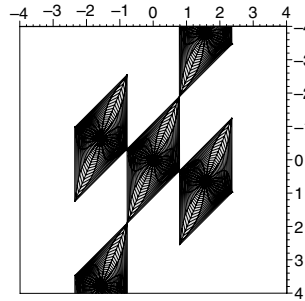

(d) Projection of (c) onto xy -plane

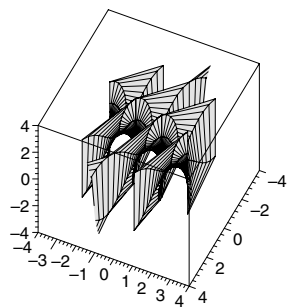

(e) Five pieces of Scherk's Slanted Surface ($m = e^{i\pi/6}$)

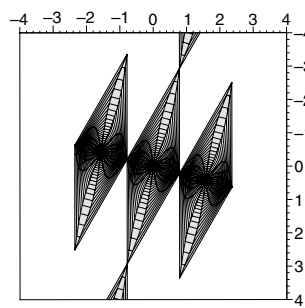

(f) Projection of (e) onto xy -plane

FIGURE 5. The minimal surface generated by the shearing of the elliptic integral $F(z, 1)$.

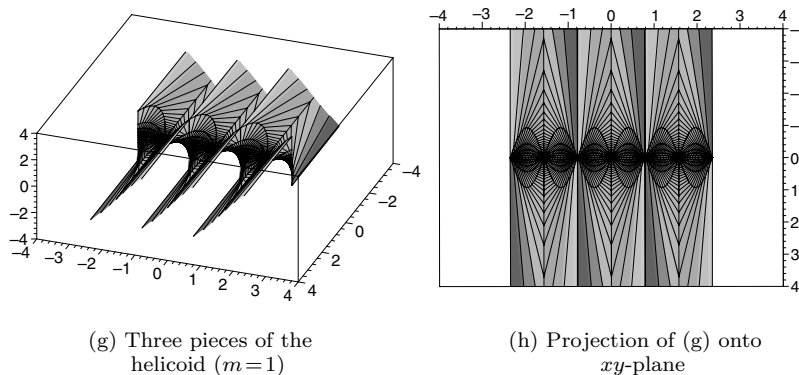

FIGURE 5. The minimal surface generated by the shearing of the elliptic integral $F(z, 1)$.

conjugate, or adjoint, surface, $X^*(u, v) = (x_1^*(u, v), x_2^*(u, v), x_3^*(u, v))$ to $Z(u, v)$ on Ω as solution of the Cauchy-Riemann equations

$$X_u = X_v^*, \quad X_v = -X_u^*$$

in Ω .

Scherk's saddle tower is the conjugate surface to Scherk's first surface and the catenoid is the conjugate surface to the helicoid [3].

For our purposes, notice that

$$\begin{aligned} x_1^*(z) &= \operatorname{Re} \{h(z) - g(z)\}, \\ x_2^*(z) &= \operatorname{Im} \{h(z) + g(z)\}, \\ x_3^*(z) &= 2\operatorname{Re} \left\{ \int_0^z \sqrt{h'(\zeta)g'(\zeta)} d\zeta \right\}. \end{aligned}$$

In the minimal surface generated by the shearing of the elliptic integral $F(z, 1)$, each lattice is composed of a principal part that is a minimal graph over a convex domain. Krust theorem, see [3], states that in such a situation, the conjugate surface will be a minimal graph. Thus, for each $m = e^{i\theta}$ with θ varying from $\pi/2$ to 0, we have a one-parameter family of Scherk saddle tower-like surfaces. The standard Scherk saddle tower surface occurs for $\theta = \pi/2$. As θ decreases, the holes in one side elongate while the holes on the neighboring side shorten and in the limit form the catenoid.

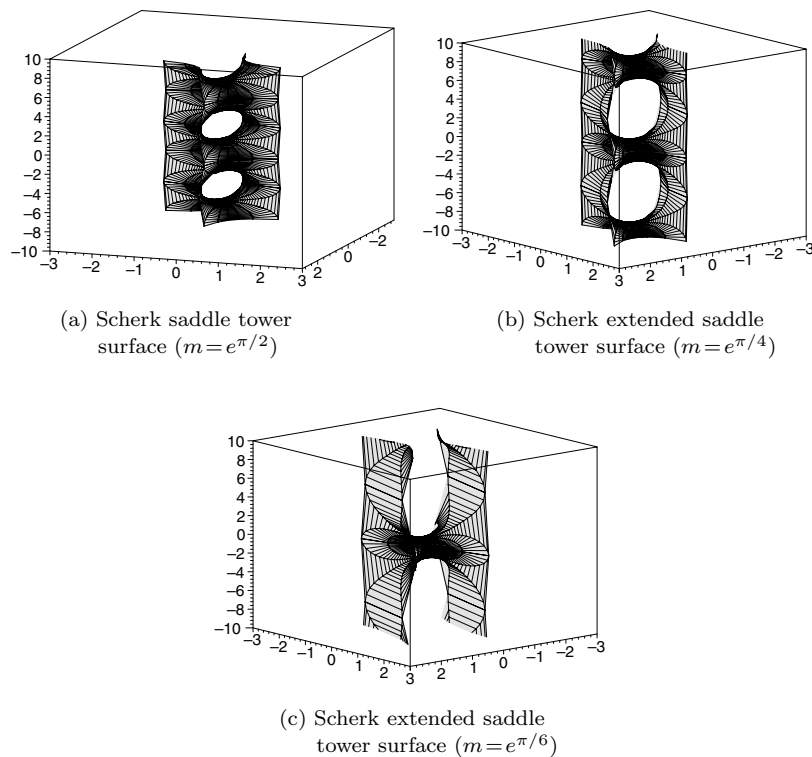

FIGURE 6. The conjugate minimal surface generated by the shearing of the elliptic integral $F(z, 1)$.

REFERENCES

1. D. Bshouty and W. Hengartner, *Boundary values versus dilatations of harmonic mappings*, J. Anal. Math. **72** (1997), 141–164.
2. J. Clunie and T. Sheil-Small, *Harmonic univalent functions*, Ann. Acad. Sci. Fenn. Ser. A.I Math. **9** (1984), 3–25.
3. U. Dierkes, S. Hildebrandt, A. Küster and O. Wohlrab, *Minimal surfaces I*, Springer-Verlag, Berlin, 1992.
4. K. Driver and P. Duren, *Harmonic shears of regular polygons by hypergeometric functions*, J. Math. Anal. Appl. **239** (1999), 72–84.
5. P. Duren and W. Thygeson, *Harmonic mappings related to Scherk's saddle-tower minimal surfaces*, Rocky Mountain J. Math. **30** (2000), 555–564.

6. P. Duren, *Univalent functions*, Springer-Verlag, New York, 1983.
7. A.W. Goodman, *Univalent functions*, Vol. 1, Mariner Publ. Co., Inc., Tampa, Florida, 1983.
8. W. Hengartner and G. Schober, *Curvature estimates for some minimal surfaces*, in *Complex analysis*, Birkhäuser, Basel, 1988, pp. 87–100.
9. H. Lazard-Holly and W.H. Meeks III, *Classification of doubly-periodic minimal surfaces of genus zero*, *Invent. Math.* **143** (2001), 1–27.
10. W. Koepf, *Parallel accessible domains and domains that are convex in some direction*, in *Partial differential equations with complex analysis*, Pitman Res. Notes Math. Ser., vol. 262, Longman Sci. Technical, Harlow, 1992, pp. 93–105.
11. H. McKean and V. Moll, *Elliptic curves: Function theory, geometry, arithmetic*, Cambridge Univ. Press, Cambridge, 1999.
12. W.H. Meeks III and H. Rosenberg, *The global theory of doubly periodic minimal surfaces*, *Invent. Math.* **97** (1989), 351–379.
13. Z. Nehari, *Conformal mapping*, Dover Publ., Inc., New York, 1975.
14. W.C. Royster and M. Ziegler, *Univalent functions convex in one direction*, *Publ. Math. Debrecen.* **23** (1976), 339–345.
15. L. Schaubroeck, *Growth, distortion and coefficient bounds for plane harmonic mappings convex in one direction*, *Rocky Mountain J. Math.* **31** (2001), 625–639.
16. M. Weber and M. Wolf, *Minimal surfaces of least total curvature and moduli spaces of plane polygonal arcs*, *Geom. Funct. Anal.* **8** (1998), 1129–1179.
17. F. Wei, *Some existence and uniqueness theorems for doubly periodic minimal surfaces*, *Invent. Math.* **109** (1992), 113–136.

DEPARTMENT OF MATHEMATICS, BRIGHAM YOUNG UNIVERSITY, PROVO, UT 84602

E-mail address: mdorff@math.byu.edu

DEPARTMENT OF APPLIED MATHEMATICS, FACULTY OF ECONOMICS, MARIA CURIE-SKŁODOWSKA UNIVERSITY, 20-031 LUBLIN, POLAND

E-mail address: jsszynal@golem.umcs.lublin.pl