

# Generic flows on 3-manifolds

Carlo Petronio

---

**Abstract** A 3-dimensional *generic flow* is a pair  $(M, v)$  with  $M$  a smooth compact oriented 3-manifold and  $v$  a smooth nowhere-zero vector field on  $M$  having generic behavior along  $\partial M$ ; on the set of such pairs we consider the equivalence relation generated by topological equivalence (homeomorphism mapping oriented orbits to oriented orbits) and by homotopy with fixed configuration on the boundary, and we denote by  $\mathcal{F}$  the quotient set. In this paper we provide a combinatorial presentation of  $\mathcal{F}$ . To do so we introduce a certain class  $\mathcal{S}$  of finite 2-dimensional polyhedra with extra combinatorial structures, and some moves on  $\mathcal{S}$ , exhibiting a surjection  $\varphi : \mathcal{S} \rightarrow \mathcal{F}$  such that  $\varphi(P_0) = \varphi(P_1)$  if and only if  $P_0$  and  $P_1$  are related by the moves. To obtain this result we first consider the subset  $\mathcal{F}_0$  of  $\mathcal{F}$  consisting of flows having all orbits homeomorphic to closed segments or points, constructing a combinatorial counterpart  $\mathcal{S}_0$  for  $\mathcal{F}_0$ , and then adapting it to  $\mathcal{F}$ .

Combinatorial presentations of 3-dimensional topological categories, such as the description of closed oriented 3-manifolds via surgery along framed links in  $S^3$ , and many more, have proved crucial for the theory of quantum invariants, initiated in [10] and [13] and now one of the main themes of geometric topology. In this paper we provide one such presentation for the set  $\mathcal{F}$  of pairs  $(M, v)$  with  $M$  a smooth 3-manifold and  $v$  a smooth flow having generic behavior on  $\partial M$ , viewed up to homotopy with fixed configuration on  $\partial M$ . This extends the presentation of closed combed 3-manifolds contained in [5], and it is based on a generalization of the notion of *branched spine*, introduced there as a combination of the definition of special spine due to Matveev [8] with the concept of branched surface introduced by Williams [14], already partially investigated by Ishii [7] and Christy [6]. A *presentation* here is, as usual, meant as a constructive surjection onto  $\mathcal{F}$  from a set of finite combinatorial objects, together with a finite set of combinatorial moves on the objects generating the equivalence relation induced by the surjection.

To get our presentation we will initially restrict to generic flows having all orbits homeomorphic to points or to segments, viewed first up to topological equivalence (homeomorphism mapping oriented orbits to oriented orbits, see [11, Section 4.7 and p. 115]) and then up to homotopy through flows having all orbits homeomorphic to points or to segments, and we will carefully describe their combinatorial counterparts.

A restricted type of generic flows on manifolds with boundary was actually already considered in [5], but two such flows could never be glued together along boundary components. On the contrary, as we will point out in detail in Remark 3.4, using the flows we consider here one can develop a theory of cobordism and hence, hopefully, a topological quantum field theory (TQFT) in the spirit of [12]. Another reason why we expect that our encoding of generic flows might have nontrivial applications is that the notion of branched spine was one of the combinatorial tools underlying the theory of quantum hyperbolic invariants of Baseilhac and Benedetti [1]–[3].

## 1. Generic flows, streams, and stream spines

In this section we define the topological objects that we will deal with in the paper and we introduce the combinatorial objects that we will use to encode them. We then describe our first representation result, for manifolds with generic traversing flows (which we call *streams*) viewed up to topological equivalence (homeomorphism mapping oriented orbits to oriented orbits).

### 1.1. Generic flows

Let  $M$  be a smooth, compact, and oriented 3-manifold with nonempty boundary, and let  $v$  be a vector field on  $M$ . We will always assume in this paper that  $v$  is smooth and nowhere vanishing. We also stipulate the following genericity of the tangency of  $v$  to  $\partial M$ , first discussed by Morin [9].

- (G1) – The field  $v$  is tangent to  $\partial M$  only along a union  $\Gamma$  of circles.  
 – Each component of  $\Gamma$  separates a region on which  $v$  points inside  $M$  from a region on which  $v$  points outside  $M$ .  
 – The field  $v$  is tangent to  $\Gamma$  at isolated points only.  
 – At the two sides on  $\Gamma$  of each tangency point of  $v$  to  $\Gamma$ , one has that  $v$  is directed to opposite sides of  $\Gamma$  on  $\partial M$ .

We now graphically illustrate all the local configurations compatible with this genericity condition, and at the same time we introduce some terminology that we will repeatedly employ in the rest of the paper. The models are viewed up to topological equivalence (see [11]; analytic descriptions of these local models and a hint toward a formal proof that there are no other models is provided below).

- We call *in-region* (resp., *out-region*) the union of the components of  $(\partial M) \setminus \Gamma$  on which  $v$  points towards the interior (resp., the exterior) of  $M$ ;
- If  $A$  is a point of  $\Gamma$  we will say that  $A$  is *concave* if at  $A$  the field  $v$  points from the out-region to the in-region and *convex* if it points from the in-region to the out-region; this terminology is borrowed from [5] and is motivated by the shape of the orbits of  $v$  near  $A$  (see Figure 1).
- A point  $A$  of  $\Gamma$  at which  $v$  is tangent to  $\Gamma$  will be termed the *transition*

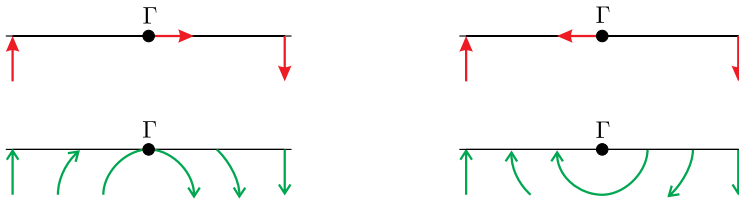

Figure 1. Orbits of  $v$  near a concave (left) and near a convex (right) point of  $\Gamma$ . All pictures represent a cross section transverse to  $\Gamma$ . The top pictures show  $v$ ; the bottom ones show its orbits.

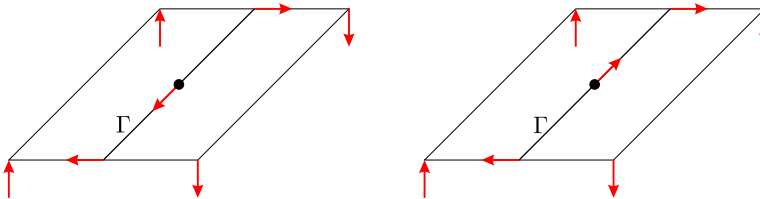

Figure 2. Types of transition points: on the left  $v$  points from the concave to the convex portion of  $\Gamma$ ; on the right  $v$  points from the convex to the concave portion of  $\Gamma$ ; note that mirror images in 3-space of these configurations should also be taken into account (namely, the figures are unoriented).

point and, more exactly, a *convex-to-concave* or a *concave-to-convex* transition point, depending on the direction of  $v$  at  $A$  (see Figure 2).

The next result records obvious facts and two less obvious ones.

PROPOSITION 1.1

Let  $A$  be a point of  $\partial M$ . Then, depending on where  $A$  lies, the orbit of  $v$  through  $A$  extends as shown in Table 1.

Table 1

$A$ in the in-region	only forward
$A$ in the out-region	only backward
$A$ a concave point	both forward and backward
$A$ a convex point	neither forward nor backward
$A$ a concave-to-convex transition point	only backward
$A$ a convex-to-concave transition point	only forward

*Proof*

The result is evident except for orbits through the transition points. To deal with them we first analyze what the orbits would be if  $v$  were projected to  $\partial M$ , which we do in Figure 3. The picture shows that at the concave-to-convex transition points the orbit of the projection of  $v$  lies in the out-region, which implies that

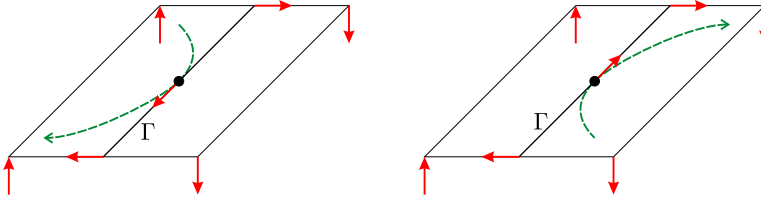

Figure 3. Orbits through the transition points for the field obtained by projecting  $v$  to a vector field tangent to  $\partial M$ .

the orbit of  $v$  extends backward but not forward, while at the convex-to-concave transition points the opposite happens.  $\square$

From now on an orbit of  $v$  reaching a concave-to-convex transition point or leaving from a convex-to-concave transition point will be termed *transition orbit*.

## 1.2. Explicit local models

For the sake of completeness we provide here explicit local models for a vector field  $v$  on a manifold  $M$  satisfying the genericity condition (G1), and we prove that these models are essentially unique.

We begin by assuming that near a boundary point  $A$  the manifold  $M$  is identified with  $(-1, 1) \times (-1, 1) \times (-1, 0] \subset \mathbb{R}^3$ , so  $\partial M$  is locally  $(-1, 1) \times (-1, 1) \times \{0\}$ , with  $A$  corresponding to the origin. For  $A$  in the out-region or in the in-region we take the constant fields  $v = \begin{pmatrix} 0 \\ 0 \\ 1 \end{pmatrix}$  and  $v = \begin{pmatrix} 0 \\ 0 \\ -1 \end{pmatrix}$ , respectively. For  $A$  a concave, convex, or transition point we assume that  $\Gamma$  is locally  $(-1, 1) \times \{0\} \times \{0\}$ , and we take the following:

- for  $A$  a concave tangency point,  $v_{cc} \begin{pmatrix} x \\ y \\ z \end{pmatrix} = \begin{pmatrix} 0 \\ 1-y^2 \\ -y \end{pmatrix}$ ;
- for  $A$  a convex tangency point,  $v_{cv} \begin{pmatrix} x \\ y \\ z \end{pmatrix} = \begin{pmatrix} 0 \\ y^2-1 \\ -y \end{pmatrix}$ ;
- for  $A$  a convex-to-concave transition point,

$$v_{cv \rightarrow cc} \begin{pmatrix} x \\ y \\ z \end{pmatrix} = \begin{pmatrix} (1-x^2)(1-y^2) \\ x(1-y^2) \\ -y \end{pmatrix};$$

- for  $A$  a concave-to-convex transition point,

$$v_{cc \rightarrow cv} \begin{pmatrix} x \\ y \\ z \end{pmatrix} = \begin{pmatrix} (1-x^2)(1-y^2) \\ x(y^2-1) \\ -y \end{pmatrix}.$$

The analytic expressions just provided correspond exactly to the pictures of the local models shown above. However, since only the behavior in a neighborhood

of 0 is relevant, we can also employ the following simpler vector fields:

$$\begin{aligned}\tilde{v}_{cc}\begin{pmatrix} x \\ y \\ z \end{pmatrix} &= \begin{pmatrix} 0 \\ 1 \\ -y \end{pmatrix}, & \tilde{v}_{cv}\begin{pmatrix} x \\ y \\ z \end{pmatrix} &= \begin{pmatrix} 0 \\ -1 \\ -y \end{pmatrix}, \\ \tilde{v}_{cv\rightarrow cc}\begin{pmatrix} x \\ y \\ z \end{pmatrix} &= \begin{pmatrix} 1 \\ x \\ -y \end{pmatrix}, & \tilde{v}_{cc\rightarrow cv}\begin{pmatrix} x \\ y \\ z \end{pmatrix} &= \begin{pmatrix} 1 \\ -x \\ -y \end{pmatrix}.\end{aligned}$$

One advantage of these alternative expressions is that one readily sees that they are generic up to perturbation within smooth vector fields: starting from a vector field  $v = (X, Y, Z)$  with  $Z(0) = 0$  one can choose coordinates and perturb  $v$  so that

- $\frac{\partial Z}{\partial x}(0) = 0$  and  $\frac{\partial Z}{\partial y}(0) < 0$ ;
- either  $Y(0) \neq 0$  (whence  $\tilde{v}_{cc}$  for  $Y(0) > 0$  and  $\tilde{v}_{cv}$  for  $Y(0) < 0$ ) or  $\frac{\partial Y}{\partial x}(0) \neq 0$  (whence  $\tilde{v}_{cv\rightarrow cc}$  for  $\frac{\partial Y}{\partial x}(0) > 0$  and  $\tilde{v}_{cc\rightarrow cv}$  for  $\frac{\partial Y}{\partial x}(0) < 0$ ).

Local models of an alternative nature are described by assuming that  $M$  is a portion of  $\mathbb{R}^3$  depending on the model, with  $A \in \partial M$  corresponding to the origin, while  $v$  is the constant vertical field  $\begin{pmatrix} 0 \\ 0 \\ 1 \end{pmatrix}$ . In this framework,

- $A$  is in the out-region for  $M = \{z \leq 0\}$ ;
- $A$  is in the in-region for  $M = \{z \geq 0\}$ ;
- $A$  is a concave tangency point for  $M = \{x \leq y^2\}$ ;
- $A$  is a convex tangency point for  $M = \{x \geq y^2\}$ ;
- $A$  is a convex-to-concave transition point for  $M = \{y \geq xz - z^3\}$ ;
- $A$  is a concave-to-convex transition point for  $M = \{y \leq xz - z^3\}$ .

We conclude this subsection by illustrating the proof of the uniqueness of the models up to topological equivalence. We do this explicitly for a concave or convex tangency point  $A$  (a similar argument applies to a transition point, but the details are more elaborate). In every case we assume that locally  $M$  is  $(-1, 1) \times (-1, 1) \times (-1, 0] \subset \mathbb{R}^3$ , with  $\Gamma = (-1, 1) \times \{0\} \times \{0\}$  and  $A$  the origin. We also take two smooth vector fields  $v_0$  and  $v_1$ , and we denote by  $\varphi_t^{(j)}(q)$  the point reached at time  $t$  by the flow generated by  $v_j$  with initial point  $q$ .

• If  $v_0$  and  $v_1$  turn  $\Gamma$  into a concave tangency line, then  $v_j(x, y, z)$  has vanishing third component and positive second component for  $y = z = 0$ , while it has third component concordant with  $-y$  for  $z = 0$  and  $y \neq 0$ . We now fix some arbitrary positive  $\delta < 1$  (e.g.,  $\delta = \frac{1}{2}$  would do); for small enough  $\varepsilon > 0$  we can define

$$\begin{aligned}U_\varepsilon^{(j)} &= \{\varphi_t^{(j)}(q) : q \in (-\delta, \delta) \times (-\delta, 0) \times \{0\}, -\varepsilon < t \leq 0\} \\ &\cup \{\varphi_t^{(j)}(q) : q \in (-\delta, \delta) \times \{0\} \times (-\delta, 0], -\varepsilon < t < \varepsilon\} \\ &\cup \{\varphi_t^{(j)}(q) : q \in (-\delta, \delta) \times (0, \delta) \times \{0\}, 0 \leq t < \varepsilon\},\end{aligned}$$

and we note the following:

- (A)  $U_\varepsilon^{(j)}$  is a neighborhood of  $A$ ;
- (B) Every point of  $U_\varepsilon^{(j)}$  has a unique expression  $\varphi_t^{(j)}(q)$  as in the definition.

We then get an orbit-preserving homeomorphism  $U_\varepsilon^{(0)} \rightarrow U_\varepsilon^{(1)}$  by mapping each  $\varphi_t^{(0)}(q)$  to  $\varphi_t^{(1)}(q)$ .

• Suppose instead that  $v_0$  and  $v_1$  turn  $\Gamma$  into a convex tangency line. Then  $v_j(x, y, z)$  has vanishing third component and negative second component for  $y = z = 0$ , while it has third component concordant with  $-y$  for  $z = 0$  and  $y \neq 0$ . We now choose a small enough  $\varepsilon > 0$  and for  $q \in (-\varepsilon, \varepsilon) \times (0, \varepsilon) \times \{0\}$  we denote by  $\tau_j(q)$  the smallest  $t > 0$  such that  $\varphi_t^{(j)}(q)$  belongs to  $(-1, 1) \times (-1, 0) \times \{0\}$ , noting that  $\tau_j$  extends as a continuous function on  $(-\varepsilon, \varepsilon) \times [0, \varepsilon) \times \{0\}$  if we set  $\tau_j(q) = 0$  on  $(-\varepsilon, \varepsilon) \times \{0\} \times \{0\}$ . We can now define

$$U_\varepsilon^{(j)} = \{q = \varphi_0^{(j)}(q) : q \in (-\varepsilon, \varepsilon) \times \{0\} \times \{0\}\} \cup \{\varphi_t^{(j)}(q) : q \in (-\varepsilon, \varepsilon) \times (0, \varepsilon) \times \{0\}, 0 \leq t \leq \tau_j(q)\}$$

and note that the above conditions (A) and (B) hold in this case too. We can then define an orbit-preserving homeomorphism  $U_\varepsilon^{(0)} \rightarrow U_\varepsilon^{(1)}$  by mapping each  $\varphi_t^{(0)}(q)$  to  $\varphi_{t \cdot \tau_1(q) / \tau_0(q)}^{(1)}(q)$ .

### 1.3. Streams

Our main aim in this paper is to provide a combinatorial presentation of the set of generic flows on 3-manifolds up to homotopy with fixed configuration on the boundary, but to achieve this aim we first need to somewhat restrict the class of flows we consider and the equivalence relation on them. Informally, we call a *stream* on a 3-manifold  $M$  a vector field  $v$  satisfying (G1) such that, in addition, all the orbits of  $v$  start and end on  $\partial M$ , and the orbits of  $v$  tangent to  $\partial M$  are generic with respect to each other. More precisely,  $v$  is a stream on  $M$  if it satisfies the conditions (G1)–(G4) defined as follows.

(G2) Every orbit of  $v$  is either a single point (a convex point of  $\Gamma$ ) or a closed arc with both ends on  $\partial M$ ;

(G3) The transition orbits are tangent to  $\partial M$  at their transition point only.

For the next and last condition we note that if an arc of an orbit of  $v$  has ends  $A$  and  $B$ , then the parallel transport along  $v$  defines a linear bijection from the tangent space to  $M$  at  $A$  to that at  $B$ . We then require the following.

(G4) Each orbit of  $v$  is tangent to  $\partial M$  at two points at most; if an orbit of  $v$  is tangent to  $\partial M$  at two points  $A$  and  $B$  that necessarily are concave points of  $\Gamma$  by conditions (G2) and (G3), then the tangent directions to  $\Gamma$  at  $A$  and at  $B$  are transverse to each other under the bijection defined by the parallel transport along  $v$ .

This last condition is illustrated in Figure 4. We will henceforth denote by

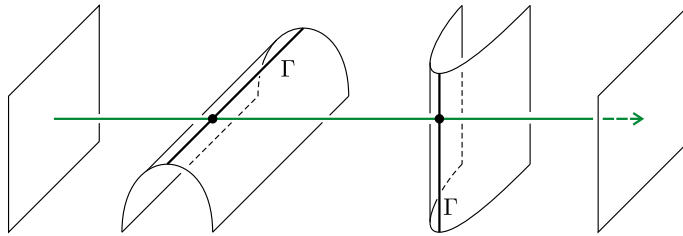

Figure 4. If an orbit of  $v$  is tangent to  $\partial M$  at two points of  $\Gamma$ , the two involved arcs of  $\Gamma$  are transverse to each other under the parallel transport along  $v$ .

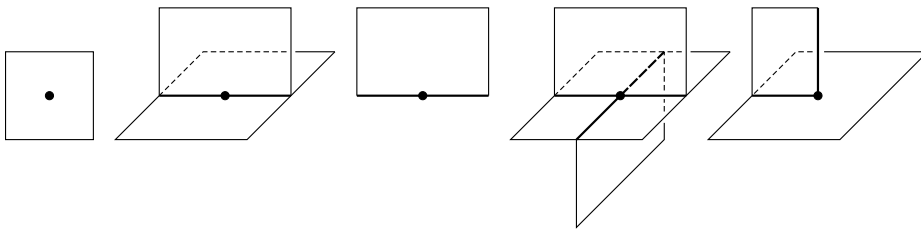

Figure 5. Local aspect of a stream spine.

$\mathcal{F}_0^*$  the set of pairs  $(M, v)$  with  $M$  an oriented, compact, connected 3-manifold and  $v$  a stream on  $M$ , up to topological equivalence.

### 1.4. Stream spines

We now introduce the objects that will eventually be shown to be the combinatorial counterparts of streams on smooth oriented 3-manifolds. As above, stating all the requirements takes some time and involves some new terminology. We will then stepwise introduce 3 conditions (S1), (S2), (S3) for a compact and connected 2-dimensional polyhedron  $P$ , the combination of which will constitute the definition of a *stream spine*. We begin with the following.

(S1) A neighborhood of each point of  $P$  is homeomorphic to one of the 5 models of Figure 5.

This condition implies that  $P$  consists of

- (1) some open surfaces, called *regions*, each having a closure in  $P$  which is a compact surface with possibly immersed boundary;
- (2) some *triple lines*, to which three regions are locally incident;
- (3) some *single lines*, to which only one region is locally incident;
- (4) a finite number of points, called *vertices*, to which six regions are locally incident;
- (5) a finite number of points, called *spikes*, to which both a triple and a single line are incident.

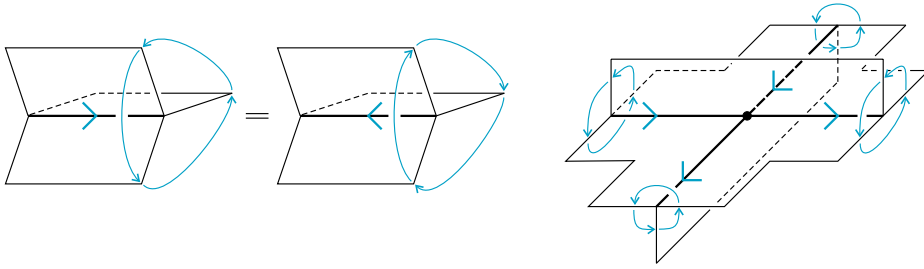

Figure 6. Screw orientation along a triple line and compatibility at vertices.

We note that a polyhedron satisfying condition (S1) is simple according to Matveev [8] but not almost special if single lines exist. Our next condition was first introduced in [4]; to state it we define a *screw orientation* along an arc of a triple line of  $P$  as an orientation of the arc together with a cyclic ordering of the three germs of regions of  $P$  incident to the arc, viewed up to simultaneous reversal of both, as in the left-hand side of Figure 6.

(S2) Along each triple line of  $P$  a screw-orientation is defined in such a way that at each vertex the screw-orientations are as in the right-hand side of Figure 6.

We now give the last condition of the definition of stream “spine.”

(S3) Each region of  $P$  is orientable, and it is endowed with a specific orientation, in such a way that no triple line is induced three times the same orientation by the regions incident to it.

We will say that two stream spines are *isomorphic* if they are related by a piecewise linear (PL) homeomorphism respecting the screw orientations along triple lines and the orientations of the regions, and we will denote by  $\mathcal{S}_0$  the set of all stream spines up to isomorphism.

### 1.5. Stream carried by a stream spine

In this subsection we will show that each stream spine uniquely defines an oriented smooth manifold and a stream on it. To begin we take a compact polyhedron  $P$  satisfying condition (S1) of the definition of stream-spine, namely locally appearing as in Figure 5. We will say that an embedding of  $P$  in a 3-manifold  $M$  is *branched* if the following happens upon identifying  $P$  with its image in  $M$  (see Figure 7).

- Each region of  $P$  has a well-defined tangent plane at every point.
- If a point  $A$  of  $P$  lies on a triple line but is neither a vertex nor a spike, the tangent planes at  $A$  to the 3 regions of  $P$  locally incident to  $A$  coincide, and not all the 3 regions of  $P$  locally project to one and the same half-plane of this tangent plane.



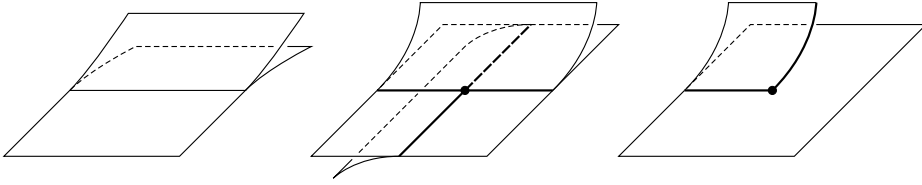

Figure 7. A polyhedron locally as in Figure 5 sitting in a branched fashion in a 3-manifold. Any mirror image in 3-space of these figures is also allowed.

- At a vertex  $A$  of  $P$  the tangent planes at  $A$  to the 6 regions of  $P$  locally incident to  $A$  coincide.
- At a spike  $A$  of  $P$  the tangent planes at  $A$  to the 2 regions of  $P$  locally incident to  $A$  coincide.

**PROPOSITION 1.2**

*To any stream spine  $P$  there correspond a smooth compact oriented 3-manifold  $M$  and a stream  $v$  on  $M$  such that  $P$  embeds in a branched fashion in  $M$ , the field  $v$  is everywhere positively transversal to  $P$ , and  $M$  is homeomorphic to a regular neighborhood of  $P$  in  $M$ ; the pair  $(M, v)$  is well defined up to oriented topological equivalence, therefore setting  $\varphi(P) = (M, v)$  one gets a well-defined map  $\varphi_0^* : \mathcal{S}_0 \rightarrow \mathcal{F}_0^*$ .*

*Proof*

Our first task is to show that  $P$  thickens in a PL sense to a well-defined oriented manifold  $M$ . (Later we will need to describe a smooth structure for  $M$  and the field  $v$ .) This argument extends that of [4]. Let us denote by  $U$  a regular neighborhood in  $P$  of the union of the triple lines. We observe that  $U$  can be seen as a union of fragments as in the top row of Figure 8, that we thicken as shown in the bottom row of the same figure, giving each block the orientation such that the screw orientations along the portions of triple lines of  $P$  within each block are positive. Note that on the boundary of each block there are some T-shaped regions and that some rectangles are highlighted. Following the way  $U$  is reassembled from the fragments into which it was decomposed, we can now assemble the blocks by gluing together the T's on their boundary. (Note that the gluing between two T's need not identify the vertical legs to each other, so each T should actually be thought of as a Y: the three legs play symmetric rôles.) Since the gluings automatically reverse the orientation, the result is an oriented manifold, on the boundary of which we have some highlighted strips, each having the shape of a rectangle or of an annulus. Now we turn to the closure in  $P$  of the complement of  $U$ , which we denote by  $S$ . Of course  $S$  is a surface with boundary, and on  $\partial S$  we can highlight the arcs and circles shared with  $U$ . (The rest of  $\partial S$  consists of arcs lying on single lines of  $P$ .) We then take the product  $S \times I$ —this is a crucial choice that will be discussed below—and note that the highlighted arcs and circles on  $\partial S$  give highlighted rectangles and annuli on  $\partial(S \times I)$ . We

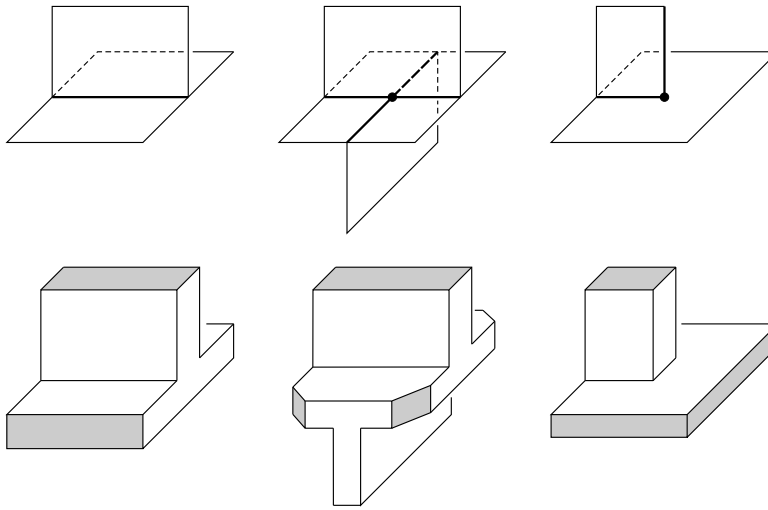

Figure 8. Blocks obtained by thickening fragments of a neighborhood of the union of the triple lines.

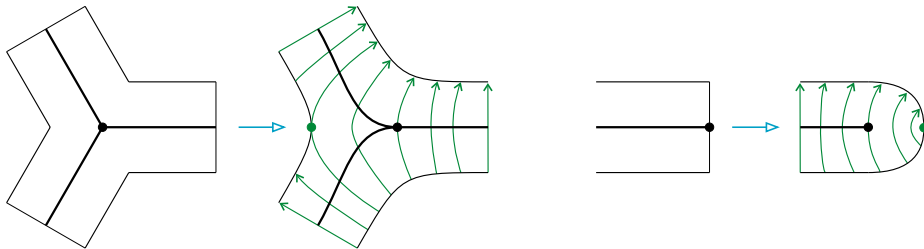

Figure 9. The stream along triple and single lines.

are only left to glue these rectangles and annuli to those on the boundary of the assembled blocks, respecting the way  $S$  is glued to  $U$  and making sure the orientation is reversed. The result is the required manifold  $M$ .

We must now explain how to smoothen  $M$  and how to choose the stream  $v$ . Away from the triple and single lines of  $P$  the manifold  $M$  is the product  $S \times I$  with  $S$  a surface, so it is sufficient to smoothen  $S$  and to define  $v$  to be parallel to the  $I$  factor and positively transversal to  $S$ . (This justifies our choice of thickening  $S$  as a trivial rather than some other  $I$ -bundle.) Along the triple and single lines of  $P$  we extend this construction as suggested in a cross section in Figure 9. Note that a triple line of  $P$  gives rise to a concave tangency line of  $v$  to  $\partial M$  and that a single line of  $P$  gives rise to a convex tangency line. To conclude we must illustrate the extension of the construction of  $v$  near vertices and near spikes, which we do in two examples in Figure 10. In the figure we represent  $v$  by showing some of its orbits. Note the following.

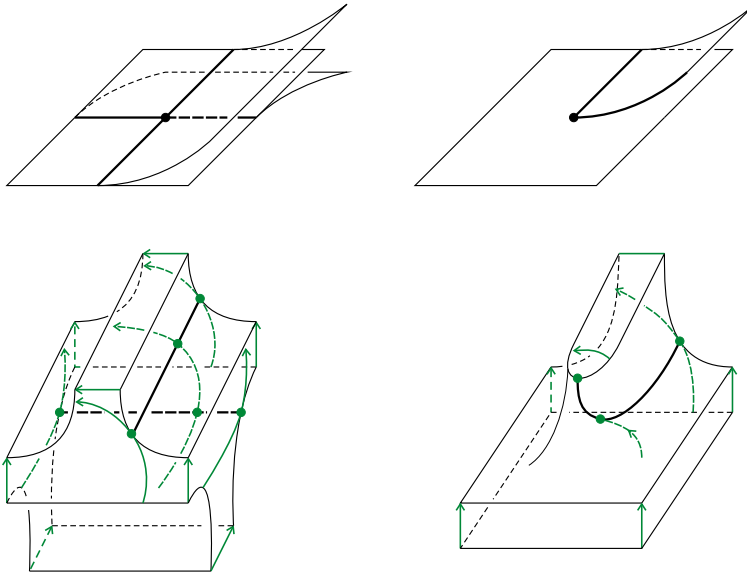

Figure 10. Stream carried by a stream spine near a vertex and near a spike.

- In both cases the local configurations of  $v$  near  $\partial M$  are as in condition (G1) of the definition of stream.
- The orbits of  $v$  are closed arcs or points, as in condition (G2).
- To a vertex of  $P$  there corresponds an orbit of  $v$  that is tangent to  $\partial M$  at two points, in a concave fashion and respecting the transversality condition (G4).
- To a spike of  $P$  there corresponds a transition orbit of  $v$  satisfying condition (G3).

This shows that  $v$  is indeed a stream on  $M$ . Since the construction of  $(M, v)$  is uniquely determined by  $P$ , the proof is complete.  $\square$

### 1.6. The in-backward and the out-forward stream spines of a stream

In this subsection we prove that the construction of Proposition 1.2 can be reversed, namely, that the map  $\varphi_0^* : \mathcal{S}_0 \rightarrow \mathcal{F}_0^*$  is bijective. More exactly, we will see that the topological construction has two inverses that are equivalent to each other—but not obviously so. If  $v$  is a stream on a 3-manifold  $M$  we define:

- the *in-backward* polyhedron associated to  $(M, v)$  as the closure of the union of the in-region of  $\partial M$  with the set of all points  $A$  such that there is an orbit of  $v$  going from  $A$  to a concave or transition point of  $\partial M$ ;
- the *out-forward* polyhedron associated to  $(M, v)$  as the closure of the union of the out-region of  $\partial M$  with the set of all points  $A$  such that there is an orbit of  $v$  going from a concave or transition point of  $\partial M$  to  $A$ .

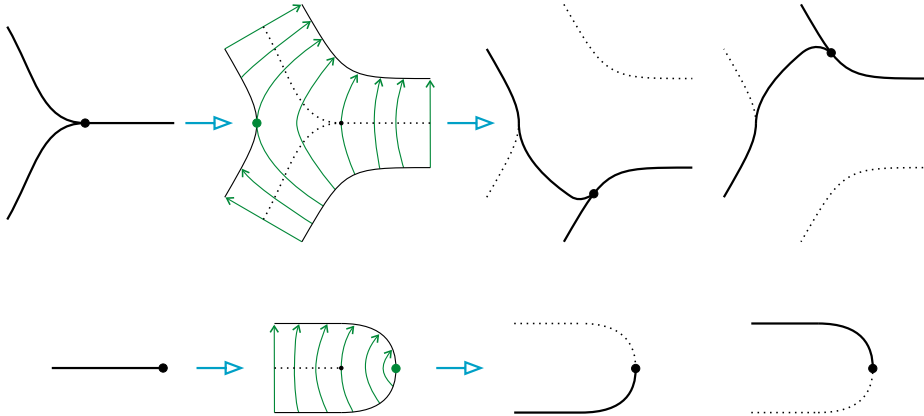

Figure 11. From a stream spine to a manifold-stream pair to its in-backward and out-forward polyhedra; cross-section away from the vertices and spikes of the stream-spine and away from the special orbits of the stream.

**PROPOSITION 1.3**

• Let  $v$  be a stream on  $M$ . Then the in-backward and out-forward polyhedra associated to  $(M, v)$  satisfy condition (S1) of the definition of stream spine; moreover, each of their regions shares some point with the in-region or with the out-region of  $\partial M$ , and it can be oriented so that at these points the field  $v$  is positive transversal to it; with this orientation on each region, the in-backward and out-forward polyhedra associated to  $(M, v)$  are stream spines, they are isomorphic to each other and via Proposition 1.2 they both define the pair  $(M, v)$ .

• If  $P$  is a stream spine and  $(M, v)$  is the associated manifold-stream pair as in Proposition 1.2, then the in-backward and out-forward polyhedra associated to  $(M, v)$  are isomorphic to  $P$ .

*Proof*

Most of the assertions are easy, so we confine ourselves to the main points. It is first of all obvious that away from the special orbits of  $v$  as in conditions (G3) and (G4) the concave tangency lines of  $v$  to  $\partial M$  generate triple lines in the in-backward and out-forward polyhedra associated to  $(M, v)$ , while convex tangency lines generate single lines. Moreover, if from a stream-spine  $P$  we go to  $(M, v)$  and then to the associated in-backward and out-forward polyhedra, away from the vertices and spikes of  $P$  we see that these polyhedra are naturally isomorphic to  $P$ , as shown in a cross section in Figure 11.

The fact that an orbit of  $v$  as in condition (G4) generates a vertex in the in-backward and out-forward polyhedra associated to  $(M, v)$  was already shown in [5], but we reproduce the argument here for the sake of completeness, showing on the left-hand side of Figure 12, top and bottom, the in-backward and the out-forward spines near the orbit of Figure 4. Both these spines are locally isomorphic to the stream-spine shown on the right-hand side, to which Proposition 1.2 associates precisely an orbit as in Figure 4.

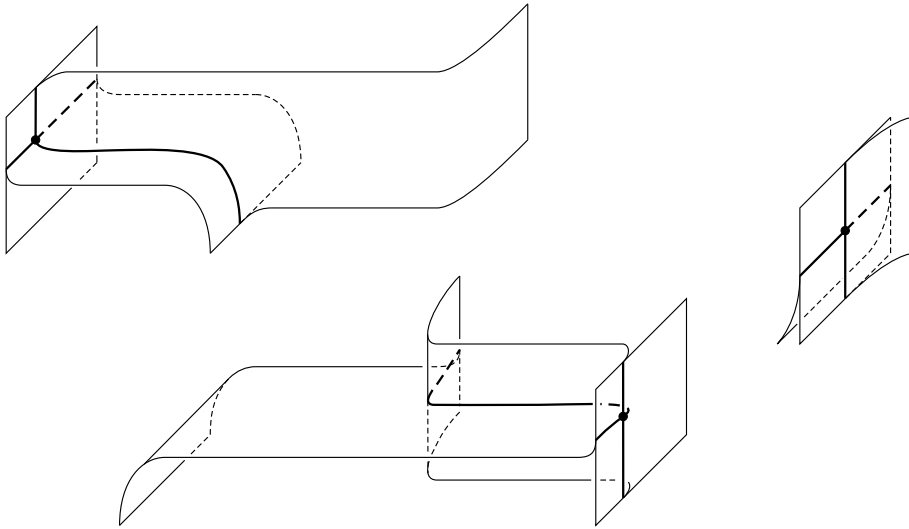

Figure 12. An orbit of a stream doubly tangent to the boundary in a concave fashion generates a vertex in the in-backward and in the out-forward stream-spines.

We are left to deal with transition points and with spikes. Let us concentrate on a concave-to-convex transition point as on the left-hand side of Figure 2 but mirrored and rotated in 3-space for convenience. In this case the transition orbit extends backward (and not forward), and the locally associated in-backward polyhedron is easy to describe, which we do at the top of Figure 13. The out-forward polyhedron is instead slightly more complicated to understand, since the orbits of  $v$  starting from the concave line near the transition point finish on points close to the transition one, as illustrated at the bottom of Figure 13. The picture shows that the spikes thus generated are indeed locally the same. Moreover, the concave-to-convex configuration of  $v$  near  $\partial M$  is precisely that generated by a spike as on the right-hand side of Figure 10, which is again of the same type. This concludes the proof.  $\square$

Combining Propositions 1.2 and 1.3 we get the following main result of this section.

**THEOREM 1.4**

*The map  $\varphi_0^* : \mathcal{S}_0 \rightarrow \mathcal{F}_0^*$  from the set of stream spines up to isomorphism to the set of streams on 3-manifolds up to topological equivalence.*

**2. Stream homotopy and sliding moves on stream spines**

In this section we consider a natural equivalence relation on streams, and we translate it into combinatorial moves on stream spines.

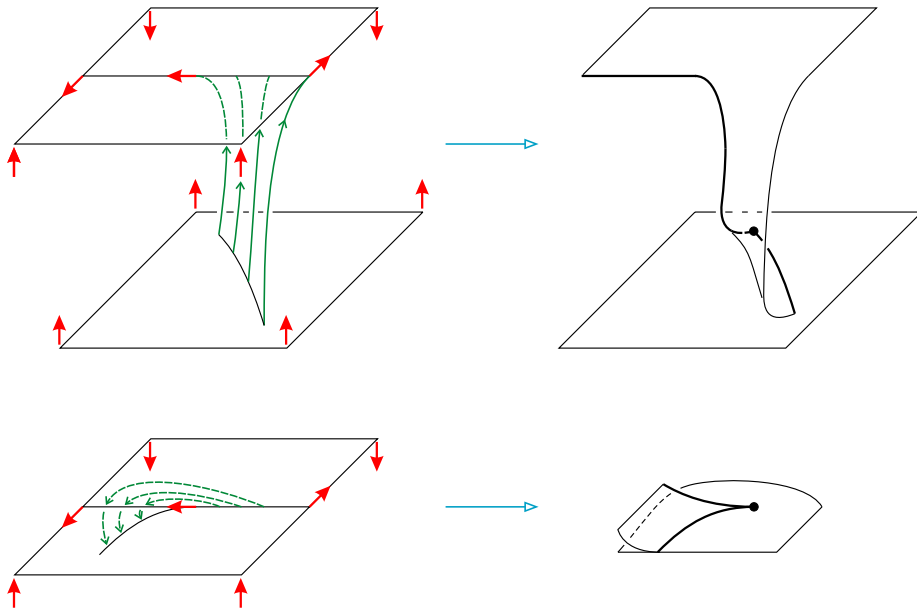

Figure 13. From a transition point to a spike in the in-backward and in the out-forward associated polyhedra.

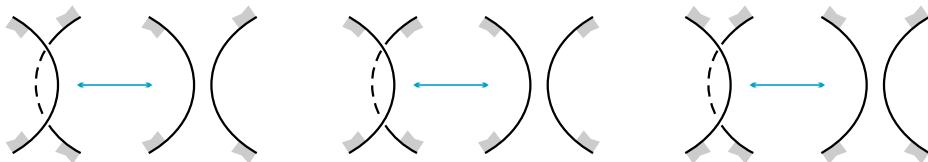

Figure 14. Catastrophes corresponding to an orbit being twice concavely tangent to the boundary but not in a transverse fashion. The pictures show portions of the concave tangency line as seen looking in the direction of the vector field, and they suggest to what part of it the boundary of the manifold bends.

### 2.1. Elementary homotopy catastrophes

Let  $M$  be an oriented 3-manifold with nonempty boundary. On the set  $\mathcal{F}_0^*$  of streams on  $M$  we define *stream homotopy* as the equivalence relation of homotopy through vector fields with fixed configuration on  $\partial M$  and all orbits homeomorphic to closed intervals or to points. We then define  $\mathcal{F}_0$  as the quotient of  $\mathcal{F}_0^*$  under the equivalence relation of stream homotopy. (Recall that the elements of  $\mathcal{F}_0^*$  itself are viewed up to topological equivalence.) The next result shows how to factor this relation into easier ones.

**PROPOSITION 2.1**

*Stream homotopy is generated by the elementary moves shown in Figures 14–16.*

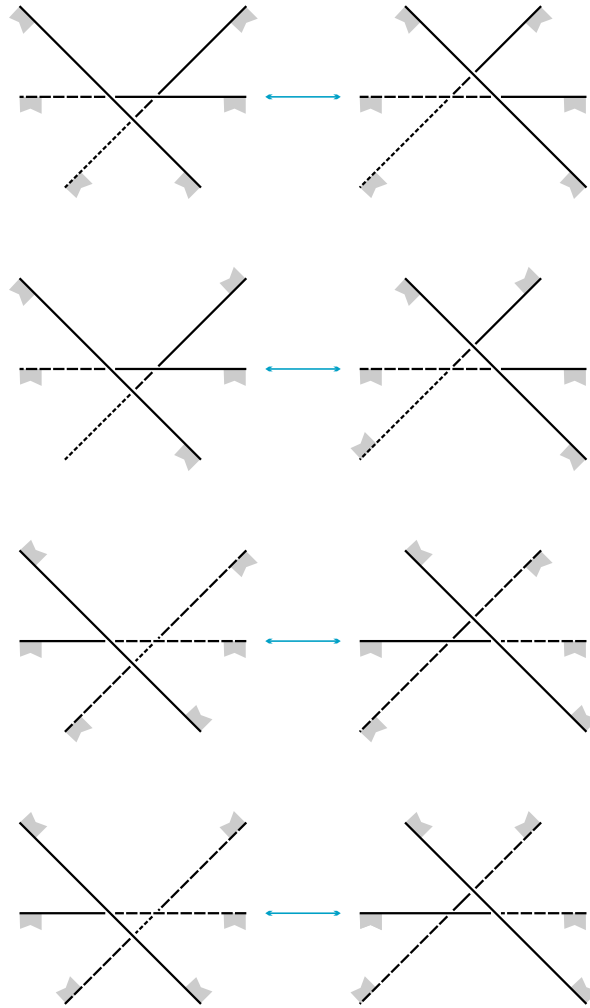

Figure 15. Catastrophes corresponding to an orbit being thrice concavely tangent to the boundary in a transverse fashion.

*Proof*

Let  $(v_t)_{t \in [0,1]}$  be a stream homotopy as just defined (so that conditions (G1) and (G2) hold or all  $v_t$ 's). Up to small perturbation we can assume the following.

- The genericity conditions (G3) and (G4) are violated at isolated times  $0 < t_1 < \dots < t_N < 1$  only.
- At each  $t_j$  there is a single orbit  $\gamma_j$  violating condition (G3) or (G4), and one of the following catastrophes happens:
  - (a)  $\gamma_j$  is twice concavely tangent to  $\partial M$  but not transversely;
  - (b)  $\gamma_j$  is thrice concavely tangent to  $\partial M$ , and transversely;
  - (c) One end of  $\gamma_j$  is a transition point, and one internal point of  $\gamma_j$  is concavely tangent to  $\partial M$ ;

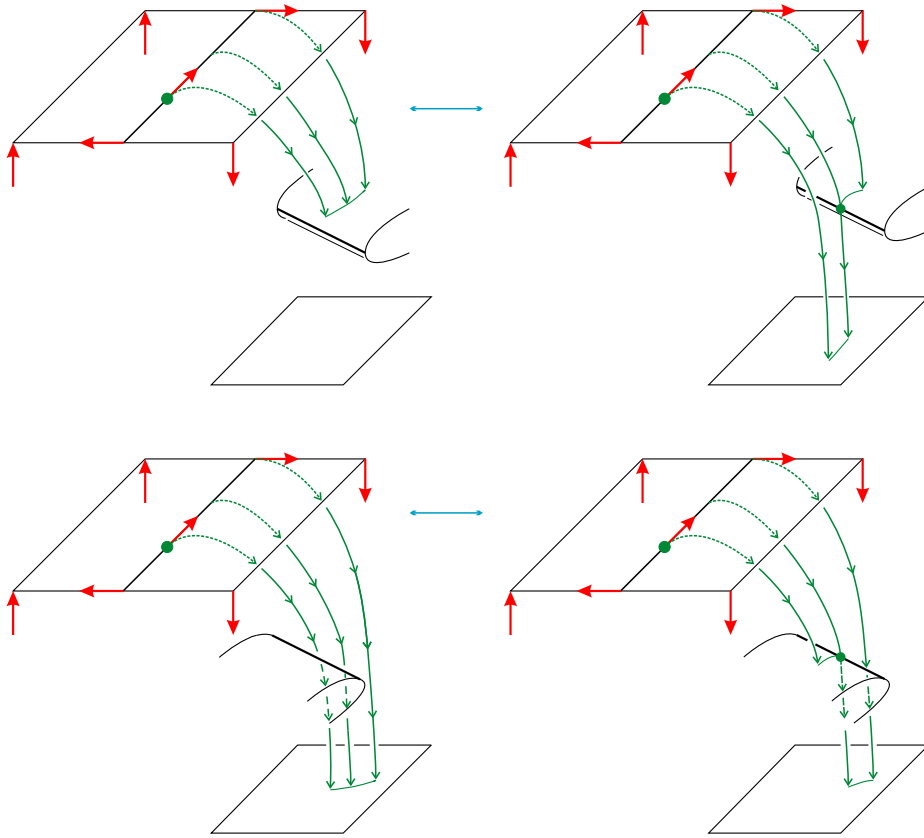

Figure 16. Catastrophes corresponding to a transition orbit being also once concavely tangent to the boundary, with an obvious transversality condition. These pictures refer to an incoming transition orbit, but the analogue catastrophes involving outgoing transition orbits must also be taken into account.

(d) Both ends of  $\gamma_j$  are transition points, and no internal point of  $\gamma_j$  is tangent to  $\partial M$ .

Since the topological equivalence class of  $v_t$  does not change for  $t \in (t_{j-1}, t_j)$ , we only need to analyze the effect of the catastrophes. Let us first assume that there is no catastrophe of type (d); then we can assume that for some small enough  $\varepsilon > 0$  the field  $v_t$  on  $[t_j - \varepsilon, t_j + \varepsilon]$  changes only near  $\gamma_j$  as described in Figure 14 for type (a), Figure 15 for type (b), and Figure 16 for type (c). Taking into account condition (G2) we then see that on each interval  $[0, t_1 - \varepsilon]$ ,  $[t_j + \varepsilon, t_{j+1} - \varepsilon]$ ,  $[t_N + \varepsilon, 1]$  the orbits of  $v_t$  evolve homeomorphically. This implies the statement when there is no type-(d) catastrophe. To conclude we must then show that this type of catastrophe can be generically avoided during a homotopy. To do so we carefully analyze in Figure 17 the initial portions of the orbits close to an incoming transition orbit. In a catastrophe of type (d) we would have a concave-to-convex transition point  $A$  such that the orbit through  $A$  traces backward to, say, orbit 1 just before the catastrophe, to orbit 0 at the catastrophe, and to



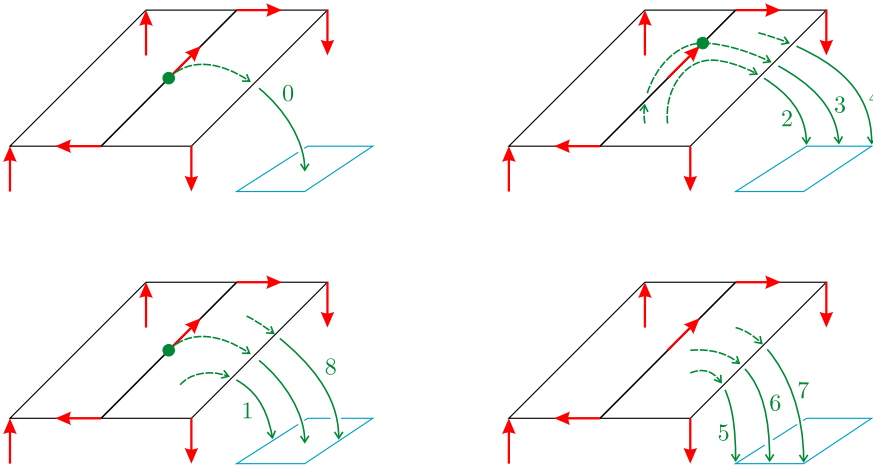

Figure 17. Initial portions of orbits near an incoming transition orbit.

orbit 8 just after the catastrophe, with numbers as in Figure 17. We can now modify the homotopy so that the orbit through  $A$  traces back to either

- orbit 1, then 2, then 3, then 4, then 8, or
- orbit 1, then 5, then 6, then 7, then 8.

Note that at  $A$  with the first choice we obviously create a catastrophe of type (c) but for an outgoing transition orbit, while with the second choice we do not create any catastrophe at  $A$ . On the other hand at the starting point of orbit 0 in Figure 17 we could create a catastrophe of type (c) with one of the two choices and no catastrophe with the other choice, but we cannot predict which is which. This shows that we can always get rid of a doubly transition orbit either at no cost or by inserting one catastrophe of type (c).  $\square$

### 2.2. Sliding moves on stream spines

In this subsection we introduce certain combinatorial moves on stream spines. We do so showing pictures and always meaning that the mirror images in 3-space of the moves that we represent are also allowed and named in the same way. The list is as follows:

- a *sliding*  $0 \leftrightarrow 2$  move is any move as in Figure 18;
- a *sliding*  $2 \leftrightarrow 3$  move is any move as in Figure 19;
- a *spike-sliding* move is any move as in Figure 20;
- a *sliding* move is any move of the types just described.

The following result is evident.

#### PROPOSITION 2.2

If two stream spines  $P_1$  and  $P_2$  in  $\mathcal{S}_0$  are related by a sliding move, then the corresponding streams  $\varphi_0^*(P_1)$  and  $\varphi_0^*(P_2)$  are stream-homotopic to each other.

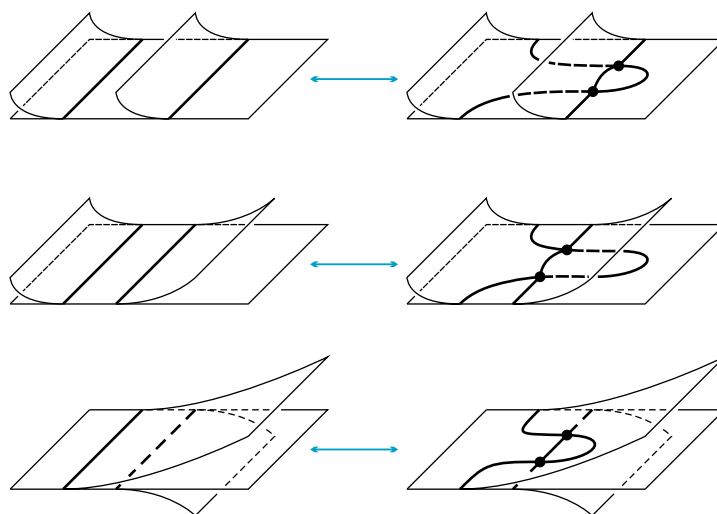

Figure 18. The  $0 \leftrightarrow 2$  sliding moves.

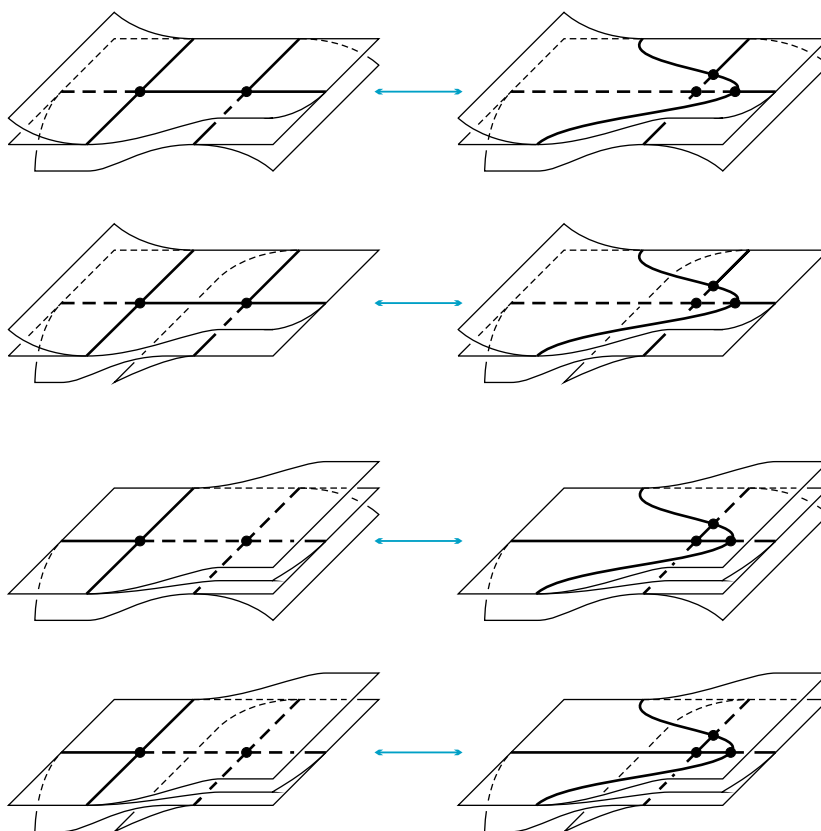

Figure 19. The  $2 \leftrightarrow 3$  sliding moves.

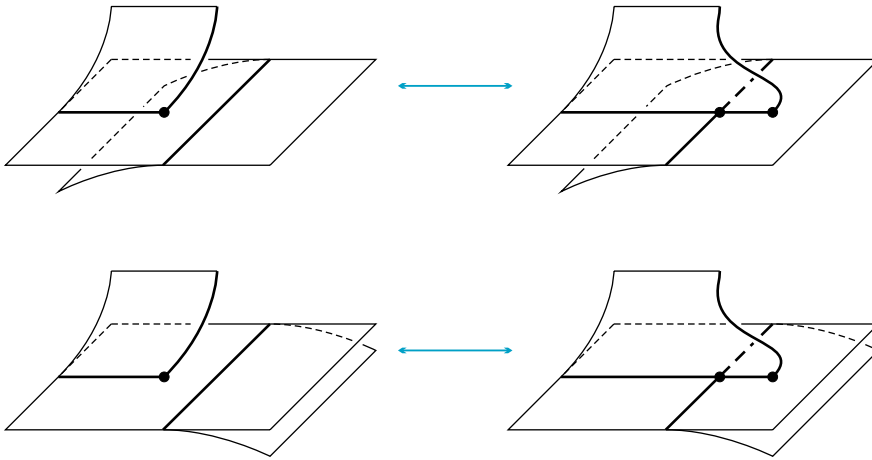

Figure 20. The spike-sliding moves.

### 2.3. Translating catastrophes into moves

In this subsection we establish the following.

#### THEOREM 2.3

Let  $\varphi_0 : \mathcal{S}_0 \rightarrow \mathcal{F}_0$  be the surjection from the set of stream spines to the set of streams on 3-manifolds up to homotopy. Then  $\varphi_0(P_1)$  and  $\varphi_0(P_2)$  coincide in  $\mathcal{F}_0$  if and only if  $P_1$  and  $P_2$  are related by sliding moves.

#### *Proof*

We must show that the elementary catastrophes along a generic stream homotopy, as described in Proposition 2.1, correspond at the level of stream spines to the sliding moves. Checking that the catastrophes of Figures 14 and 15 correspond to the  $0 \leftrightarrow 2$  and  $2 \leftrightarrow 3$  sliding moves is easy and already described in [5], so we do not reproduce the argument.

We then concentrate on the catastrophes of Figure 16, showing that on the associated out-forward spines their effect is that of a spike-sliding. This is done in Figure 21 for the catastrophe in the top portion of Figure 16, which is then easily recognized to give the first spike-sliding move of Figure 20; a very similar picture shows that the bottom portion of Figure 16 gives the second spike-sliding move of Figure 20.

The proof is now complete, and the isomorphism of the in-backward and out-forward stream spines implies that the effect of the catastrophes of Figure 16 is that of a spike-sliding also on the in-backward stream spine. It is, however, instructive to analyze the effect directly on the in-backward stream spine—in fact, it is not even obvious at first sight that the catastrophes of Figure 16 have any impact on the in-backward stream spine, given that there is no transition orbit to follow backward anyway. But the catastrophes of Figure 16 do have an impact on the in-backward stream-spine, because at the catastrophe time there is an orbit

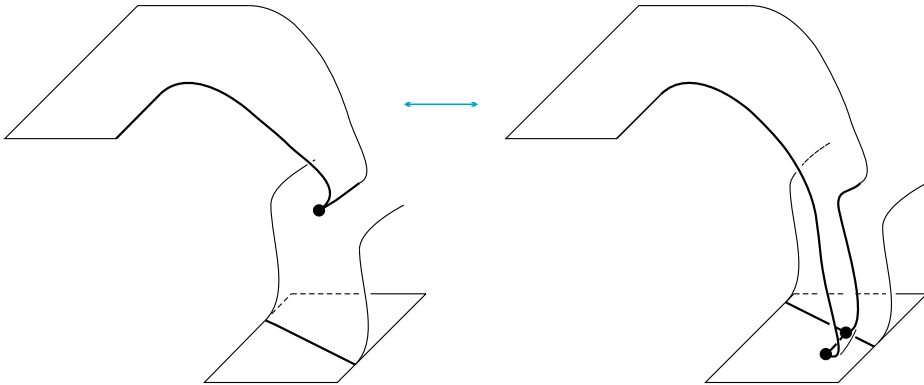

Figure 21. From a catastrophe involving concave tangency of an incoming transition orbit to a spike-sliding in the associated out-forward stream spine.

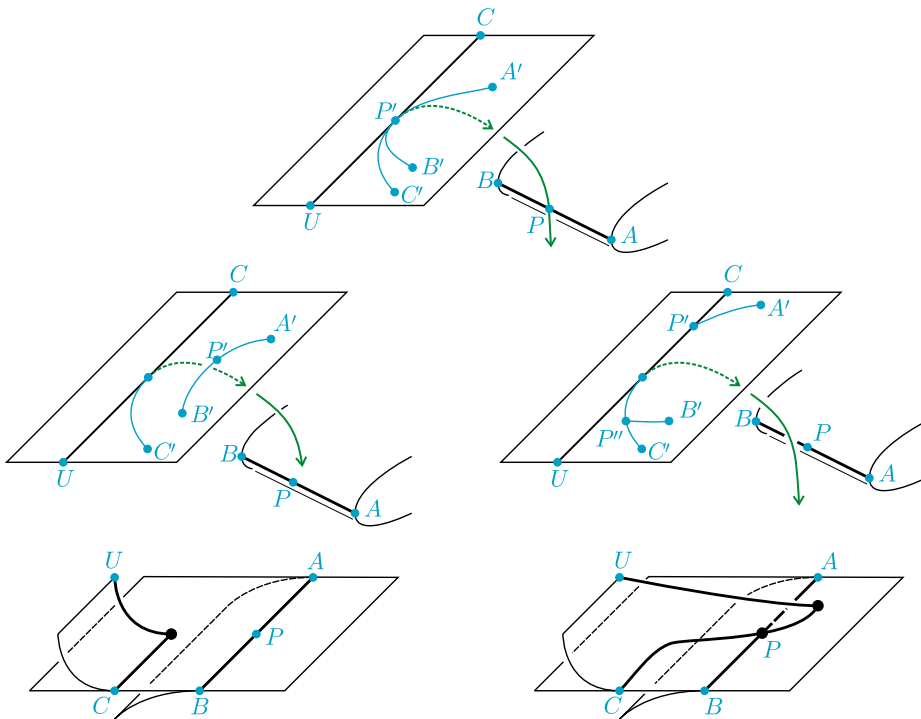

Figure 22. From a catastrophe involving concave tangency of an incoming transition orbit to a spike-sliding in the associated in-backward stream spine.

that from a concave tangency point traces back to a transition point. To analyze what the impact exactly is, we restrict to the top portion of Figure 16 and we employ Figure 17 in a crucial fashion. We do this in Figure 22, where we show the exact time of the catastrophe (top), the situation before (middle-left) and after

(middle-right) the catastrophe, and the corresponding in-backward stream spines (bottom). In the middle figures we show how the concave tangency lines trace back to the in-region, showing for some points  $Q$  the boundary point  $Q'$  obtained by following the orbit backward through  $Q$ ; note that after the catastrophe one point  $P$  traces back first to a point  $P'$  of the concave tangency line and then to a point  $P''$  of the in-region. Using the information of the middle figures one indeed sees that the corresponding stream spines are as in the bottom figures, where one recognizes the first spike-sliding of Figure 20.  $\square$

### 3. Combinatorial presentation of generic flows

As already anticipated, let us now define  $\mathcal{F}$  as the set of pairs  $(M, v)$  where  $M$  is a compact, connected, oriented 3-manifold (possibly without boundary) and  $v$  is a generic flow on  $M$ , viewed up to the equivalence relation generated by the following:

- $(M_0, v_0)$  is equivalent to  $(M_1, v_1)$  if there exists a homeomorphism of  $M_0$  onto  $M_1$  mapping the oriented orbits of  $v_0$  to those of  $v_1$ ;
- $(M, v_0)$  is equivalent to  $(M, v_1)$  if there exists a continuous homotopy  $(v_t)_{t \in [0,1]}$  with fixed (in/out/convex/concave/transition) configuration on  $\partial M$ .

(So  $\mathcal{F}$  is a quotient of  $\mathcal{F}_0$ .) To provide a combinatorial presentation of  $\mathcal{F}$  we define

- a *trivial sphere* on the boundary of some  $(N, w)$  as one that is split into one in-disc and one out-disc by one concave tangency circle;
- a *trivial ball* as a ball  $(B^3, u)$  with  $u$  a stream on  $B^3$  and  $\partial B^3$  split into one in-disc and one out-disc by one convex tangency circle.

Note that a trivial ball can be glued to a trivial sphere matching the vector fields. We now define  $\mathcal{S}$  as the subset of  $\mathcal{S}_0$  consisting of stream spines  $P$  such that the boundary of  $\varphi_0(P)$  contains at least one trivial sphere. We will establish the following.

#### THEOREM 3.1

*For  $P \in \mathcal{S}$  let  $\varphi(P)$  be obtained from  $\varphi_0(P)$  by attaching a trivial ball to a trivial sphere in the boundary of  $\varphi_0(P)$ . This gives a well-defined surjective map  $\varphi : \mathcal{S} \rightarrow \mathcal{F}$ , and  $\varphi(P_0) = \varphi(P_1)$  if and only if  $P_0$  and  $P_1$  are obtained from each other by the sliding moves of Figures 18–20.*

#### 3.1. Equivalence of trivial balls

In this subsection we will show that the map  $\varphi$  of Theorem 3.1 is well defined. To this end choose  $P \in \mathcal{S}$ , and set  $(N, w) = \varphi_0(P)$ . To define  $\varphi(P)$  we must choose one trivial sphere  $S \subset \partial N$ , a trivial ball  $(B^3, u)$ , and a diffeomorphism  $f : \partial B^3 \rightarrow S$  matching  $u$  to  $w$ . The manifold  $M$  resulting from the gluing is of course independent of  $S$ , and the resulting flow  $v$  on  $M$  is of course independent of  $f$  up to homotopy. However, when the boundary of  $\varphi_0(P)$  contains more than

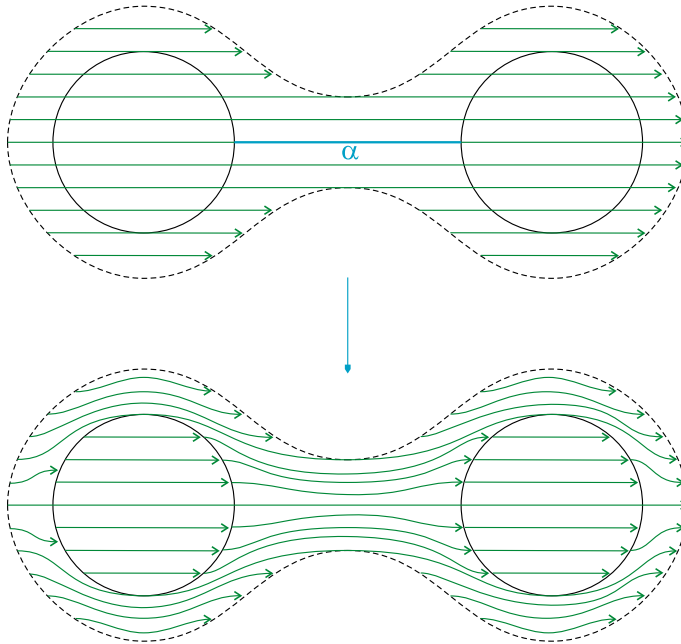

Figure 23. Homotoping a field so that removing either of two trivial balls gives the same result.

one trivial sphere, it is not obvious that the pair  $(M, v)$  as an element of  $\mathcal{F}$  is independent of  $S$ . This will be a consequence of the following.

**PROPOSITION 3.2**

Let  $v$  be a generic flow on  $M$ , and let  $B_1$  and  $B_2$  be disjoint trivial balls contained in the interior of  $M$ . Then there is a flow  $v'$  on  $M$  homotopic to  $v$  relatively to  $(\partial M) \cup B_1 \cup B_2$  such that there is a homeomorphism from  $\overline{M \setminus B_1}$  to  $\overline{M \setminus B_2}$  mapping the oriented orbits of  $v'$  restricted to  $\overline{M \setminus B_1}$  to the oriented orbits of  $v'$  restricted to  $\overline{M \setminus B_2}$ .

*Proof*

Choose a smooth path  $\alpha : [0, 1] \rightarrow M$  with  $\alpha(j) \in \partial B_j$  and  $\dot{\alpha}(j) = v(\alpha(j))$  not tangent to  $\partial B_j$  for  $j = 0, 1$ , and  $\alpha(t) \notin B_1 \cup B_2$  for  $0 < t < 1$ . Up to small perturbation we can assume that  $\dot{\alpha}(t) \neq -v(\alpha(t))$  for  $t \in [0, 1]$ , and then homotope  $v$  on a neighborhood of  $\alpha$  to a flow  $v''$  such that  $v''(\alpha(t)) = \dot{\alpha}(t)$  for  $t \in [0, 1]$ . Now we can homotope  $v''$  to  $v'$  in a neighborhood of  $B_1 \cup B_2 \cup \alpha$  as suggested in Figure 23, which gives the desired conclusion.  $\square$

**3.2. Normal sections**

Let us now show that the map  $\varphi$  of Theorem 3.1 is surjective. To this end we adapt a definition from [5] and [7], defining a *normal section* for a manifold  $M$  with generic flow  $v$  as a smooth disc  $\Delta$  in the interior of  $M$  such that  $v$  is transverse to  $\Delta$ , every orbit of  $v$  meets  $\Delta \cup \partial M$  in both positive and negative time, and

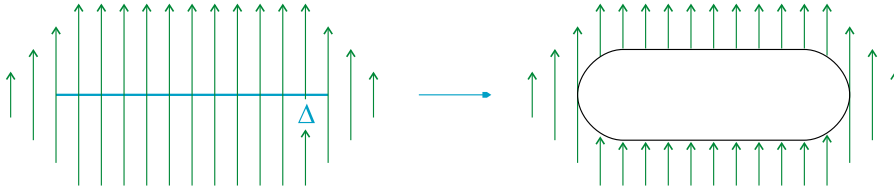

Figure 24. From a normal section to a stream on the complement of a trivial ball.

the orbits of  $v$  tangent to  $\partial M$  or intersecting  $\partial\Delta$  are generic with respect to each other, with the obvious meaning. The existence of normal sections is rather easily established in [5], and Figure 24 suggests how, given a normal section  $\Delta$  of  $(M, v)$ , to remove a trivial ball  $B$  from  $(M, v)$  so that the restriction  $w$  of  $v$  to  $N = M \setminus B$  is a stream on  $N$ . By construction if  $P$  is a stream spine such that  $\varphi_0^*(P) = (N, w)$ , we have that  $\varphi(P)$  represents  $(M, v)$ , whence the surjectivity of  $\varphi$ . Let us also note, since we will need this to prove injectivity, that  $P$  can be directly recovered from  $(M, v)$  and  $\Delta$ , taking the union of  $\Delta$  with the in-region of  $\partial M$  and with the set of points  $A$  such that there exists an orbit of  $v$  going from  $A$  to  $\partial\Delta$  or to the concave tangency line of  $v$  to  $\partial M$ , with the obvious branching along triple lines.

### 3.3. Homotopy

We are left to establish injectivity of the map  $\varphi$  of Theorem 3.1. Recalling that the elements  $(M, v)$  of  $\mathcal{F}$  are regarded up to an orbit-preserving homeomorphism of  $M$  and a homotopy of  $v$  on  $M$  with fixed configuration on  $\partial M$ , we see that injectivity is a consequence of the following.

**PROPOSITION 3.3**

*Let  $(v_t)_{t \in [0,1]}$  be a homotopy of generic flows on  $M$ , with fixed configuration on  $\partial M$ . For  $j = 0, 1$  let  $\Delta_j$  be a normal section for  $(M, v_j)$ , and let  $P_j$  be the stream-spine defined by  $\Delta_j$  and  $v_j$  as at the end of Section 3.2. Then  $P_0$  and  $P_1$  are related by the sliding moves of Figures 18–20.*

*Proof*

We first prove the result for constant  $(v_t)$ . Namely, we prove that if  $\Sigma_0$  and  $\Sigma_1$  are normal sections for the same  $(M, v)$ , then the associated stream spines are related by the sliding moves of Figures 18–20. This is proved, as in [5], by constructing normal sections  $\Theta_0$  and  $\Theta_1$  for  $(M, v)$  such that  $\Sigma_0 \cap \Theta_0 = \Theta_0 \cap \Theta_1 = \Theta_1 \cap \Sigma_1 = \emptyset$ , which is easily done. The conclusion now comes from the fact that given two disjoint normal sections  $X$  and  $Y$  of  $(M, v)$  one can join them by a small strip constructing a normal section  $Z$  that contains  $X \cup Y$ , and then one can view the transformation of  $X$  into  $Y$  as first the smooth expansion of  $X$  to  $Z$  and then the contraction of  $Z$  to  $Y$ . At the level of the associated stream spines this transition indeed consists of the elementary sliding moves of Figures 18–20.

Let us now treat the general case of the statement. For all  $t \in [0, 1]$  we choose a normal section  $\Delta_t$  for  $v_t$  (with  $\Delta_0$  and  $\Delta_1$  the sections we have by assumption). For all  $t$  there exists  $\varepsilon(t) > 0$  such that  $\Delta_t$  is a normal section of  $v_s$  for all  $s \in (t - \varepsilon(t), t + \varepsilon(t)) \cap [0, 1]$ , with associated stream spine independent of  $s$  up to isomorphism. By compactness of  $[0, 1]$  we can find times  $0 = t_0 < t_1 < \dots < t_N = 1$  and discs  $\Delta_0 = D_0, D_1, \dots, D_{N-1} = \Delta_1$  such that  $D_j$  is a normal section of  $v_s$  for all  $s \in [t_j, t_{j+1}]$ , with associated stream spine independent of  $s$  up to isomorphism. What is already shown implies that the stream spines of  $v_j$  defined by  $D_{j-1}$  and by  $D_j$  are related by the elementary sliding moves of Figures 18–20, and the conclusion readily follows.  $\square$

#### REMARK 3.4

Suppose for  $j = 1, 2$  that  $M_j$  is an oriented 3-manifold endowed with a generic flow  $v_j$  and that  $\Sigma_j$  is a boundary component of  $M_j$ . Suppose moreover that one is given a homeomorphism  $\Sigma_1 \rightarrow \Sigma_2$  mapping the in-region of  $\Sigma_1$  to the out-region of  $\Sigma_2$  and conversely, the concave line on  $\Sigma_1$  to the convex line on  $\Sigma_2$  and conversely, the concave-to-convex transition points of  $\Sigma_1$  to the convex-to-concave transition points of  $\Sigma_2$  and conversely. Then one can glue  $M_1$  to  $M_2$  along this map, getting on the resulting manifold  $M$  a generic flow  $v$  well defined up to homotopy. This implies that there exists a natural cobordism theory in the set  $\mathcal{F}$  of 3-manifolds endowed with a generic flow, and one could hope to use the combinatorial encoding  $\varphi : \mathcal{S} \rightarrow \mathcal{F}$  described in this paper as a technical tool to develop a TQFT (see [12]) for such manifolds.

*Acknowledgments.* The author profited from several inspiring discussions with Riccardo Benedetti. He also thanks the anonymous referees for precious suggestions.

## References

- [1] S. Baseilhac and R. Benedetti, *Quantum hyperbolic invariants of 3-manifolds with  $\mathrm{PSL}(2, \mathbb{C})$ -characters*, *Topology* **43** (2004), 1373–1423. [MR 2081430](#). [DOI 10.1016/j.top.2004.02.001](#).
- [2] ———, *Classical and quantum dilogarithmic invariants of flat  $\mathrm{PSL}(2, \mathbb{C})$ -bundles over 3-manifolds*, *Geom. Topol.* **9** (2005), 493–569. [MR 2140989](#). [DOI 10.2140/gt.2005.9.493](#).
- [3] ———, *Quantum hyperbolic geometry*, *Algebr. Geom. Topol.* **7** (2007), 845–917. [MR 2336244](#). [DOI 10.2140/agt.2007.7.845](#).
- [4] R. Benedetti and C. Petronio, *A finite graphic calculus for 3-manifolds*, *Manuscripta Math.* **88** (1995), 291–310. [MR 1359699](#). [DOI 10.1007/BF02567824](#).
- [5] ———, *Branched Standard Spines of 3-Manifolds*, *Lecture Notes in Math.* **1653**, Springer, Berlin, 1997. [MR 1470454](#).



- [6] J. Christy, *Branched surfaces and attractors, I: Dynamic branched surfaces*, Trans. Amer. Math. Soc. **336** (1993), 759–784. MR 1148043.  
DOI 10.2307/2154374.
- [7] I. Ishii, *Flows and spines*, Tokyo J. Math. **9** (1986), 505–525. MR 0875203.  
DOI 10.3836/tjm/1270150734.
- [8] S. V. Matveev, *Complexity theory of three-dimensional manifolds*, Acta Appl. Math. **19** (1990), 101–130. MR 1074221.
- [9] B. Morin, *Formes canoniques des singularités d'une application différentiable*, C. R. Acad. Sci. Paris **260** (1965), 6503–6506. MR 0190944.
- [10] N. Reshetikhin and V. G. Turaev, *Invariants of 3-manifolds via link polynomials and quantum groups*, Invent. Math. **103** (1991), 547–597.  
MR 1091619. DOI 10.1007/BF01239527.
- [11] C. Robinson, *Dynamical Systems: Stability, Symbolic Dynamics, and Chaos*, 2nd ed., Stud. Adv. Math., CRC Press, Boca Raton, Fla., 1999. MR 1792240.
- [12] V. G. Turaev, *Quantum invariants of knots and 3-manifolds*, de Gruyter Stud. Math. **18**, de Gruyter, Berlin, 1994. MR 1292673.
- [13] V. G. Turaev and O. Y. Viro, *State sum invariants of 3-manifolds and quantum 6j-symbols*, Topology **31** (1992), 865–902. MR 1191386.  
DOI 10.1016/0040-9383(92)90015-A.
- [14] R. F. Williams, *Expanding attractors*, Inst. Hautes Études Sci. Publ. Math. **43** (1974), 169–203. MR 0348794.

Dipartimento di Matematica, Università di Pisa, Largo Bruno Pontecorvo, 5, 56127  
Pisa, Italy; [petronio@dm.unipi.it](mailto:petronio@dm.unipi.it)