

Genus one Birkhoff sections for the geodesic flows of hyperbolic 2-orbifolds

Norikazu Hashiguchi and Hiroyuki Minakawa

Abstract.

A hyperbolic 2-sphere is made from the double of an n -gon in Poincaré disc. Its geodesic flow is a transitive Anosov flow. We construct genus one Birkhoff sections for the geodesic flows of hyperbolic 2-spheres with n (≥ 3) singularities.

§1. Introduction

Since Anosov published the study of the geodesic flows on negatively curved Riemannian manifolds [1], Anosov flows have been continuously studied. If a flow has a dense orbit, we call it *transitive*. Verjovsky showed that any codimension one Anosov flow on a closed manifold whose dimension is greater than 3 is transitive [14]. But in 3-dimensional case, Franks and Williams constructed a non-transitive Anosov flow [6]. On the other hand, there are many examples of topologically transitive Anosov flows on 3-manifolds. We construct these examples by doing Dehn surgeries along closed orbits of suspension Anosov flows which is defined by Goodman [8] and is extended by Fried [5]. These transitive flows admit genus one Birkhoff sections.

Definition ([2, 5]). *A Birkhoff section for a flow φ_t on a closed connected 3-manifold is an immersed compact connected surface S satisfying the following conditions.*

- (1) *The interior of S is embedded and transverse to φ_t .*
- (2) *Each boundary component of S covers a closed orbit of φ_t .*
- (3) *Every orbit of φ_t meets S within a uniformly bounded time.*

Received June 30, 2014.

Revised December 1, 2014.

2010 *Mathematics Subject Classification*. Primary 37D40; Secondary 57R18, 57R30.

Key words and phrases. Birkhoff section, hyperbolic orbifold, geodesic flow, transitive Anosov flow.

Fried also proved that any topologically transitive Anosov flow on a 3-manifold has a Birkhoff section and it is constructed by doing Dehn surgeries along finitely many closed orbits of a suspension of a (pseudo-) Anosov homeomorphism of a closed surface. For example, the geodesic flow on a closed surface Σ with constant negative curvature admits a punctured torus as a Birkhoff section and this flow is made of the suspension of a hyperbolic toral automorphism. This toral automorphism is induced by

$$A_g = \begin{pmatrix} 2g^2 - 1 & 2g(g-1) \\ 2g(g+1) & 2g^2 - 1 \end{pmatrix} \in SL(2; \mathbf{Z})$$

where $g \geq 2$ is the genus of Σ [9]. Brunella showed that this geodesic flow is also constructed from

$$B_g = \begin{pmatrix} 4g^2 - 2g - 1 & 2g^2 - 2g \\ 8g^2 - 2 & 4g^2 - 2g - 1 \end{pmatrix} \in SL(2; \mathbf{Z})$$

[3]. Brunella prepared other genus one Birkhoff sections in order to calculate B_g .

The following is a natural question.

Question (Fried, [4]). Does every transitive 3-dimensional Anosov flow admit a genus one Birkhoff section?

Dehornoy constructs genus one Birkhoff sections for geodesic flows of hyperbolic 2-orbifolds which are 2-spheres with three or four singularities.

In this article, we consider wider class of hyperbolic 2-orbifolds. We construct genus one Birkhoff sections for the geodesic flows of hyperbolic 2-orbifolds which are 2-spheres with n -singularities ($n \geq 3$). We provide a few new methods of constructing Birkhoff sections of geodesic flows. In the case of $n = 3, 4$, our methods are independent and different from those of Dehornoy. In the case of $n \geq 5$, we have found a hybrid of our construction by using convex curves and that by using oriented geodesic segments. (See [4]. See also [3].)

Theorem. *Suppose we are given a positive integer $n \geq 5$. And suppose we are given n integers p_1, p_2, \dots, p_n with $n - 2 - \sum_{i=1}^n \frac{1}{p_i} > 0$, which satisfy either*

- (1) $p_i \geq 4$ for any i , or
- (2) n is even.

Then, there is a hyperbolic 2-orbifold of signature $(0; p_1, p_2, \dots, p_n)$ whose geodesic flow has a genus one Birkhoff section.

We also calculate hyperbolic toral automorphisms corresponding to the first return maps associated with some above Birkhoff sections.

§2. The geodesic flows of the 2-spheres with three singularities

2.1. The geodesic flows of hyperbolic 2-orbifolds

For any three positive integers p, q, r satisfying that $\frac{1}{p} + \frac{1}{q} + \frac{1}{r} < 1$, let $S(p, q, r)$ be a 2-sphere with three singularities X, Y, Z whose cone angles are $\frac{2\pi}{p}, \frac{2\pi}{q}, \frac{2\pi}{r}$ respectively (see Figure 1).

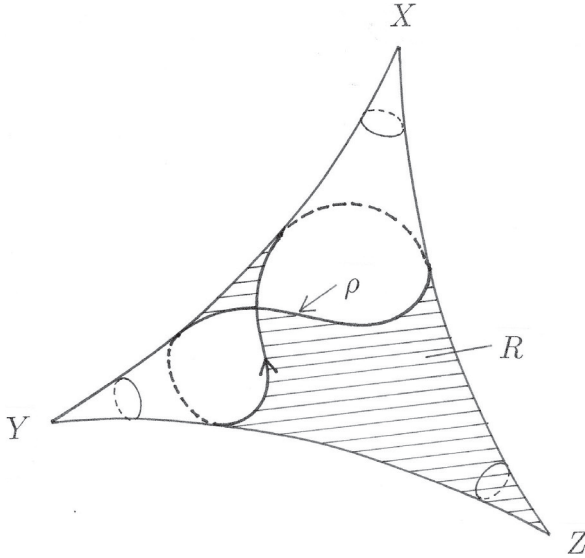

Fig. 1. $S(p, q, r)$.

We can consider $S(p, q, r)$ as a quotient space of Poincaré disc D^2 by an action of a triangle group in the following fashion. By the abuse of the notation, let $XYZ \subset D^2$ be a triangle with angles $\frac{\pi}{p}, \frac{\pi}{q}$ and $\frac{\pi}{r}$ (see Figure 2).

Let $\Gamma_*(p, q, r)$ denote the group of isometries of D^2 generated by reflections in the side ZX, XY and YZ , and $\Gamma(p, q, r)$, the orientation preserving subgroup of $\Gamma_*(p, q, r)$. $\Gamma(p, q, r)$ is the triangle group

$$\langle \tau_1, \tau_2, \tau_3; (\tau_1)^p = (\tau_2)^q = (\tau_3)^r = \tau_1 \tau_2 \tau_3 = 1 \rangle$$

where τ_1, τ_2 and τ_3 are clockwise rotations about X, Y and Z through angles of $\frac{2\pi}{p}, \frac{2\pi}{q}$ and $\frac{2\pi}{r}$ respectively. The fundamental region of $\Gamma(p, q, r)$

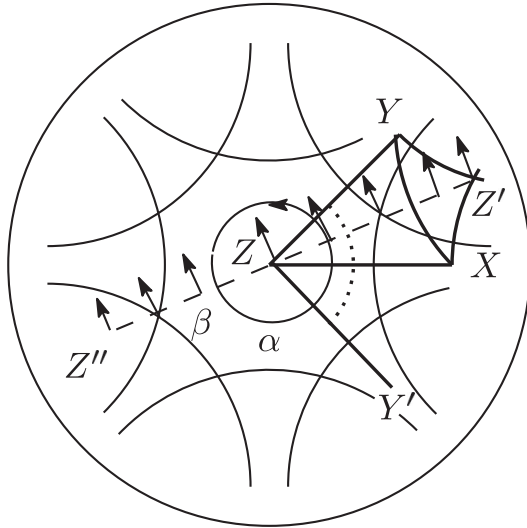

Fig. 2. Poincaré disc D^2 .

is two of original triangle XYZ [11]. So the quotient space $D^2/\Gamma(p, q, r)$ is the orbifold $S(p, q, r)$ whose fundamental group as orbifold is $\Gamma(p, q, r)$. $\Gamma(p, q, r)$ also acts the unit tangent bundle T_1D^2 of D^2 . The action of $\Gamma(p, q, r)$ preserves geodesics in D^2 . Hence the geodesic flow on D^2 induces the flow F_t on $T_1D^2/\Gamma(p, q, r) = M(p, q, r)$ which is a Seifert fibred space over $S(p, q, r)$. We call this flow F_t on $M(p, q, r)$ the geodesic flow on $S(p, q, r)$.

Remark 2.1. F_t is a transitive Anosov flow.

2.2. Birkhoff section for F_t

In this subsection, we will construct a Birkhoff section S for F_t which is homeomorphic to the 2-dimensional torus with two discs deleted. Then, the first return map associated with S gives us the matrices $A_{p,q,r} \in SL(2; \mathbf{Z})$.

To make a good Birkhoff section for the geodesic flow, we use the same method as [5, 7] (see also [9, 3]). Before making it, we review closed orbits of F_t .

Lemma 2.2 ([13]). *In $\Gamma(p, q, r)$, $\tau_1\tau_2^{-1}$ has finite order if and only if one of the following holds*

- (a) $(p - 2)(q - 2) = 0$,
- (b) $(p - 3)(q - 3) = 0$ and $r = 2$.

Therefore, if $\tau_1\tau_2^{-1}$ is represented by an immersed geodesic loop in $S(p, q, r)$, then one of the following holds;

- (a) $(p - 2)(q - 2)(r - 2) \neq 0$.
- (b) $(p - 2)(p - 3)(q - 2)(q - 3) \neq 0$.

In these cases, $\tau_1\tau_2^{-1}$ is of infinite order. Since $S(p, q, r)$ is compact without end, $\tau_1\tau_2^{-1}$ is a hyperbolic isometry of D^2 . But the axis l of $\tau_1\tau_2^{-1}$ does not always draw a figure eight loop in $S(p, q, r)$. We need a closed geodesic as a figure eight loop in order to get a Birkhoff section which is homeomorphic to the torus with two discs deleted [3].

Lemma 2.3 ([13]). *If $\tau_1\tau_2^{-1}$ is of infinite order and if one of the following holds*

- (a) $p \geq 5$ and $q \geq 5$,
- (b) $p \geq 4, q \geq 4$ and $r \neq 2$,
- (c) $p = r = 3$,

then the axis l of $\tau_1\tau_2^{-1}$ draws a figure eight loop in $S(p, q, r)$.

In this section, we are only interested in the cases above. Up to permutations of p, q, r , the cases $(3, q, 2)$ ($q \geq 7$), $(4, q, 2)$ ($q \geq 5$) are excluded among the (p, q, r) 's satisfying the hyperbolic condition: $\frac{1}{p} + \frac{1}{q} + \frac{1}{r} < 1$.

Now, we construct a Birkhoff section. Let ρ be the immersed geodesic loop which represents $\tau_1\tau_2^{-1}$. ρ divides $S(p, q, r)$ into two 1-gons and a 2-gon. We notice this 2-gon and denote it by R (see Figure 1). We choose a family C of convex smooth simple closed curves which fills the interior of R with one singularity Z deleted (see Figure 3). Let $S \subset M(p, q, r)$ be the closure of the set of unit vectors tangent to the curves belonging to C .

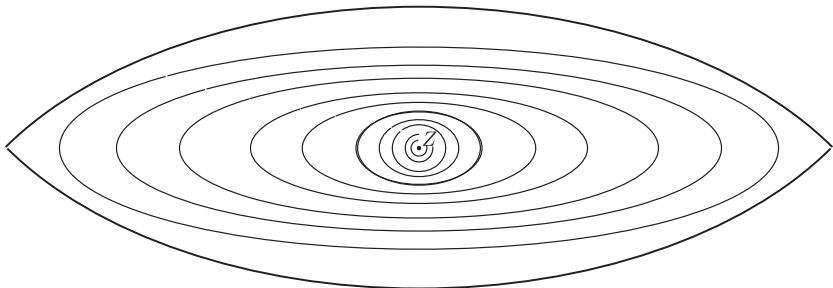

Fig. 3. R .

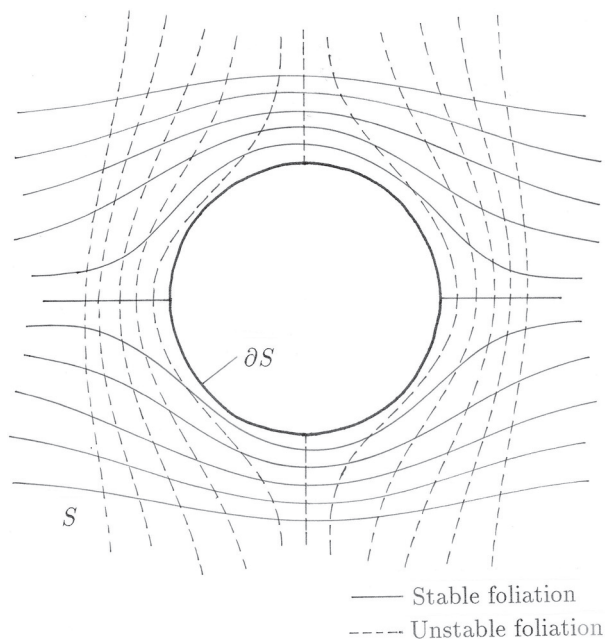

Fig. 4. The intersection of S and the foliations.

The next lemma is proved by the fact that the Euler characteristic of S is -2 and the convexity and the smoothness of the curves belonging to C .

Lemma 2.4. S satisfies the following.

- (1) S is diffeomorphic to the torus with two discs deleted. Boundary components are the closed geodesics ρ and $-\rho$. Here $-\rho$ represents $(\tau_1\tau_2^{-1})^{-1}$ in $\Gamma(p, q, r)$.
- (2) The interior $S - \partial S$ is transverse to F_t and the first return map for $S - \partial S$ extends to a diffeomorphism F of S .
- (3) $S - \partial S$ is also transverse to the stable foliation and the unstable foliation of F_t . The intersection of $S - \partial S$ and them is like Figure 4.

From the lemma above, we have the corollary below.

- Corollary 2.5.**
- (1) S is a Birkhoff section for F_t .
 - (2) F is semi-conjugate to a hyperbolic toral automorphism $\bar{A}_{p,q,r}$ induced by a hyperbolic matrix $A_{p,q,r} \in SL(2; \mathbf{Z})$. That is, there exists a continuous map $h: S \rightarrow T^2$ such that

- the image of each boundary component of S is a point of T^2 ,
- the restriction of h to $S - \partial S$ is a homeomorphism,
- $h \circ F = \bar{A}_{p,q,r} \circ h$.

Therefore, F_t is topologically constructed by two times $(1, 1)$ -Dehn surgeries to the suspension flow of $\bar{A}_{p,q,r}$ along its two closed orbits with period 1 [5].

2.3. Relations to the geodesic flows on the oriented closed surfaces

The geodesic flow on an oriented closed surface with constant negative curvature has Birkhoff sections which are punctured tori. And this flow is obtained by doing Dehn surgeries along closed orbits of suspension flows of hyperbolic toral automorphisms which are induced by hyperbolic matrices. In [9] and [3], two different Birkhoff sections are constructed and the corresponding hyperbolic matrices $A_g = \begin{pmatrix} 2g^2-1 & 2g(g-1) \\ 2g(g+1) & 2g^2-1 \end{pmatrix}$ and $B_g = \begin{pmatrix} 4g^2-2g-1 & 2g(g-1) \\ 8g^2-2 & 4g^2-2g-1 \end{pmatrix}$ are calculated.

In this section, we calculate $A_{2g+2,2g+2,g+1}$ and $A_{2g+1,2g+1,2g+1}$ from A_g and B_g ($g \geq 2$).

Lemma 2.6. *The oriented closed surface Σ_g with genus g ($g \geq 2$) is a $(2g+2)$ (resp. $(2g+1)$) -fold branched covering of $S(2g+2, 2g+2, g+1)$ (resp. $S(2g+1, 2g+1, 2g+1)$).*

Proof. To begin with, we construct a $(2g+2)$ -fold branched covering $\Sigma_g \rightarrow S(2g+2, 2g+2, g+1)$.

We consider a $(2g+2)$ -fold covering $\xi_g: \Sigma_{g,4} \rightarrow S_3^2$ where $\Sigma_{g,i}$ is Σ_g with i open discs deleted and S_i^2 is a 2-dimensional sphere S^2 with i open discs deleted. Attaching an open disc to each boundary components of $\Sigma_{g,4}$ and S_3^2 , and extending ξ_g , we obtain a branched covering $\hat{\xi}_g: \Sigma_g \rightarrow S(2g+2, 2g+2, g+1)$. To obtain a branched covering $\hat{\eta}_g: \Sigma_g \rightarrow S(2g+1, 2g+1, 2g+1)$, we begin a $(2g+1)$ -fold covering $\eta_g: \Sigma_{g,3} \rightarrow S_3^2$ (see Figure 5) and do the same construction as above. Q.E.D.

Then this branched covering induces a $(2g+2)$ (resp. $(2g+1)$)-fold covering

$$T_1 \hat{\xi}_g: T_1 \Sigma_g \rightarrow M(2g+2, 2g+2, g+1)$$

$$(\text{resp. } T_1 \hat{\eta}_g: T_1 \Sigma_g \rightarrow M(2g+1, 2g+1, 2g+1)).$$

Lemma 2.7. *If Σ_g is given a hyperbolic metric, then the geodesic flow on Σ_g is a lift of the geodesic flow on $S(2g+2, 2g+2, g+1)$ or $S(2g+1, 2g+1, 2g+1)$.*

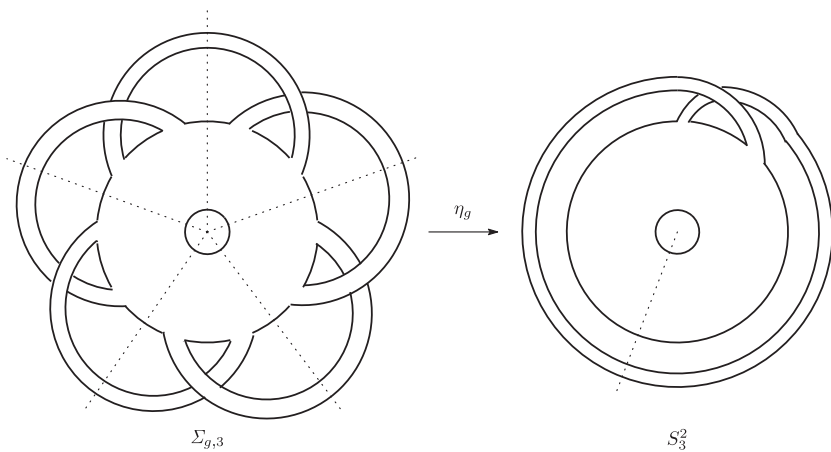

Fig. 5. $\eta_g : \Sigma_{g,3} \rightarrow S^2_3$.

Proof. These geodesic flows are induced from the geodesic flow on Poincaré disc through the covering maps

$$T_1 D^2 \longrightarrow T_1 D^2 / \pi_1(\Sigma_g) = T_1 \Sigma_g$$

$$\xrightarrow{T_1 \hat{\xi}_g} T_1 D^2 / \Gamma(2g + 2, 2g + 2, g + 1) = M(2g + 2, 2g + 2, g + 1),$$

or

$$T_1 D^2 \longrightarrow T_1 D^2 / \pi_1(\Sigma_g) = T_1 \Sigma_g$$

$$\xrightarrow{T_1 \hat{\eta}_g} T_1 D^2 / \Gamma(2g + 1, 2g + 1, 2g + 1) = M(2g + 1, 2g + 1, 2g + 1).$$

Q.E.D.

By this lemma, we can calculate $A_{2g+2, 2g+2, g+1}$ and $A_{2g+1, 2g+1, 2g+1}$ from A_g and B_g .

Theorem 2.8. (1) $A_{2g+2, 2g+2, g+1} = \begin{pmatrix} 2g^2-1 & g(g-1)(g+1) \\ 4g & 2g^2-1 \end{pmatrix}$,

(2) $A_{2g+1, 2g+1, 2g+1} = \begin{pmatrix} 4g^2-2g-1 & 2g(g-1)(2g+1) \\ 2(2g-1) & 4g^2-2g-1 \end{pmatrix}$.

Proof. We prove (1) at first.

$\tilde{S} = (T_1 \hat{\xi}_g)^{-1}(S)$ is the Birkhoff section for the geodesic flow on Σ_g which we used to calculate A_g [9].

\tilde{S} is constructed as follows. We divide Σ_g into four $(2g + 2)$ -gons. In the Poincaré disc D^2 shown in Figure 2, the fundamental region of

Σ_g consists of four $(2g + 2)$ -gons. We choose the two $(2g + 2)$ -gons containing Z or Z' , and fill them by convex smooth simple closed curves as in Subsection 2.2. \tilde{S} is the closure of the set of unit vectors tangent to these curves.

Let α be one of above convex smooth simple closed curves whose center is Z . We give α the counterclockwise orientation (see Figure 2). $\hat{\alpha}$ denotes the lift of α to S . Let β be the segment $Z'Z''$ and we lift β to the set $\hat{\beta}$ consisting of the unit tangent vectors orthogonal to $Z'Z''$ as shown in Figure 2. We take $\langle \hat{\alpha}, \hat{\beta} \rangle$ as a basis of \tilde{S} to calculate A_g . Let α' be the arc in α corresponding to the angle $Y'ZY$ and β' , the segment $Z'Z$. We take the lifts of α' and β' to S , denoted by $\hat{\alpha}'$ and $\hat{\beta}'$, as a basis of S . Then, the $(2g + 2)$ -fold covering $T_1\hat{\xi}_g|_{\tilde{S}}: \tilde{S} \rightarrow S$ maps $\hat{\alpha}$ onto $(g + 1)$ -fold $\hat{\alpha}'$ and $\hat{\beta}$ onto 2-fold $\hat{\beta}'$.

So, the $(2g + 2)$ -fold covering map $T_1\hat{\xi}_g|_{\tilde{S}}$ is induced from the matrix $\begin{pmatrix} g+1 & 0 \\ 0 & 2 \end{pmatrix}$. Hence,

$$\begin{aligned} A_{2g+2,2g+2,g+1} &= \begin{pmatrix} g+1 & 0 \\ 0 & 2 \end{pmatrix} A_g \begin{pmatrix} g+1 & 0 \\ 0 & 2 \end{pmatrix}^{-1} \\ &= \begin{pmatrix} 2g^2 - 1 & g(g^2 - 1) \\ 4g & 2g^2 - 1 \end{pmatrix}. \end{aligned}$$

As for (2), we remember Brunella's construction. In this case, Σ_g is divided into one $(4g + 2)$ -gon and two $(2g + 1)$ -gons. Hence, all $(4g + 2)$ -gons in the universal covering space of Σ_g , i.e. the Poincaré disc, are identified. So, the $(4g + 2)$ -gon containing Z and the one containing Z' in Figure 2 are identified in Σ_g . To construct the Birkhoff section, we fill the $(4g + 2)$ -gon by convex smooth simple closed curves and proceed as above. When we calculate B_g , we use the basis of \tilde{S} which are lifts of a convex smooth simple closed curve used above and the segment $Z'Z$ in Figure 2. The basis of S , $\langle \hat{\alpha}', \hat{\beta}' \rangle$, are the same as (1). Then, the $(2g + 1)$ -fold covering $\tilde{S} \rightarrow S$ maps $\hat{\alpha}$ onto $(2g + 1)$ -fold $\hat{\alpha}'$. Therefore,

$$\begin{aligned} A_{2g+1,2g+1,2g+1} &= \begin{pmatrix} 2g+1 & 0 \\ 0 & 1 \end{pmatrix} B_g \begin{pmatrix} 2g+1 & 0 \\ 0 & 1 \end{pmatrix}^{-1} \\ &= \begin{pmatrix} 4g^2 - 2g - 1 & 2g(g-1)(2g+1) \\ 2(2g-1) & 4g^2 - 2g - 1 \end{pmatrix}. \end{aligned}$$

Q.E.D.

Remark 2.9. By use of the notation in [4], the conjugacy classes of above matrices are as follows. Let X, Y be $\begin{pmatrix} 1 & 1 \\ 0 & 1 \end{pmatrix}, \begin{pmatrix} 1 & 0 \\ 1 & 1 \end{pmatrix}$ respectively. In

order to determine the conjugacy classes in $SL(2; \mathbf{Z})$, we slightly modify the method to determine the conjugacy classes in $GL(2; \mathbf{Z})$ [12].

- $A_{2g+1, 2g+1, 2g+1} \sim XY^{4g-4}XY^{2g-2}$. (This means that $A_{2g+1, 2g+1, 2g+1}$ is conjugate to $XY^{4g-4}XY^{2g-2}$.)
- $A_{2g+2, 2g+2, g+1} \sim X^{g-2}YX^{4g-2}Y$ if g is even and $g \geq 2$.
- $A_{2g+2, 2g+2, g+1} \sim (Y^2X^{g-1})^2$ if g is odd and $g \geq 3$.

Hence, the Birkhoff sections constructed here are different from Dehornoy’s sections on $S(2g+2, 2g+2, g+1)$ and $S(2g+1, 2g+1, 2g+1)$.

§3. Birkhoff sections for geodesic flows of 2-spheres with n -singularities

3.1. Construction with figure eight loops

In this subsection, let n be a positive integer greater than or equal to 4. Let $D(p_1, p_2, \dots, p_n)$ be a convex geodesic n -gon in Poincaré disc D^2 with vertexes $\tilde{X}_1, \tilde{X}_2, \dots, \tilde{X}_n$ with angles $\frac{\pi}{p_1}, \frac{\pi}{p_2}, \dots, \frac{\pi}{p_n}$ respectively (Figure 6). Then $n - 2 - \sum_{i=1}^n \frac{1}{p_i} > 0$. We choose a positive real number δ greater than the diameter of $D(p_1, \dots, p_n)$ and fix it.

Let σ_i be the reflection of D^2 in the side $\tilde{X}_i\tilde{X}_{i+1}$, where $n + 1$ describes 1. Let $\Gamma_*(p_1, \dots, p_n)$ denote the group of isometries generated by $\{\sigma_1, \dots, \sigma_n\}$, and $\Gamma(p_1, \dots, p_n)$ the orientation preserving subgroup of $\Gamma_*(p_1, \dots, p_n)$. The double of the n -gon gives rise to a hyperbolic 2-sphere $S(p_1, p_2, \dots, p_n)$ with singularities X_1, X_2, \dots, X_n whose cone angles are $\frac{2\pi}{p_1}, \frac{2\pi}{p_2}, \dots, \frac{2\pi}{p_n}$ respectively, that is to say $S(p_1, \dots, p_n) =$

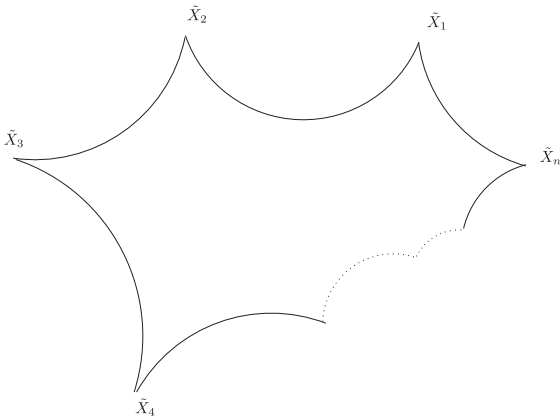

Fig. 6. n -gon $D(p_1, p_2, \dots, p_n)$.

$D^2/\Gamma(p_1, \dots, p_n)$. We denote the universal covering map as orbifold $D^2 \rightarrow S(p_1, \dots, p_n)$ by π . Then D^2 has a natural cell complex structure \mathcal{C} which consists of the vertexes $\sigma(\tilde{X}_i)$, the edges $\sigma(\tilde{X}_i)\sigma(\tilde{X}_{i+1})$, and the faces $\sigma(\text{int}(D(p_1, \dots, p_n)))$, where $\text{int}(B)$ denotes the interior of a region B . A face $\sigma(\text{int}(D(p_1, \dots, p_n)))$ is called to be *right* (resp. *wrong*) if σ belongs to $\Gamma(p_1, \dots, p_n)$ (resp. $\Gamma_*(p_1, \dots, p_n) - \Gamma(p_1, \dots, p_n)$).

Suppose we are given a unit speed geodesic $\gamma(t)$ and real numbers a, b with $a < b$. Then we say that $\gamma(a, b)$ traverses a geodesic segment α if there exist a number $t_0 \in (a, b)$ such that $\gamma(t_0)$ is an inner point of the segment α and $\gamma(a, b)$ and α transversely intersect at $\gamma(t_0)$. And we say that $\gamma(a, b)$ positively traverses an edge e of \mathcal{C} if there exists $t_0 \in (a, b)$ such that $\gamma(a, b)$ traverses e through $\gamma(t_0)$ and $\gamma(t_0 - \epsilon, t_0)$ is contained in the right face connecting to e for any sufficiently small $\epsilon > 0$. In that case, $\gamma(t_0 + \epsilon)$ is automatically contained in the wrong face connecting to e for sufficiently small $\epsilon > 0$.

Suppose we are given an embedded convex geodesic k -gon $R(X_i)$ in $S(p_1, p_2, \dots, p_n)$ which contains a unique singularity X_i in its interior and does not the other singularities. We choose a family $C(X_i)$ of smooth convex simple closed curves which fills $R(X_i) - \{X_i\}$ and gives rise to a one-dimensional foliation. We also take an orientation $\mathcal{O}(X_i)$ of the foliation. Then, let $\Sigma(X_i)$ be the closure of the set of the unit vectors tangent to the foliation $C(X_i)$ with the direction $\mathcal{O}(X_i)$. Further, suppose we are given a vertex \tilde{Q} of \mathcal{C} . Then we denote by $\tilde{R}(\tilde{Q})$ the connected component of $\pi^{-1}(R(Q))$ containing \tilde{Q} , where $Q = \pi(\tilde{Q})$. Further, we denote by $\tilde{C}(\tilde{Q})$ the restriction of the induced foliation $\pi^*(C(Q))$ to $\tilde{R}(\tilde{Q})$. We give the foliation $\tilde{C}(\tilde{Q})$ the orientation induced by $\mathcal{O}(Q)$, which is denoted by $\tilde{\mathcal{O}}(\tilde{Q})$.

Theorem 3.1. *Let $S(p_1, p_2, \dots, p_n)$ be as above. If $p_i \geq 4$ for any i ($1 \leq i \leq n$), the geodesic flow of $S(p_1, p_2, \dots, p_n)$ has a genus one Birkhoff section.*

Before the proof, we will prove the following technical lemma.

Lemma 3.2. *Let γ be a unit speed geodesic and a, b real numbers with $b - a \geq 2\delta$. If $\gamma(a, b)$ contains no vertexes of \mathcal{C} , there exists an edge e of \mathcal{C} such that $\gamma(a, b)$ positively traverses e .*

Proof. Since the diameter of each face of \mathcal{C} is less than δ , there exist $t_1 \in (a, a + \delta)$ and an edge e_1 of \mathcal{C} such that $\gamma(t_1) \in e_1$. By the way of choice of δ , a and b , if $\gamma(a, b)$ contains an open subsegment of an edge e_1 , it contains at least one of the vertexes of e_1 . By the assumption of this lemma, the case does not occur. Then $\gamma(a, a + \delta)$ traverses e_1 through $\gamma(t_1)$ for some t_1 . And there exists the face F of \mathcal{C} connecting

to e_1 such that, for any sufficiently small $\epsilon > 0$, $\gamma((t_1, t_1 + \epsilon)) \subset F$. If F is a wrong face, e_1 is the required edge.

We consider the case that F is a right face. We define a real number t_2 by

$$t_2 = \{t \in (t_1, t_1 + \delta) \mid \gamma(t) \in F\}.$$

Since the diameter of F is less than δ , we can see that $t_2 < t_1 + \delta < b$ and that $\gamma(t_2)$ is contained in an edge e_2 connected by F . By using the same argument for e_1 , we can see that $\gamma(t_1, t_1 + \delta)$ positively traverses e_2 through $\gamma(t_2)$. Q.E.D.

Proof of Theorem 3.1. Suppose an integer i ($1 \leq i \leq n$) is fixed. We can easily see that there exist geodesic segments α, β such that

- (1) α starts from an interior point of the edge $\tilde{X}_{i-1}\tilde{X}_i$ and arrives at the point $\tilde{X}_{i+1} = \sigma_i(\tilde{X}_{i+1})$,
- (2) β starts from an interior point of the edge $\tilde{X}_{i-1}\tilde{X}_i$ and arrives at the point $\sigma_i(\tilde{X}_{i+2})$, and
- (3) both α and β is perpendicular to the edge $\tilde{X}_{i-1}\tilde{X}_i$.

(See Figure 7.) Let θ_α (resp. θ_β) denote the angle between α (resp. β) and $\sigma_i(\tilde{X}_{i+1}\tilde{X}_{i+2})$ as in Figure 7. Since every p_j is greater than or equal to 4, we have $\theta_\alpha < \frac{\pi}{2}$ and $\theta_\beta > \frac{\pi}{2}$. Then there exists a unique oriented geodesic segment γ_i in D^2 such that

- (1) γ_i starts from a point of the edge $\tilde{X}_{i-1}\tilde{X}_i$,
- (2) γ_i arrives at a point of the edge $\sigma_i(\tilde{X}_{i+1}\tilde{X}_{i+2})$,
- (3) γ_i is perpendicular to edges $\tilde{X}_{i-1}\tilde{X}_i, \sigma_i(\tilde{X}_{i+1}\tilde{X}_{i+2})$ respectively.

Let $\bar{\gamma}_i$ be the oriented geodesic $-\sigma_i(\gamma_i)$, where the minus means that the orientation is reversed. Then the union $\gamma_i \cup \bar{\gamma}_i$ gives rise to a closed oriented geodesic η_i in $S(p_1, p_2, \dots, p_n)$ which draws an oriented figure eight loop. The closed curve η_i cut out two 1-gons $R_i(X_i), R_i(X_{i+1})$ which contains a singularity X_i, X_{i+1} respectively. Choose families $C_i(X_i), C_i(X_{i+1})$ of smooth convex closed curves in $R_i(X_i), R_i(X_{i+1})$ respectively as described above. We can determine the orientations of the foliations $C_i(X_i)$ and $C_i(X_{i+1})$ from the orientation of the loop η_i . We can obtain the surfaces $\Sigma_i(X_i), \Sigma_i(X_{i+1})$ from the oriented foliations $C_i(X_i), C_i(X_{i+1})$ respectively by the construction described before the theorem. Now, we define the surface by

$$S = \bigcup_{i=1}^n (\Sigma_i(X_i) \cup \Sigma_i(X_{i+1})).$$

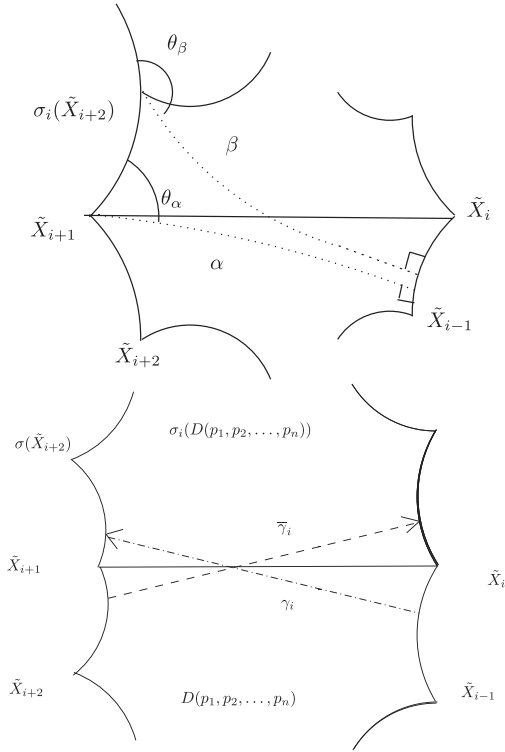

Fig. 7. Existence of figure eight loops.

And we will show that S is a genus one Birkhoff section for the geodesic flow of $S(p_1, p_2, \dots, p_n)$.

We can see that $\Sigma_i(X_i) \cup \Sigma_i(X_{i+1})$ is homeomorphic to a sphere with three holes, and that the boundary of $\Sigma_i(X_i) \cup \Sigma_i(X_{i+1})$ consists of $(T_1S(p_1, \dots, p_n))_{X_i}$, $(T_1S(p_1, \dots, p_n))_{X_{i+1}}$, and the periodic orbit determined by the oriented closed geodesic η_i . Then the Euler characteristic of S equals $-n$, and S has n boundary components. Thus we can see that S is of genus one.

To complete the proof, it suffices to show that S is a Birkhoff section. And we will check that S satisfies the conditions (1), (2) and (3) in the definition of Birkhoff section.

Condition (1) Convexity of curves in $C_i(X_i)$ and $C_i(X_{i+1})$ guarantees that geodesic flow transversely intersects the interior of S .

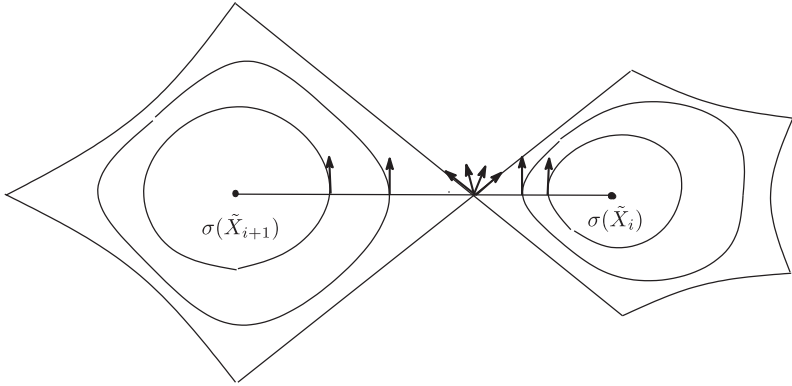

Fig. 8. Convex curves and its tangent vectors near the edge $\sigma(\tilde{X}_i)\sigma(\tilde{X}_{i+1})$.

Condition (2) The boundary of S consists of n periodic orbits corresponding to η_i ($i = 1, \dots, n$).

Condition (3) Let (X, v) be a point of $T_1S(p_1, \dots, p_n)$ and $\gamma(t)$ a geodesic with initial conditions $\gamma(0) = X$ and $\gamma'(0) = v$. We take any lifts $(\tilde{X}, \tilde{v}) \in T_1D^2$ of (X, v) and $\tilde{\gamma}(t)$ of $\gamma(t)$ with initial conditions $\tilde{\gamma}(0) = \tilde{X}$ and $\tilde{\gamma}'(0) = \tilde{v}$. Since the constant δ does not depend on the choice of initial data (X, v) , it suffices to show that $\hat{\gamma}(0, 6\delta)$ meets \tilde{S} , where $\hat{\gamma}(t) = (\tilde{\gamma}(t), \tilde{\gamma}'(t))$.

For any vertex \tilde{Q} of \mathcal{C} , we have $(T_1D^2)_{\tilde{Q}} \subset \tilde{S}$. Then, if $\tilde{\gamma}(2\delta, 4\delta)$ contains a vertex of \mathcal{C} , $\hat{\gamma}(2\delta, 4\delta)$ meets \tilde{S} .

Suppose that $\tilde{\gamma}(2\delta, 4\delta)$ contains no vertexes. By Lemma 3.2, there exists a real number $t_0 \in (2\delta, 4\delta)$, two vertexes \tilde{Q}_1, \tilde{Q}_2 of \mathcal{C} such that $\tilde{\gamma}(2\delta, 4\delta)$ positively traverses the edge $\tilde{Q}_1\tilde{Q}_2$ through $\tilde{\gamma}(t_0)$. Then there exist vertexes $\tilde{X}_i, \tilde{X}_{i+1}$ and an element $\sigma \in \Gamma(p_1, \dots, p_n)$ such that $\tilde{Q}_1 = \sigma(\tilde{X}_i)$ and $\tilde{Q}_2 = \sigma(\tilde{X}_{i+1})$. Since, for any vertex \tilde{Q} of \mathcal{C} , the diameter of $\tilde{R}_j(\tilde{Q})$ is less than 2δ , both $\tilde{\gamma}(0)$ and $\tilde{\gamma}(6\delta)$ are located outside one of $Cl(\tilde{R}_i(\tilde{Q}_1))$ and $Cl(\tilde{R}_i(\tilde{Q}_2))$, where $Cl(B)$ denotes the closure of B . Then we can see that one of the following occurs. (See Figure 8.)

- (a) $\tilde{\gamma}(0, 6\delta)$ is tangent to a convex curve which is a leaf of $\tilde{C}(\tilde{Q}_1)$ or $\tilde{C}(\tilde{Q}_2)$. And at the tangent point, the velocity vector of $\tilde{\gamma}(t)$ and the unit vector determined by $\tilde{O}_i(\tilde{Q}_1)$ and $\tilde{O}_i(\tilde{Q}_2)$ are the same.
- (b) Any sufficiently small perturbation of the oriented geodesic segment $\tilde{\gamma}(0, 6\delta)$ not through $\tilde{\gamma}(t_0)$ is tangent to a convex curve

which is a leaf of $\tilde{C}(\tilde{Q}_1)$ or $\tilde{C}(\tilde{Q}_2)$. And at the tangent point, the velocity vector of the perturbed segment and the unit vector determined by $\tilde{O}_i(\tilde{Q}_1)$ and $\tilde{O}_i(\tilde{Q}_2)$ are the same.

Then $\hat{\gamma}(0, 6\delta)$ meets \tilde{S} , which means that every geodesic flow line starting at any point of T_1D^2 meets \tilde{S} in the bounded time 6δ . This completes the proof. Q.E.D.

3.2. Construction with simple loops and geodesic segments connecting two singularities with angle π

In this subsection, let $n = 2m$ be an even positive integer greater than or equal to 6. Let $D(p_1, p_2, \dots, p_n)$ be a convex geodesic n -gon in Poincaré disc D^2 with vertexes $\tilde{X}_1, \tilde{X}_2, \dots, \tilde{X}_n$ with angles $\frac{\pi}{p_1}, \frac{\pi}{p_2}, \dots, \frac{\pi}{p_n}$ respectively. Here, we assume that $p_1 \leq p_3 \leq \dots \leq p_{2m-1} \leq p_2 \leq p_4 \leq \dots \leq p_{2m}$. For any integer $2k$ ($1 \leq k \leq m$), we define a surfaces $\Sigma_{2k}(X_{2k-1}), \Sigma_{2k}(X_{2k+1})$ as follows.

First, we consider the case of $p_{2k} = 2$. Then, we have $p_{2k-1} = p_{2k} = p_{2k+1} = 2$ by the assumption above. We take oriented geodesic segments $\tilde{X}_{2k}\tilde{X}_{2k-1}, \tilde{X}_{2k+1}\tilde{X}_{2k}$ in D^2 , which induce geodesic segments $X_{2k}X_{2k-1}, X_{2k+1}X_{2k}$ in $S(p_1, p_2, \dots, p_n)$ respectively. Now let $\Sigma_{2k}(X_{2k-1})$ (resp. $\Sigma_{2k}(X_{2k+1})$) be the closure of the set of unit vectors at points of $X_{2k}X_{2k-1}$ (resp. $X_{2k+1}X_{2k}$) which points to the left side of the oriented geodesic segment $X_{2k}X_{2k-1}$ (resp. $X_{2k+1}X_{2k}$).

Next, we consider the case of $p_{2k} > 2$. There are oriented geodesic segment γ_{2k}^- (resp. γ_{2k}^+) in $D(p_1, p_2, \dots, p_n)$ such that

- (1) γ_{2k}^- (resp. γ_{2k}^+) starts from a point of the edge $\tilde{X}_{2k-2}\tilde{X}_{2k-1}$ (resp. $\tilde{X}_{2k+1}\tilde{X}_{2k+2}$),
- (2) γ_{2k}^- (resp. γ_{2k}^+) arrives at a point of the edge $\tilde{X}_{2k}\tilde{X}_{2k+1}$ (resp. $\tilde{X}_{2k-1}\tilde{X}_{2k}$),
- (3) γ_{2k}^- (resp. γ_{2k}^+) is perpendicular to edges $\tilde{X}_{2k-2}\tilde{X}_{2k-1}, \tilde{X}_{2k}\tilde{X}_{2k+1}$ (resp. $\tilde{X}_{2k+1}\tilde{X}_{2k+2}, \tilde{X}_{2k-1}\tilde{X}_{2k}$) respectively.

(See Figure 9.) Let $\bar{\gamma}_{2k}^-, \bar{\gamma}_{2k}^+$ be the oriented geodesic segments $-\sigma_{2k-1}(\gamma_{2k}^-), -\sigma_{2k}(\gamma_{2k}^+)$ respectively. Then the union $\gamma_{2k}^- \cup \bar{\gamma}_{2k}^-$ (resp. $\gamma_{2k}^+ \cup \bar{\gamma}_{2k}^+$) gives rise to a simple closed oriented geodesic η_{2k}^- (resp. η_{2k}^+) of $S(p_1, p_2, \dots, p_{2m})$. The union $\eta_{2k}^- \cup \eta_{2k}^+$ divides $S(p_1, p_2, \dots, p_{2m})$ into four 2-gons. Take a unique 2-gon $R_{2k}(X_{2k-1})$ (resp. $R_{2k}(X_{2k+1})$) which contains a singularity X_{2k-1} (resp. X_{2k+1}). Then we can apply the construction in Subsection 3.1 to these 2-gons $R_{2k}(X_{2k-1}), R_{2k}(X_{2k+1})$, and obtain the surfaces $\Sigma_{2k}(X_{2k-1}), \Sigma_{2k}(X_{2k+1})$ respectively. Now we can prove the following theorem.

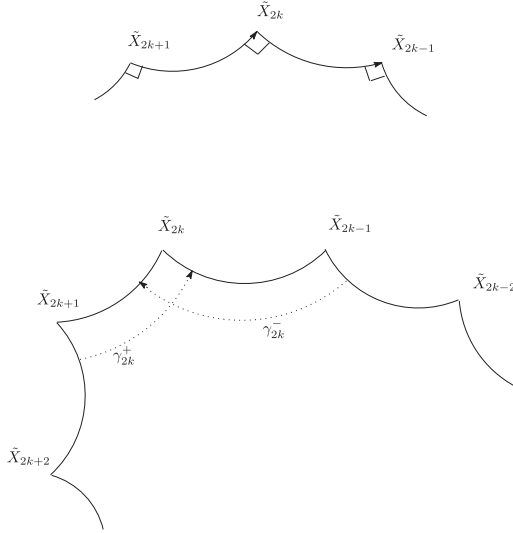

Fig. 9. Geodesic segments.

Theorem 3.3. *If $S(p_1, p_2, \dots, p_{2m})$ be as above, the geodesic flow of $S(p_1, p_2, \dots, p_{2m})$ has a genus one Birkhoff section.*

Before the proof, we will prove the following technical lemma.

Lemma 3.4. *Let $\gamma(t)$ be a unit speed geodesic and a, b real numbers with $b - a \geq 6\delta$. If $\gamma(a, b)$ contains no vertexes of \mathcal{C} , there exist vertexes $\tilde{X}_{2i-1}, \tilde{X}_{2i+1}$ of \mathcal{C} and an element $\sigma \in \Gamma_*(p_1, \dots, p_n)$ such that $\gamma(a, b)$ traverses the diagonal edge $\sigma(\tilde{X}_{2i-1})\sigma(\tilde{X}_{2i+1})$ of $\sigma(D(p_1, \dots, p_n))$.*

Proof. Let G_{odd} be a graph in D^2 consisting of the vertexes $\sigma(\tilde{X}_{2k-1})$ and the edges $\sigma(\tilde{X}_{2k-1})\sigma(\tilde{X}_{2k+1})$, where $k \in \{1, \dots, m\}$, $\sigma \in \Gamma_*(p_1, \dots, p_n)$, and $\sigma(\tilde{X}_{2k-1})\sigma(\tilde{X}_{2k+1})$ denotes the geodesic segment between $\sigma(\tilde{X}_{2k-1})$ and $\sigma(\tilde{X}_{2k+1})$. Note that $2n + 1$ describes 1 and $\sigma(\tilde{X}_{2k-1})\sigma(\tilde{X}_{2k+1})$ is a diagonal of n -gon $\sigma(D(p_1, \dots, p_n))$. Then every connected component $D^2 - G_{odd}$ is an interior of a convex geodesic j -gon for some $j \in \{2p_1, \dots, 2p_n, n\}$, and has the diameter less than 2δ . Then there exists $t_0 \in (\delta, 3\delta)$ such that $\tilde{\gamma}(t_0) \in G_{odd}$. Since $\tilde{\gamma}(\delta, 3\delta)$ contains no vertex of G_{odd} , $\tilde{\gamma}(t_0)$ is not a vertex of G_{odd} . Then there exists an edge e of G_{odd} such that e contains $\tilde{\gamma}(t_0)$ in its interior. Since the length of e is less than δ , if e is contained in $\tilde{\gamma}(\mathbf{R})$, it is contained in $\tilde{\gamma}(0, 4\delta)$, so the vertexes of e are. Since $\tilde{\gamma}(\delta, 3\delta)$ contains no vertex

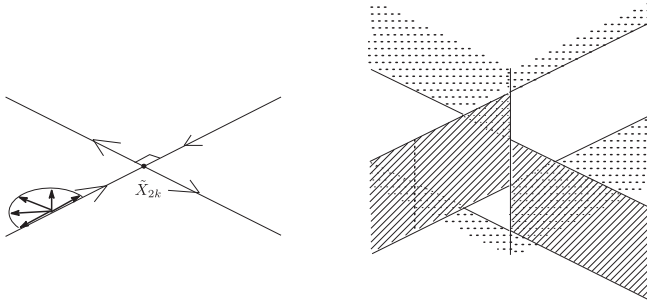

Fig. 10. A local picture of the universal lift of $\Sigma_{2k}(X_{2k-1}) \cup \Sigma_{2k}(X_{2k+1})$. See [4] for more details.

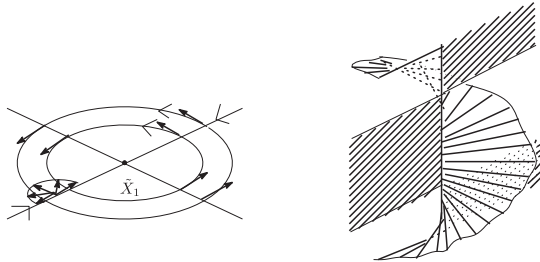

Fig. 11. A local picture of the universal lift of $\Sigma_2(X_1) \cup \Sigma_n(X_1)$ in the case $p_2 = 2$ and $p_n \geq 3$. See Figure 12, in which the picture about $\Sigma_2(X_3) \cup \Sigma_4(X_3)$ is like the picture above in shape.

of G_{odd} , the case does not occur. Therefore, $\tilde{\gamma}(0, 4\delta)$ traverses e , and this completes the proof. Q.E.D.

Proof of Theorem 3.3. We define a surface S by

$$S = \bigcup_{k=1}^m (\Sigma_{2k}(X_{2k-1}) \cup \Sigma_{2k}(X_{2k+1})).$$

By using Figure 14, we see that the Euler characteristic of S equals $(-2) \times m = -n$ and S has $2m = n$ boundary components. Thus we can see that S is of genus one. Further, we can see that the surface S gives rise to a Birkhoff section for the geodesic flow of $S(p_1, p_2, \dots, p_{2m})$ in a similar fashion of the proof of Theorem 3.1 by using Figure 12 and

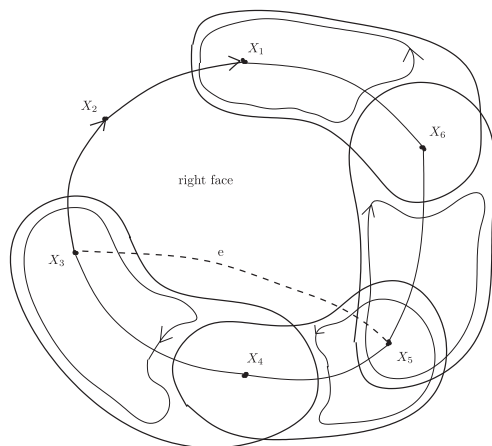

Fig. 12. Around the diagonal on the right face.

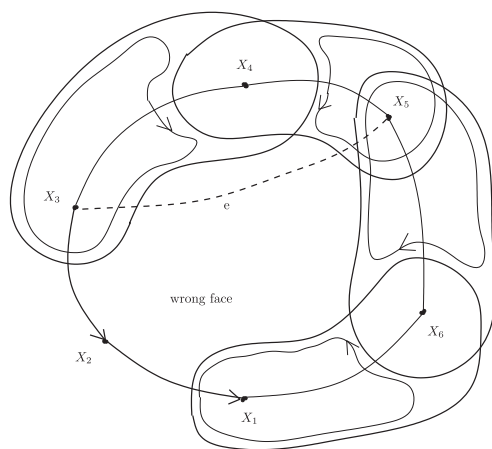
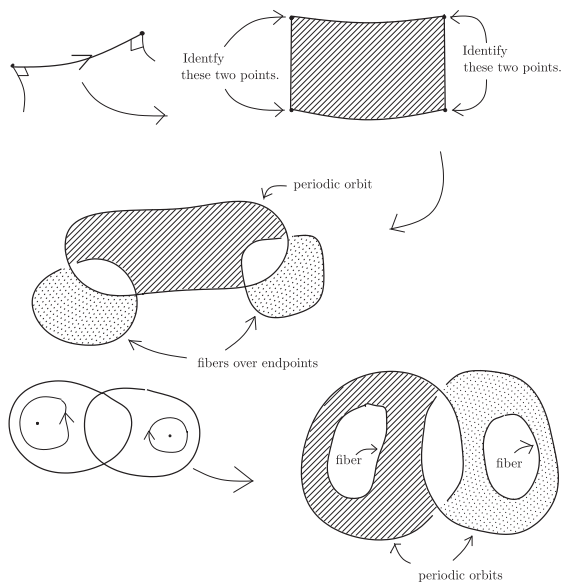

Fig. 13. Around the diagonal on the wrong face.

Figure 13. Note that both Figure 12 and Figure 13 show the case of $p_1 = p_2 = p_3 = p_5 = 2$, $p_4 \geq 3$ and $p_6 \geq 3$. Q.E.D.

Fig. 14. Topologies of the parts of S .

References

- [1] D. V. Anosov, *Geodesic flows on closed Riemann manifolds with negative curvature*, Proceedings of the Steklov Institute of Mathematics **90**, Amer. Math. Soc., Providence, RI, 1969.
- [2] G. D. Birkhoff, Dynamical systems with two degrees of freedom, *Trans. Amer. Math. Soc.* **18** (1917), 199–300.
- [3] M. Brunella, On the discrete Godbillon–Vey invariant and Dehn surgery on geodesic flows, *Ann. Fac. Sci. Toulouse Math.* (6) **3** (1994), 335–344.
- [4] P. Dehornoy, Genus one Birkhoff sections for geodesic flows, arXiv:1208.6405v2, to appear in *Ergodic Theory Dynam. Systems*.
- [5] D. Fried, Transitive Anosov flows and pseudo-Anosov maps, *Topology* **22** (1983), 299–303.
- [6] J. Franks and B. Williams, Anomalous Anosov flows, in *Global theory of dynamical systems (Proc. Internat. Conf., Northwestern Univ., Evanston, Ill., 1979)*, Lecture Notes in Math. **819**, Springer, Berlin, 1980, 158–174.
- [7] É. Ghys, Sur l’invariance topologique de la classe de Godbillon–Vey, *Ann. Inst. Fourier (Grenoble)* **37** (1987), 59–76.

- [8] S. Goodman, Dehn surgery on Anosov flows, in *Geometric dynamics (Rio de Janeiro, 1981)*, Lecture Notes in Math. **1007**, Springer, Berlin, 1983, 300–307.
- [9] N. Hashiguchi, On the Anosov diffeomorphisms corresponding to geodesic flows on negatively curved closed surfaces, *J. Fac. Sci. Univ. Tokyo Sect. IA Math.* **37** (1990), 485–494.
- [10] N. Hashiguchi, PL-representations of Anosov foliations, *Ann. Inst. Fourier (Grenoble)* **42** (1992), 937–965.
- [11] J. Milnor, On the 3-dimensional Brieskorn manifolds $M(p, q, r)$, in *Knots, groups, and 3-manifolds (Papers dedicated to the memory of R. H. Fox)*, Ann. of Math. Studies **84**, Princeton Univ. Press, Princeton, NJ, 1975, 175–225.
- [12] K. Sakamoto and S. Fukuhara, Classification of T^2 -bundles over T^2 , *Tokyo J. Math.* **6** (1983), 311–327.
- [13] P. Scott, There are no fake Seifert fibre spaces with infinite π_1 , *Ann. of Math. (2)* **117** (1983), 35–70.
- [14] A. Verjovsky, Codimension one Anosov flows, *Bol. Soc. Mat. Mexicana (2)* **19** (1974), 49–77.

Norikazu Hashiguchi
Department of Mathematics
College of Science and Technology
Nihon University
Kanda-Surugadai, Chiyoda-ku
Tokyo 101-8303
Japan
E-mail address: nhashi@math.cst.nihon-u.ac.jp

Hiroyuki Minakawa
Faculty of Education, Art and Science
Yamagata University
Kojirakawa-machi 1-4-12
Yamagata 990-8560
Japan
E-mail address: ep538@kdeve.kj.yamagata-u.ac.jp