

Rank two affine submanifolds in $\mathcal{H}(2, 2)$ and $\mathcal{H}(3, 1)$

DAVID AULICINO
DUC-MANH NGUYEN

We classify all rank two affine manifolds in strata in genus three with two zeros. This confirms a conjecture of Maryam Mirzakhani in these cases. Several technical results are proven for all strata in genus three, with the hope that they may shed light on a complete classification of rank two manifolds in genus three.

32G15; 14H10

1 Introduction

The action of $GL^+(2, \mathbb{R})$ on the moduli space of translation surfaces has been studied extensively from both dynamical and geometric perspectives. However, until recently, the nature of $GL^+(2, \mathbb{R})$ -orbit closures was very mysterious. The recent breakthrough of Eskin and Mirzakhani [5] and Eskin, Mirzakhani and Mohammadi [6] proved that all $GL^+(2, \mathbb{R})$ -orbit closures are affine invariant submanifolds, thereby demonstrating that these objects possess a very nice structure. This result tremendously changed the nature of the field and facilitated several more breakthroughs on their properties; see Avila, Eskin and Moeller [3], Filip [7; 8] and Wright [17; 18].

In particular, Wright [18] introduced the (cylinder) rank of an affine manifold, defined as half the dimension of its tangent space projected to absolute cohomology. Furthermore, in [17] he introduced the field of affine definition of an affine manifold, which corresponds to the smallest (real) field in which the coefficients of the local systems of linear equations defining the affine manifold lie. If this field is \mathbb{Q} , then the affine manifold is said to be *arithmetic*.

It was well known that the translation surfaces in an arithmetic rank one manifold are always given by branched coverings of tori (a formal proof of this can be found in Aulicino [1]), so that the rank one manifold itself is a covering of a stratum of marked tori. Maryam Mirzakhani conjectured that a similar result should hold for higher rank affine manifolds.

Conjecture (Mirzakhani) *Let \mathcal{M} be an affine manifold in a stratum of translation surfaces. If $\text{rank}(\mathcal{M}) \geq 2$ and $k(\mathcal{M}) = \mathbb{Q}$, then \mathcal{M} is either the entire stratum or a covering of a stratum of abelian or quadratic differentials.*

A rank two affine invariant submanifold in genus three is always arithmetic by [17, Theorem 1.5].

This conjecture was already known to be true in genus two due to the work of McMullen [12]. The first results in higher genus were due to Nguyen and Wright [15] and Auricino, Nguyen and Wright [2], and they affirmed this conjecture in genus three for the two connected components of the stratum $\mathcal{H}(4)$: $\mathcal{H}^{\text{hyp}}(4)$ and $\mathcal{H}^{\text{odd}}(4)$, respectively. We use these results as a starting point toward the goal of classifying all higher rank affine manifolds in genus three. In this paper, we classify all rank two affine manifolds in strata in genus three with two zeros, and our results affirm Mirzakhani’s conjecture. Before stating our results, we recall the classification of connected components of strata in genus three with at most two zeros, due to Kontsevich and Zorich:

Theorem [10, Theorem 2] *The connected components of strata in genus three with at most two zeros are given in the following diagram, where a line indicates that one connected component lies in the boundary of another:*

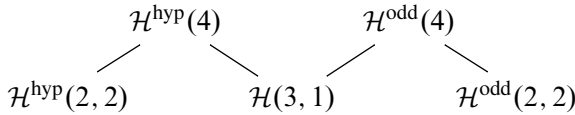

In this paper, we prove:

Theorem 1.1 *Let \mathcal{M} be a rank two affine manifold in genus three.*

- *If $\mathcal{M} \subset \mathcal{H}^{\text{hyp}}(2, 2)$, then $\mathcal{M} = \tilde{\mathcal{Q}}(1^2, -1^2) = \tilde{\mathcal{H}}_{(2,2)}^{\text{hyp}}(2)$.*
- *If $\mathcal{M} \subset \mathcal{H}^{\text{odd}}(2, 2)$, then $\mathcal{M} = \tilde{\mathcal{Q}}(4, -1^4)$ or $\mathcal{M} = \tilde{\mathcal{H}}_{(2,2)}^{\text{odd}}(2) \subset \tilde{\mathcal{Q}}(4, -1^4)$.*

Here $\tilde{\mathcal{H}}_{(2,2)}^{\text{hyp}}(2)$ and $\tilde{\mathcal{H}}_{(2,2)}^{\text{odd}}(2)$ are the loci of unramified double covers of abelian differentials in $\mathcal{H}(2)$ in the components $\mathcal{H}^{\text{hyp}}(2, 2)$ and $\mathcal{H}^{\text{odd}}(2, 2)$, respectively. They are both 4-complex dimensional. The loci $\tilde{\mathcal{Q}}(1^2, -1^2)$ and $\tilde{\mathcal{Q}}(4, -1^4)$ consist of the standard orienting double covers of quadratic differentials in the strata $\mathcal{Q}(1^2, -1^2)$ and $\mathcal{Q}(4, -1^4)$, respectively. They have complex dimensions four and five, respectively. It turns out that $\tilde{\mathcal{Q}}(1^2, -1^2)$ and $\tilde{\mathcal{H}}_{(2,2)}^{\text{hyp}}(2)$ coincide.

There are no rank two affine manifolds in $\mathcal{H}(3, 1)$.

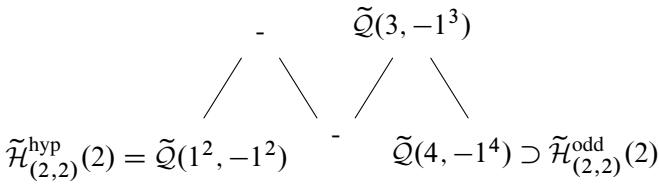

Figure 1: Rank two affine manifolds in genus three

Remark 1.2 In the above theorem, if p denotes the canonical projection from relative to absolute cohomology, then the kernel of p is 0-dimensional for all of the 4-dimensional loci above, and it is 1-dimensional for all of the 5-dimensional loci. The dimension of the kernel of p is commonly known as the “dimension of rel”.

Theorem 1.1 summarizes Theorems 6.4 and 6.11, Lemma 6.12, and Theorem 6.13.

Remarks 1.3 • It follows from Lanneau [11] that $\tilde{Q}(1^2, -1^2)$ and $\tilde{Q}(4, -1^4)$ are connected. Theorem 1.1 implies in particular that $\tilde{\mathcal{H}}_{(2,2)}^{\text{odd}}(2)$ is connected.

• Let S be a (compact) Riemann surface of genus two. An unramified double cover of S corresponds to a (normal) subgroup of index two of $\pi_1(S)$, which can be viewed as the kernel of a nonzero morphism from $\pi_1(S)$ to $\mathbb{Z}/2\mathbb{Z}$. Let x_0 be a Weierstrass point of S and let $\text{Mod}(S, x_0)$ denote the group of isotopy classes of homeomorphisms of S fixing x_0 . The existence of two components of unramified double covers of surfaces in $\mathcal{H}(2)$ is in accordance with the fact that the action of $\text{Mod}(S, x_0)$ on $H^1(S, \mathbb{Z}/2\mathbb{Z}) \setminus \{0\}$ has two orbits (see Nguyen [14, Lemma 3.3]).

We recall the main results of [15; 2]:

Theorem 1.4 [15; 2] *If \mathcal{M} is a rank two affine manifold in $\mathcal{H}(4)$, then $\mathcal{M} = \tilde{Q}(3, -1^3) \subset \mathcal{H}^{\text{odd}}(4)$. Here $\tilde{Q}(3, -1^3)$ is the set of standard double covers of quadratic differentials in $\mathcal{Q}(3, -1^3)$.*

Following the diagram of the strata of abelian differentials given in the theorem by Kontsevich and Zorich, we summarize all of the known classifications of rank two affine manifolds in genus three in Figure 1.

Though the primary goal of this paper is to prove a theorem about strata of translation surfaces in genus three with exactly two cone points, various results in this paper are established in various degrees of generality with the hope that they will lead to a classification of all higher rank affine manifolds in genus three. There are several

key techniques that are new to this paper that have not been used in the previous classifications of affine manifolds mentioned above. We highlight the two general techniques concerning affine invariant submanifolds, and then we highlight the strategy to approach the overwhelming combinatorics of the problem.

Affine manifold techniques First, both [15] and [2] heavily relied on the use of Smillie and Weiss [16] to find a horizontally periodic translation surface in every orbit closure. However, this was not sufficient for our purposes because when we find a translation surface with a “partially periodic” foliation (in the sense that there are horizontal cylinders, but they do not fill the surface) and some desirable properties, then we would like to preserve these properties while moving to a translation surface that is horizontally periodic. Unfortunately, [16] does not directly facilitate this because it requires flowing by the horocycle flow for an unspecified amount of time, resulting in a loss of certain crucial information.

To remedy this problem, we use the fact that the affine invariant submanifold \mathcal{M} is arithmetic, which implies that square-tiled surfaces are dense in \mathcal{M} . This allows us to perturb in an arbitrarily small neighborhood in order to find a square-tiled surface with the desired properties (see Proposition 2.9). This provides an additional benefit because square-tiled surfaces are Veech surfaces. In particular, this implies that every direction that admits a saddle connection is periodic. This tool will be used throughout the paper; see Lemma 3.2 and Propositions 4.8 and 5.8.¹

The second general technique is to use degenerations of translation surfaces. Degenerating a translation surface in \mathcal{M} by collapsing an equivalence class of cylinders so that exactly two zeros collide, but no closed curve pinches, results in a translation surface that lies in an affine manifold of equal rank in a lower dimensional stratum; see Proposition 2.16. This allows for a significant departure from the techniques of [15; 2], which did not at all rely on any classification result in lower genus. On the other hand, the present work is built upon the results in $\mathcal{H}(4)$ by degenerating to $\mathcal{H}(4)$ and drawing conclusions from this degeneration; see Theorem 6.4 and Lemmas 6.8 and 6.15, for example.

Combinatorial strategy The general philosophy behind this work falls perfectly in line with that of [15; 2]. In both of those works, all of the cylinder diagrams were enumerated and studied in depth until the final result emerged. In each of those works, the combinatorics were manageable in the sense that there were very few cylinder diagrams, they could be enumerated by hand, and the desired conclusions could be derived with reasonable effort. On the other hand, a brute force approach to

¹This list is not exhaustive.

the classification problem in genus three by studying individual cylinder diagrams is hopeless. There are over nine pages of cylinder diagrams in genus three with two or more cylinders! While a general argument for the 2–cylinder diagrams is relatively easy, the situation is far more complicated for 3–cylinder diagrams.

After separating the cylinder diagrams by the number of cylinders, we make an additional separation of n –cylinder diagrams by the topology of the degenerate surfaces that are seen by pinching the core curves of every cylinder in the n –cylinder diagram; see Lemmas 4.1 and 6.1.

For 3–cylinder diagrams, we have three cases (see Lemma 4.1). Two of the cases are relatively easy to deal with in order to obtain surfaces with more horizontal cylinders. The most complicated case of 3–cylinder diagrams—see Case 3.I—is when the three core curves of the cylinders span a Lagrangian subspace of homology. Most of the 3–cylinder diagrams fall into this case. Of the numerous cylinder diagrams, we single out two properties that categorize all except one of the 3–cylinder diagrams in this case. Then we prove that, from these properties, we can always produce a 4–cylinder diagram, and this can also be accomplished in the exceptional case; see Section 5F.

Finally, we enumerate all of the 4–cylinder diagrams, of which there are not many, and prove the desired result. We remark that the combinatorics in this paper can be done entirely without the use of a computer program such as Sage. It suffices to study the dual graph of a periodic translation surface to enumerate all of the desired cylinder diagrams; see Section 2B and the appendix.

Acknowledgments This material is based upon work supported by the ERC Starting Grant “Quasiperiodic” of Artur Avila and later by the National Science Foundation under Award No. DMS - 1204414.

The authors warmly thank Alex Wright for his interest and for sharing with them numerous enlightening ideas and stimulating discussions, from which some of the lemmas in this paper were drawn. They are also grateful to him for his helpful comments on an earlier version of this paper. The authors are grateful to Mathematisches Forschungsinstitut Oberwolfach and the Université de Bordeaux, whose hospitality has enabled the collaboration that led to this work. Both authors thank Erwan Laneeau for helpful discussions and Vincent Delecroix for providing the list of cylinder diagrams, which inspired the strategy of the paper. They thank the referee for helpful advice that improved the exposition of this paper.

2 Preliminaries and general results

2A Preliminaries

Strata of translation surfaces A *translation surface* $M = (X, \omega)$ is a Riemann surface X of genus $g \geq 2$ carrying an abelian differential ω . The abelian differential imposes a flat geometry on the Riemann surface up to a finite number of points $\Sigma \subset X$ corresponding to zeros of ω . Let each zero in Σ have order k_i , so that $\kappa = (k_1, \dots, k_n)$ is a partition of $2g - 2$, the total order of the zeros of an abelian differential. Let $\mathcal{H}(\kappa)$ denote a *stratum of translation surfaces* of genus g translation surfaces carrying abelian differentials with zeros of orders specified by κ .

$GL^+(2, \mathbb{R})$ action There is an action by $GL^+(2, \mathbb{R})$ on strata of abelian differentials given by embedding a translation surface in the plane as a collection of polygons and acting on the plane by $GL^+(2, \mathbb{R})$.

Period coordinates Strata of translation surfaces admit a natural local coordinate system given as follows: Let $\{\gamma_i\} \subset H_1(X, \Sigma, \mathbb{Z})$ be a basis for relative homology. Consider the map

$$\Phi : (X, \omega) \mapsto \left(\int_{\gamma_1} \omega, \dots, \int_{\gamma_d} \omega \right).$$

This map is called the *period mapping*; it identifies a neighborhood of (X, ω) in its stratum with an open subset of $H^1(X, \Sigma, \mathbb{C})$. Consequently, Φ defines a coordinate system of $\mathcal{H}(\kappa)$; the coordinate changes of this system are given by matrices in $GL(d, \mathbb{Z})$, where $d = \dim H^1(X, \Sigma, \mathbb{C})$. In particular, $\mathcal{H}(\kappa)$ admits a complex affine structure.

Affine manifolds (see [5]) An *affine invariant submanifold* of $\mathcal{H}(\kappa)$ is an immersed submanifold \mathcal{M} that is invariant under the action by $GL^+(2, \mathbb{R})$ and admits a locally linear structure in period coordinates. Throughout this paper, we abbreviate it to *affine manifold*. By [5; 6], every $GL^+(2, \mathbb{R})$ -orbit closure is an affine manifold.² Moreover, if \mathcal{M} is an affine submanifold, and $\mathcal{M}_{(1)}$ is the subset of \mathcal{M} consisting of surfaces of area one, then $\mathcal{M}_{(1)}$ carries a finite ergodic measure for the action of $SL_2(\mathbb{R})$ which is induced by the Lebesgue measure on \mathcal{M} . Since the work of [5; 6], affine manifolds have been shown to have a lot of additional structure. It was shown in [8] that \mathcal{M} is a quasiprojective algebraic subvariety of $\mathcal{H}(\kappa)$.

²In fact, $GL^+(2, \mathbb{R})$ -orbit closures are not manifolds, but after passing to a finite cover, which we do throughout this paper, they become immersed submanifolds. In particular, they may have finitely many self-intersections. See [6, Definition 1.1] for details.

Let $T_M(\mathcal{M}) \subset H^1(X, \Sigma, \mathbb{C})$ denote the tangent space to \mathcal{M} at M . The tangent space behaves well under the tensor product with \mathbb{C} . Precisely speaking, there is a decomposition of the tangent space such that

$$T_M^{\mathbb{R}}(\mathcal{M}) \otimes \mathbb{C} \subset H^1(X, \Sigma, \mathbb{R}) \otimes \mathbb{C},$$

so that $T_M^{\mathbb{R}}(\mathcal{M}) \subset H^1(X, \Sigma, \mathbb{R})$.

Field of affine definition Let $k(\mathcal{M})$ be the smallest field in which the coefficients of the linear equations defining \mathcal{M} lie. It was proven in [17] that $k(\mathcal{M}) \subset \mathbb{R}$ is a number field of degree at most g over the rationals. We call an affine manifold \mathcal{M} *arithmetic* if $k(\mathcal{M}) = \mathbb{Q}$.

Rank of an affine manifold Let $p: H^1(X, \Sigma, \mathbb{R}) \rightarrow H^1(X, \mathbb{R})$ be the canonical projection from relative to absolute cohomology. It was proven in [3] that $p(T_M^{\mathbb{R}}(\mathcal{M}))$ is symplectic, so in particular it is even dimensional. In [18], the *cylinder rank*, or *rank* for short, of an affine manifold was defined to be

$$\text{rank}(\mathcal{M}) = \frac{1}{2} \dim_{\mathbb{R}} p(T_M^{\mathbb{R}}(\mathcal{M})).$$

Flat structure A trajectory beginning and ending at a cone point of M is called a *saddle connection*. A periodic (closed) trajectory on a translation surface M that does not pass through the cone points of M determines a cylinder C of parallel periodic trajectories on M . The *height* h of C is the length of the line segment orthogonal to the core curve of the cylinder. The *width* w is defined to be the circumference of C , and the *modulus* of C is the quantity h/w . By definition C has two boundary components, each of which consists of one or more saddle connections and freely homotopic to the core curves. We will say that C is a *simple cylinder* if each of its boundary component consists of a single saddle connection.

Another important geometric parameter of a cylinder is its *twist*, which is somewhat more delicate to define. Let C be a horizontal cylinder. To define the twist of C we pick a saddle connection a in the bottom boundary of C and a saddle connection b in the top boundary of C . Consider a saddle connection s in C joining the left endpoint of a and the left endpoint of b . Let $x + iy$ be the period of s . Note that we must have $y = h$. The twist of C is then defined to be $x \bmod w\mathbb{Z}$. Note that there is a unique saddle connection s_0 in C having the same endpoints as s such that the real part x_0 of the period of s_0 satisfies $x_0 \in [0, w)$. By a slight abuse of notations, we sometimes say that the twist of C is x_0 .

A translation surface is said to be *horizontally periodic* if every trajectory on M in a fixed horizontal direction is closed. It is a theorem of [16] that every affine

manifold contains a horizontally periodic translation surface. A *cylinder diagram* is a representation of a translation surface M expressing M as a union of cylinders with marked saddle connections on the boundaries to indicate identifications. Cylinder diagrams do not record the individual lengths of the cylinders or the saddle connections in their boundaries, so the equivalence is much weaker than it is for translation surfaces, ie two different translation surfaces can have the same cylinder diagram. An n -cylinder diagram is a cylinder diagram with n cylinders.

\mathcal{M} -parallelism and free cylinders Two cylinders C_1 and C_2 (resp. two saddle connections σ_1 and σ_2) are said to be \mathcal{M} -parallel if their core curves are parallel (resp. σ_1 and σ_2 are parallel) and they remain parallel under all local deformations in \mathcal{M} . This notion is introduced in [18]. The property of being \mathcal{M} -parallel is an equivalence relation, so it makes sense to discuss an equivalence class of \mathcal{M} -parallel cylinders (resp. saddle connections). The following two definitions can be found in [18].

Definition 2.1 A cylinder C on M is said to be *free* if it is \mathcal{M} -parallel to no other cylinders on M . Equivalently, C is free if its equivalence class is $\{C\}$.

Definition 2.2 Let

$$a_s = \begin{pmatrix} 1 & 0 \\ 0 & e^s \end{pmatrix} \quad \text{and} \quad u_t = \begin{pmatrix} 1 & t \\ 0 & 1 \end{pmatrix}.$$

Let \mathcal{C} be an equivalence class of \mathcal{M} -parallel cylinders. Define the *cylinder twist* $u_t^{\mathcal{C}}$ (resp. *cylinder stretch* $a_s^{\mathcal{C}}$) to be the action of u_t (resp. a_s) restricted to \mathcal{C} and leaving the complement of \mathcal{C} fixed.

Theorem 2.3 [18, Theorem 5.1] *Let \mathcal{M} be an affine manifold. If \mathcal{C} is an equivalence class of \mathcal{M} -parallel horizontal cylinders on $M \in \mathcal{M}$, then $a_s^{\mathcal{C}}(u_t^{\mathcal{C}}(M)) \in \mathcal{M}$ for all $s, t \in \mathbb{R}$.*

Twist and preserving space Let M be a horizontally periodic translation surface in an affine manifold \mathcal{M} . The *twist space* of \mathcal{M} at M , denoted $\text{Twist}(M, \mathcal{M})$, is the largest subspace of $T_M^{\mathbb{R}}\mathcal{M}$ whose elements evaluate to zero on all horizontal saddle connections of M . The *cylinder preserving space* $\text{Pres}(M, \mathcal{M})$ is the largest subspace of $T_M^{\mathbb{R}}\mathcal{M}$ whose elements evaluate to zero on all core curves of horizontal cylinders of M . Clearly, $\text{Twist}(M, \mathcal{M}) \subseteq \text{Pres}(M, \mathcal{M})$.

Lemma 2.4 [18, Lemma 8.6] *Let M be a horizontally periodic translation surface in an affine manifold \mathcal{M} . If $\text{Twist}(M, \mathcal{M}) \neq \text{Pres}(M, \mathcal{M})$, then there exists a horizontally periodic translation surface in \mathcal{M} in a small neighborhood of M with more horizontal cylinders than M .*

Though it is not explicitly stated in the way it is phrased below, the following theorem follows from the proof of [18, Theorem 1.10] as well as [18, Corollary 8.12].

Theorem 2.5 [18] *Given an affine manifold \mathcal{M} of rank k , there exists a horizontally periodic translation surface $M \in \mathcal{M}$ such that $\text{Twist}(M, \mathcal{M}) = \text{Pres}(M, \mathcal{M})$, in which case the cylinders on M are split into at least k equivalence classes of \mathcal{M} -parallel cylinders, and the horizontal core curves of the cylinders on M span a subspace of $T_M(\mathcal{M})^*$ of dimension k .*

No set of core curves of parallel cylinders on a translation surface $M \in \mathcal{M}$ may span a subspace of $T_M(\mathcal{M})^$ of dimension greater than k .*

Cylinder proportions Let \mathcal{C} be an equivalence class of \mathcal{M} -parallel cylinders on a translation surface $M \in \mathcal{M}$. Let X be a cylinder on M (whose core curve is not necessarily parallel to those of the cylinders in \mathcal{C}). Define the *cylinder proportion* of X in \mathcal{C} to be

$$P(X, \mathcal{C}) = \frac{\text{Area}(X \cap (\bigcup_{C \in \mathcal{C}} C))}{\text{Area}(X)}.$$

Proposition 2.6 [15] *Let X and Y be \mathcal{M} -parallel cylinders on a translation surface $M \in \mathcal{M}$. Let \mathcal{C} be an equivalence class of \mathcal{M} -parallel cylinders on M . Then $P(X, \mathcal{C}) = P(Y, \mathcal{C})$.*

2B Dual graphs

To each cylinder decomposition we can associate an undirected graph as follows: the set of vertices of the graph is in one-to-one correspondence with the set of cylinders, each edge of the graph corresponds to a horizontal saddle connection, and the vertices that are connected by an edge correspond to cylinders that contain the corresponding saddle connection in their boundary. In particular, if there is a saddle connection that is contained in both the top and bottom boundary of a cylinder, then there is a loop at the corresponding vertex in the dual graph.

We can now list some elementary properties of dual graphs:

- (1) Dual graphs are connected.
- (2) The number of edges of a dual graph depends only on the stratum, this is because the maximal number of saddle connections in a fixed direction is completely determined by the total angles at the singularities. For $\mathcal{H}(4)$ this number is five and for $\mathcal{H}(m, n)$, $m + n = 4$, this number is six.
- (3) The valency of each vertex is at least two.

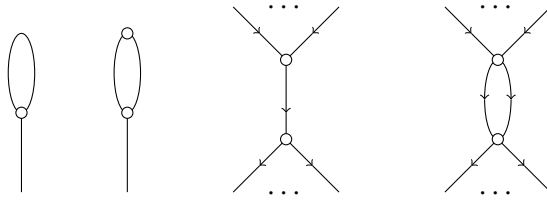

Figure 2: Forbidden configurations in a dual graph

- (4) In general, one cannot retrieve the cylinder diagram from the dual graph alone. To do this one needs to specify
- an orientation for each edge, the origin of which represents the cylinder that contains the corresponding saddle connection in the bottom border, while the head represents the cylinder that contains the corresponding saddle connection in the top border, and
 - a cyclic ordering on the set of outgoing (resp. incoming) rays at each vertex.

In what follows, we will call a dual graph with an orientation for each edge a *directed dual graph*, and a dual graph with orientation for each edge and cyclic orderings for the rays at each vertex a *complete dual graph*. It is worth noting that graphs with cyclic order of edges at every vertex are also called *fat graphs* or *ribbon graphs* in the literature (see eg [9, Section 2]).

- (5) One can put a positive weight on each edge of a directed dual graph such that the following condition is satisfied: at each vertex, the sum of the weights of the incoming rays equals the sum of weights of the outgoing rays.
- (6) The configurations in Figure 2 are forbidden in a dual graph.

The first two configurations (on the left) cannot occur in a dual graph since it is impossible to weight the (oriented) edges so that every vertex satisfies the condition that the sum of weights on the outgoing rays equals the sum of weights on the incoming rays. The last two configurations (on the right) correspond to two cylinders C_1 and C_2 such that the bottom side of C_1 equals the top side of C_2 . If the bottom side of C_1 consists of one or two saddle connections, then this would imply that C_1 and C_2 are actually included in a larger cylinder.

2C General results on arithmetic affine submanifolds

The following lemma is well known to experts and the interested reader can find a formal proof in [1].

Lemma 2.7 *Let \mathcal{M} be an affine manifold with rational affine field of definition. Then \mathcal{M} contains a dense set of square-tiled surfaces.*

Definition 2.8 A cylinder is called *simple* if each boundary consists of exactly one saddle connection.

Proposition 2.9 *Let \mathcal{M} be an affine manifold with rational affine field of definition. Let M be a surface in \mathcal{M} , $\{\sigma_i \mid i \in I\}$ be the set of horizontal saddle connections and $\{C_j \mid j \in J\}$ be the set of horizontal cylinders of M . Then there exists a square-tiled surface $M' \in \mathcal{M}$ close to M such that all of the saddle connections $\{\sigma_i \mid i \in I\}$ persist in M' and are also horizontal saddle connections in M' .*

It follows that $\{C_j \mid j \in J\}$ are also horizontal cylinders in M' . In particular, if C_j is a simple cylinder in M , it is also a simple cylinder in M' .

Proof For all $\varepsilon > 0$, consider the set $\tilde{U}_\varepsilon \subset \mathcal{H}(\kappa)$ of radius ε about M , where distance is measured in period coordinates. We can choose ε small enough so that all of the saddle connections $\{\sigma_i \mid i \in I\}$ persist on all surfaces $M' \in \tilde{U}_\varepsilon$. Set $U_\varepsilon := \tilde{U}_\varepsilon \cap \mathcal{M}$. We identify \tilde{U}_ε with an open subset of $H^1(M, \Sigma, \mathbb{R} + i\mathbb{R}) \simeq \mathbb{R}^{2d}$, and U_ε with an open subset of the linear subspace $T := T_M \mathcal{M}$. By assumption, T is defined by linear equations with rational coefficients.

Let $z_i = x_i + iy_i$ be the period of σ_i . Since σ_i is horizontal, we have $y_i = 0$ for all $i \in I$. Define the linear subspace

$$T' := \left(\bigcap_{i \in I} \{y_i = 0\} \right) \cap T \subset H^1(M, \Sigma, \mathbb{R} + i\mathbb{R}).$$

Consider the set $V_\varepsilon := \tilde{U}_\varepsilon \cap T'$. By definition, V_ε is an open subset of the linear subspace T' , which is defined only by (linear) equations with rational coefficients. It may happen that $T' = \{0\}$, but, by assumption, $M \in V_\varepsilon$, thus $\dim_{\mathbb{R}} T' > 0$, and $V_\varepsilon \neq \emptyset$. Therefore, one can find a point in V_ε with rational coordinates. This point represents a square-tiled surface M' for which $\{\sigma_i \mid i \in I\}$ are horizontal saddle connections.

Since the core curves of $\{C_j \mid j \in J\}$ are freely homotopic to a concatenation of some saddle connections in $\{\sigma_i \mid i \in I\}$, it follows that C_j persists in M' and is also horizontal for all $j \in J$. In particular, if C_j is a simple cylinder in M , then it is also a simple cylinder in M' . □

The following lemma is a special case of [2, Lemma 6.1]; we give the proof of this special case here for the convenience of the reader.

Lemma 2.10 *Let C_1 and C_2 be horizontal cylinders on a translation surface M . Assume that C_1 is a simple cylinder that is only adjacent to C_2 . If C_1 is free, then so is C_2 .*

Proof After appropriately twisting C_1 and the equivalence class of cylinders \mathcal{M} -parallel to C_2 , there is a vertical cylinder D intersecting only C_1 and C_2 such that $C_1 \subset \bar{D}$. We claim that D is free. Indeed, let D' be another cylinder \mathcal{M} -parallel to D . It follows from Proposition 2.6 that

$$P(D', \{C_1\}) = P(D, \{C_1\}) > 0,$$

which implies that $D' \cap C_1 \neq \emptyset$. But, by definition, C_1 is entirely contained in D , thus we have a contradiction, which means that D is alone in its equivalence class. Applying again Proposition 2.6 to the intersection of D with the equivalence class of C_2 , we see that any cylinder \mathcal{M} -parallel to C_2 must intersect D . But D intersects only two horizontal cylinders, namely C_1 and C_2 . Since C_1 is not \mathcal{M} -parallel to C_2 , we conclude that C_2 is also free. \square

Lemma 2.11 *Let \mathcal{M} be an affine manifold defined over \mathbb{Q} with rank at least two. Let $M \in \mathcal{M}$ admit a horizontal cylinder decomposition C_1, \dots, C_k . Assume that the core curves of C_1, \dots, C_k span a subspace of dimension at least two in $(T_M^{\mathbb{R}} \mathcal{M})^*$. If C_1 is a simple cylinder and C_1 is only adjacent to C_2 , then C_1 and C_2 cannot belong to the same equivalence class.*

Proof By contradiction, suppose that C_1 and C_2 are \mathcal{M} -parallel. After twisting C_2 by applying the horocycle flow to M , there is a pair of vertical saddle connections in C_2 that cut out a rectangle R whose horizontal sides form the boundary of C_1 . Since \mathcal{M} is defined over \mathbb{Q} , we can suppose that all of the periods of M are rational by Proposition 2.9. In particular, we can suppose that the ratio of the twist of C_1 and its circumference is rational. It follows that there exists a vertical cylinder D such that $\bar{D} = \bar{R} \cup \bar{C}_1$. We see that there is a single cylinder D that fills C_1 because $\bar{R} \cup \bar{C}_1$ can be regarded as a slit torus as in [2]; see Figure 3. Since the slit is vertical in this case, there is only one vertical cylinder if the vertical flow is periodic.

Let \mathcal{C} be the equivalence class of C_1 and \mathcal{D} the equivalence class of D . We have

$$P(C_1, D) = 1 \quad \implies \quad P(C_i, D) = 1 \quad \text{for all } C_i \in \mathcal{C},$$

which means that C_i is filled by vertical cylinders \mathcal{M} -parallel to D . On the other hand, we also have $P(D, \mathcal{C}) = 1$ since $D \subset \bar{C}_1 \cup \bar{C}_2$. Therefore, any vertical cylinder in \mathcal{D} intersects only cylinders in \mathcal{C} . It follows that a cylinder in \mathcal{C} can only be adjacent to cylinders in \mathcal{C} . By assumption, we know that there are at least two equivalence classes

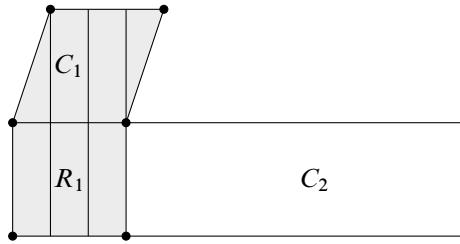

Figure 3: The shaded region realizes a slit torus containing C_1 . When the ratio of the twist and the circumference of C_1 is rational, the vertical flow in this slit torus is periodic. We then have a single vertical cylinder D that fills out this region.

of horizontal cylinders. Since the surface is connected, there must be a cylinder in \mathcal{C} which is adjacent to a cylinder in another equivalence class, and we get a contradiction. \square

Lemma 2.12 *Let \mathcal{M} be an affine manifold with rank at least two. Assume that $M \in \mathcal{M}$ admits a cylinder decomposition in the horizontal direction such that there are at least two equivalence classes of \mathcal{M} -parallel cylinders. Let C and C' be two horizontal cylinders in M . Suppose that the top boundary of C is contained in the bottom of cylinders that are not \mathcal{M} -parallel to C and there is a saddle connection which is contained in both the top and bottom borders of C' . Then C and C' cannot belong to the same equivalence class.*

Proof Assume by contradiction that C and C' are \mathcal{M} -parallel. Let us denote the equivalence class of C by \mathcal{C} . By assumption, there is a transverse cylinder D' contained in C' (we can suppose that D' is vertical). Since C is \mathcal{M} -parallel to C' , there must be a vertical cylinder D in the equivalence class of D' that crosses C . But, by assumption, any vertical cylinder crossing C must cross cylinders not in \mathcal{C} . Thus we have $P(D, \mathcal{C}) < 1$, while $P(D', \mathcal{C}) = 1$, which is a contradiction. \square

Remark 2.13 Lemma 2.12 already appeared in [2, Lemma 6.3].

Lemma 2.14 *Let \mathcal{M} be an affine manifold defined over \mathbb{Q} with rank at least two and M a translation surface in \mathcal{M} . Let $\mathcal{S} := \{C_i \mid i = 1, \dots, s\}$ denote the set of simple horizontal cylinders of M . Then there exists a surface $M' \in \mathcal{M}$, which is also decomposed into cylinders in the horizontal direction with at least s simple cylinders and at least two equivalence classes.*

Proof We follow the argument of [18, Lemma 8.6] combined with the hypothesis that \mathcal{M} is defined over \mathbb{Q} . Let $\text{Pres}(M, \mathcal{M}) \subset T_M^{\mathbb{R}}\mathcal{M}$ and $\text{Twist}(M, \mathcal{M}) \subset T_M^{\mathbb{R}}\mathcal{M}$ be as defined above. Using Proposition 2.9, we can assume that M is square-tiled.

Obviously we only have to consider the case where all of the horizontal cylinders of M belong to the same equivalence class, which means that the core curves c_1, \dots, c_k of these cylinders span a subspace of dimension one in $(T_M^{\mathbb{R}}\mathcal{M})^*$. By definition we have

$$\text{Pres}(M, \mathcal{M}) = \ker(c_1) \cap \dots \cap \ker(c_k) = \ker(c_1) \subset T_M^{\mathbb{R}}\mathcal{M}.$$

Therefore, $\text{Pres}(M, \mathcal{M})$ has codimension one. We know that $p(\text{Twist}(M, \mathcal{M}))$ is an isotropic subspace of $p(T_M^{\mathbb{R}}\mathcal{M})$ by [18, Lemma 8.10], thus $p(\text{Twist}(M, \mathcal{M}))$ has codimension at least two in $p(T_M^{\mathbb{R}}\mathcal{M})$, which implies that $\text{Twist}(M, \mathcal{M})$ has codimension at least two in $T_M^{\mathbb{R}}\mathcal{M}$. It follows that $\text{Twist}(M, \mathcal{M}) \subsetneq \text{Pres}(M, \mathcal{M})$.

Let $\eta \in \text{Pres}(M, \mathcal{M}) \setminus \text{Twist}(M, \mathcal{M})$ with all of its coordinates in \mathbb{Q} and small Euclidean norm. If $\|\eta\|$ is small enough, then $M' = M + \iota\eta$ is a well-defined surface in \mathcal{M} and all of the horizontal simple cylinders in M remain simple in M' . Observe that all of the coordinates of M' are rational. Thus, M' is a square tiled surface admitting a cylinder decomposition in the horizontal direction with more cylinders than M .

If there are two equivalence classes of horizontal cylinders on M' , we are done. Otherwise we can repeat the deformations along vectors in $\text{Pres}(M', \mathcal{M}) \setminus \text{Twist}(M', \mathcal{M})$ to get more horizontal cylinders. However, a cylinder decomposition of any surface in genus g cannot have more than $3g - 3$ cylinders. Therefore, after finitely many steps we get a horizontally periodic surface in \mathcal{M} with the maximal number of horizontal cylinders and at least s simple cylinders. If there is only one equivalence class, then the argument above shows that this procedure can be repeated to produce a surface with more horizontal cylinders, which is impossible. Therefore, we can conclude that there are at least two equivalence classes of horizontal cylinders. \square

Lemma 2.15 *Let \mathcal{M} be a rank two affine manifold in genus three. Suppose that $M \in \mathcal{M}$ is decomposed into three horizontal cylinders C_1, C_2, C_3 , with core curves c_1, c_2, c_3 , respectively. If $\{c_1, c_2, c_3\}$ span a Lagrangian subspace of $H_1(M, \mathbb{Z})$, then C_1, C_2, C_3 cannot all be free.*

Proof This lemma is a consequence of Theorem 2.3 and the fact that the projection of $T_M^{\mathbb{R}}\mathcal{M}$ in $H^1(M, \mathbb{R})$ is symplectic. The shearing of C_i corresponds to a vector $\xi_i \in T_M^{\mathbb{R}}\mathcal{M} \subset H^1(M, \Sigma, \mathbb{Z})$ which maps to c_i via the identification of $H^1(X, \Sigma, \mathbb{Z})$ with $H_1(M \setminus \Sigma, \mathbb{Z})$ (see [18, Lemma 2.4, Remark 2.5]). Since the projection from $H^1(M, \Sigma, \mathbb{Z})$ to $H^1(M, \mathbb{Z})$ can be also identified with the projection

from $H_1(M \setminus \Sigma, \mathbb{Z})$ to $H_1(M, \mathbb{Z})$, the images of ξ_1, ξ_2, ξ_3 in $H^1(M, \mathbb{Z})$ span a 3-dimensional isotropic space. But this is impossible since $p(T_M^{\mathbb{R}}\mathcal{M})$ is a symplectic subspace of dimension four in $H^1(M, \mathbb{R})$. \square

2D Cylinder collapsing

Let \mathcal{H}_g denote the vector bundle of abelian differentials over the moduli space \mathcal{M}_g . Let \mathcal{M} be an affine submanifold of $\mathcal{H}(\kappa) \subset \mathcal{H}_g$. Let M be a surface in \mathcal{M} and $\mathcal{C} = \{C_0, C_1, \dots, C_k\}$ be an equivalence class of \mathcal{M} -parallel horizontal cylinders on M . We do not assume here that M is horizontally periodic. The deformations $\{a_t^{\mathcal{C}}(M), t \in \mathbb{R}\}$ of M by stretching simultaneously the cylinders in \mathcal{C} define a path in $\mathcal{H}(\kappa)$. If $a_t^{\mathcal{C}}(M)$ admits a limit M' in \mathcal{H}_g as $t \rightarrow -\infty$, then we will say that M' is obtained from M by *collapsing the equivalence class \mathcal{C}* . In Figure 4, we represent some limits of cylinder collapsing deformations in $\mathcal{H}_2 = \mathcal{H}(2) \sqcup \mathcal{H}(1, 1)$.

The following proposition is an important tool for our proof of the main theorem:

Proposition 2.16 *Assume that:*

- (a) *The family \mathcal{C} does not fill M .*
- (b) *If C and C' are two horizontal cylinders (C and C' may be the same) such that there is a saddle connection that is contained in the bottom boundary of C and in the top boundary of C' , then either $C \notin \mathcal{C}$ or $C' \notin \mathcal{C}$.*

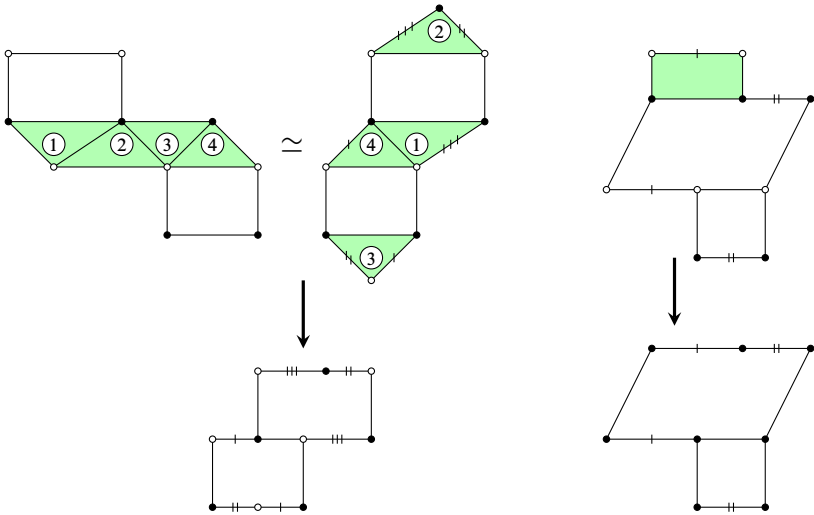

Figure 4: Collapsing \mathcal{M} -parallel cylinders of a surface in $\mathcal{H}(1, 1)$; the collapsed cylinder is shaded. On the left, the limit remains in $\mathcal{H}(1, 1)$; on the right, the limit belongs to $\mathcal{H}(2)$.

- (c) There exists a vertical saddle connection σ in C_0 joining two distinct singularities, and any other saddle connection contained in one of the cylinders C_i , $i = 0, \dots, k$, has nonzero real part.

Then $a_t^C(M)$ converges as $t \rightarrow -\infty$ to a surface M' which belongs to another stratum $\mathcal{H}(\kappa') \subset \mathcal{H}_g$ with $|\kappa'| = |\kappa| - 1$. Moreover, M' is contained in an affine invariant submanifold \mathcal{M}' of $\mathcal{H}(\kappa')$ which has the same rank as \mathcal{M} .

- Remarks 2.17**
- There is an implicit assumption in Proposition 2.16, namely M has at least two singularities, or equivalently $|\kappa| \geq 2$.
 - The condition (b) on \mathcal{C} implies in particular that no cylinder in the family \mathcal{C} has a saddle connection contained in both of its top and bottom boundary.

Proof We first show that $a_t^C(M)$ admits a limit in $\mathcal{H}(\kappa')$ with $|\kappa'| = |\kappa| - 1$ as $t \rightarrow -\infty$. Let $\sigma' \neq \sigma$ be a saddle connection of M . There exists $\varepsilon_1 > 0$ such that the length of any subsegment of σ' outside of the union $\bigcup_{i=0}^k C_i$ is at least ε_1 . Condition (b) implies that if σ' is contained in $\bigcup_{i=0}^k C_i$, then σ' is actually contained in one of the cylinders C_0, \dots, C_k because Condition (b) excludes the existence of adjacent cylinders in \mathcal{C} . By condition (c), there exists $\varepsilon_2 > 0$ such that, if σ' is contained in one of the cylinders C_0, \dots, C_k and $\sigma' \neq \sigma$, then the real part $\text{Re}(\sigma')$ of σ' satisfies $|\text{Re}(\sigma')| > \varepsilon_2$. From these observations, we see that if $t < 0$ and $|t|$ is large enough then any saddle connection $\sigma' \neq \sigma$ has length bounded away from zero in $a_t^C(M)$, where the bound depends on M and not t .

We can now apply the *collapsing a pair of zeros* procedure described in [4, Section 8.2] to σ to get a surface $M'_t \in \mathcal{H}(\kappa')$ with $|\kappa'| = |\kappa| - 1$. It is not difficult to check that M'_t converges as $t \rightarrow -\infty$ to a surface $M' \in \mathcal{H}(\kappa')$. It is a well-known fact that the intersection of a neighborhood of M' in \mathcal{H}_g with $\mathcal{H}(\kappa)$ consists of surfaces obtained by a *breaking up a zero* construction applied to surfaces in a neighborhood of M' in $\mathcal{H}(\kappa')$ (see [10, Section 5]). Therefore, given any neighborhood \mathcal{U} of M' , we have $a_t^C(M) \in \mathcal{U}$ for $t < 0$ and $|t|$ large enough. We can then conclude that M' is the limit in \mathcal{H}_g of the path $a_t^C(M)$ as $t \rightarrow -\infty$.

Let $\overline{\mathcal{M}}$ be the closure of \mathcal{M} in \mathcal{H}_g . Let \mathcal{M}' be the intersection $\overline{\mathcal{M}} \cap \mathcal{H}(\kappa')$. By [8], we know that \mathcal{M} is an algebraic subvariety of \mathcal{H}_g , therefore $\overline{\mathcal{M}} \setminus \mathcal{M}$ has dimension strictly smaller than \mathcal{M} . In particular, we have $\dim_{\mathbb{C}} \mathcal{M}' < \dim_{\mathbb{C}} \mathcal{M}$. Note that \mathcal{M}' may have several components since there may be more than one way to degenerate surfaces in $\mathcal{H}(\kappa)$ to surfaces in $\mathcal{H}(\kappa')$.

By definition, \mathcal{M}' is a closed $\text{GL}^+(2, \mathbb{R})$ -invariant subset of $\mathcal{H}(\kappa')$. Thus each component of \mathcal{M}' must be an affine submanifold of $\mathcal{H}(\kappa')$, and therefore is locally

defined by linear equations with real coefficients. We can consider the tangent space of \mathcal{M}' at M' , denoted by $T_{M'}\mathcal{M}'$, as the union of the tangent spaces of its irreducible components at M' . In particular, we have

$$T_{M'}\mathcal{M}' = T_{M'}^{\mathbb{R}}\mathcal{M}' \otimes \mathbb{C},$$

where $T_{M'}^{\mathbb{R}}\mathcal{M}'$ is the union of finitely many linear subspaces of $H^1(M', \Sigma', \mathbb{R})$ with Σ' being the set of singularities of M' . We will show that there exists an irreducible component \mathcal{M}'_0 of \mathcal{M}' , containing M' , such that $\dim_{\mathbb{C}} \mathcal{M}'_0 = \dim_{\mathbb{C}} \mathcal{M} - 1$ and $\text{rank } \mathcal{M}'_0 = \text{rank } \mathcal{M}$.

Pick a basis \mathcal{B} of $H_1(M, \Sigma, \mathbb{Z})$ where σ is an element of \mathcal{B} , and any other element of \mathcal{B} is either a saddle connection in the complement of $\bigcup_{i=0}^k C_i$, or a saddle connection in the closure of one of the cylinders C_i , $i = 0, \dots, k$. A saddle connection in the latter case either crosses each core curve of C_i once or is contained in the boundary of C_i . Using \mathcal{B} , we can identify $H^1(M, \Sigma; \mathbb{R})$ with $(\mathbb{R})^{\mathcal{B}}$. Set $V := T_M^{\mathbb{R}}\mathcal{M} \subset H^1(M, \Sigma; \mathbb{R})$, and denote by $p: H^1(M, \Sigma; \mathbb{R}) \rightarrow H^1(M, \mathbb{R})$ the canonical projection. Recall that we have $\dim_{\mathbb{R}} p(V) = 2l$, where l is the rank of \mathcal{M} .

From [Theorem 2.3](#), we can freely stretch and shear \mathcal{C} while keeping the rest of the surface unchanged, the new surfaces always belong to \mathcal{M} . Let $\xi := (\xi(s))_{s \in \mathcal{B}}$ be the tangent vector to the path in \mathcal{M} corresponding to the shearing operation of \mathcal{C} . We have $\xi(\sigma) = 1$, and $\xi(s) = 0$ for any s which does not cross any cylinder in the family \mathcal{C} .

Using the period mapping, we can identify a neighborhood of M with an open subset $U \subset V \otimes_{\mathbb{R}} \mathbb{C}$. Let X be the image of M by this identification. Recall that $\text{Re}(X(\sigma)) = 0$ and, for any other saddle connection s contained in \bar{C}_i , we must have $|\text{Re}(X(s))| > \varepsilon_2$.

Set $V' := \{v \in V \mid v(\sigma) = 0\} \subset V$. Since V' is a subspace of V which is defined by a unique linear equation, V' has codimension at most one. Observe that $\xi \notin V'$ since $\xi(\sigma) = 1$, from which we derive that V' is a proper linear subspace of codimension one in V . For any fixed $v \in V'$, and $\varepsilon > 0$ small enough, the vector $X_{\varepsilon v} := X + \varepsilon v$ belongs to U , hence corresponds to a surface in \mathcal{M} close to M . Since $v \in H^1(M, \Sigma; \mathbb{R})$, the cylinders in the family \mathcal{C} persist in the surface $X_{\varepsilon v}$. Moreover, if ε is small enough, then for any saddle connection $s \neq \sigma$ which is contained in one of the cylinders C_i , we have $\text{Re}(X_{\varepsilon v}(s)) \neq 0$. It follows that the cylinder collapsing operation applied to the surface represented by $X_{\varepsilon v}$ also yields a surface in $\mathcal{H}(\kappa')$.

Set $\mathcal{B}' := \mathcal{B} \setminus \{\sigma\}$. Recall that by the choice of \mathcal{B} , any element of \mathcal{B} is either a saddle connection contained in the closure of one of the cylinders C_1, \dots, C_k , or disjoint from those cylinders. Let s be a saddle connection in \mathcal{B}' . If s is disjoint from $\bigcup_{i=0}^k \bar{C}_i$, then clearly s persists in M' . If s is contained in the closure of a cylinder C_i , then

s degenerates as $t \rightarrow -\infty$ to the union of one or more horizontal saddle connections in M' . Nevertheless, we claim that \mathcal{B}' still represents a basis of $H_1(M', \Sigma'; \mathbb{Z})$, where Σ' is the set of singularities of M' . To see this we first notice that the pairs $(M, \Sigma \cup \sigma)$ and (M', σ') are homotopy equivalent, thus $H_1(M', \Sigma'; \mathbb{Z})$ can be identified with $H_1(M, \Sigma \cup \sigma; \mathbb{Z})$. The natural projection $\rho: H_1(M, \Sigma; \mathbb{Z}) \rightarrow H_1(M, \Sigma \cup \sigma; \mathbb{Z})$ is surjective. Since $\rho(\sigma) = 0 \in H_1(M, \Sigma \cup \sigma; \mathbb{Z})$, \mathcal{B}' must be mapped to a basis of $H_1(M, \Sigma \cup \sigma; \mathbb{Z})$.

Since a vector in V' is uniquely determined by its evaluations on \mathcal{B}' , the collapsing of the cylinders in \mathcal{C} provides us with an embedding of V' into $T_{M'}^{\mathbb{R}} \mathcal{M}' \subset H^1(M', \Sigma'; \mathbb{R})$. Since $T_{M'}^{\mathbb{R}} \mathcal{M}'$ is the union of finitely many subspaces of $H^1(M', \Sigma', \mathbb{R})$, there must exist an irreducible component \mathcal{M}'_0 of \mathcal{M}' containing M' such that $T_{M'}^{\mathbb{R}} \mathcal{M}'_0$ contains V' . In particular, we must have $\dim_{\mathbb{R}} T_{M'}^{\mathbb{R}} \mathcal{M}'_0 \geq \dim_{\mathbb{R}} V' = \dim_{\mathbb{R}} V - 1$. It follows that $\dim_{\mathbb{C}} \mathcal{M}'_0 \geq \dim_{\mathbb{C}} \mathcal{M} - 1$. Since $\dim_{\mathbb{C}} \mathcal{M}'_0 \leq \dim_{\mathbb{C}} \mathcal{M} - 1$, we can conclude that $\dim_{\mathbb{C}} \mathcal{M}'_0 = \dim_{\mathbb{C}} \mathcal{M} - 1$ and V' is isomorphic to $T_{M'}^{\mathbb{R}} \mathcal{M}'_0$.

It remains to show that $\dim p(V') = \dim p(V)$. Note that in this case we can identify $H^1(M', \mathbb{R})$ with $H^1(M, \mathbb{R})$, and $p(V')$ with $p(T_{M'}^{\mathbb{R}} \mathcal{M}'_0)$. Assume that $\dim p(V') < \dim p(V)$. Since \mathcal{M}'_0 is an affine submanifold of $\mathcal{H}(\kappa')$, $p(V')$ is a symplectic subspace of $H^1(M, \mathbb{R})$ by [3], therefore $\dim p(V') \leq \dim p(V) - 2$. But we have $\dim V' = \dim V - 1$, therefore $\dim p(V') \geq \dim p(V) - 1$, and we get a contradiction. Thus, $\dim p(V') = \dim p(V)$, which means that \mathcal{M}'_0 and \mathcal{M} have the same rank. The proof of the proposition is now complete. □

Remark 2.18 On first glance, Proposition 2.16 may seem troubling because, if there are two equivalence classes, we may only see one equivalence class of cylinders in the limit, which gives the impression of degenerating from rank two to rank one. Indeed such degenerations will arise in Lemma 6.10. However, this apparent contradiction is only an illusion, because the surface can be deformed prelimit before collapsing cylinders to produce a family of translation surfaces that cannot lie in a rank one orbit closure. In the aforementioned lemma, this is especially clear because all rank one orbit closures in $\mathcal{H}(4)$ are Teichmüller curves, so any deformation that is not by $SL_2(\mathbb{R})$ implies that the degenerate surfaces must lie in an affine submanifold of higher rank.

Furthermore, Proposition 2.16 does not claim that in the presence of several zeros, it is always possible to collapse cylinders to get a rank k manifold in the same genus. For example, consider the Prym locus in $\mathcal{H}(2, 2)^{\text{hyp}}$. It is 4-dimensional and has rank two. Indeed, the intersection of the boundary of the affine manifold with all lower strata in the same genus is the empty set.

Remark 2.19 A more detailed account and general results on the closure of \mathcal{M} in a partial compactification of \mathcal{H}_g are given in a new preprint by Mirzakhani and Wright [13].

3 Two cylinders

The following lemmas are valid in any stratum $\mathcal{H}(\kappa)$ of any genus $g \geq 3$.

Lemma 3.1 *If M is a union of two nonhomologous cylinders, then at least one of them has a saddle connection on its top and bottom.*

Proof If not, then they would be homologous. □

Lemma 3.2 *Let \mathcal{M} be a rank two affine submanifold of $\mathcal{H}(\kappa)$, where $g \geq 3$, with rational affine field of definition. Then \mathcal{M} contains a horizontally periodic translation surface with at least three cylinders.*

Proof By [Theorem 2.5](#), we know that \mathcal{M} contains a surface M which is horizontally periodic with at least two cylinders. Obviously we only need to consider the case where M has exactly two cylinders C_1 and C_2 . Note that in this case the two cylinders are not \mathcal{M} -parallel, by [Theorem 2.5](#). By [Lemma 3.1](#), without loss of generality, assume that C_1 contains a simple cylinder C'_1 formed by considering the foliation in the direction that connects the saddle connection on the top of C_1 with its copy on the bottom of C_1 . Using $\text{SL}(2, \mathbb{R})$, we can assume that C'_1 is vertical.

Since the affine field of definition of \mathcal{M} is \mathbb{Q} , by [Proposition 2.9](#) there exists a square-tiled surface M' close to M , on which C'_1 is also a vertical simple cylinder. Note that M' is vertically periodic, and has at least two vertical cylinders. If M' has more than two vertical cylinders, then we are done. Thus, we only need to consider the case where M' has only one vertical cylinder other than C'_1 . Rotate M' by $\frac{\pi}{2}$, so that C'_1 is now a horizontal simple cylinder. Let C'_2 be the other horizontal cylinder of $R_{\pi/2} \cdot M'$, where $R_\theta = \begin{pmatrix} \cos \theta & -\sin \theta \\ \sin \theta & \cos \theta \end{pmatrix}$. If C'_1 and C'_2 are \mathcal{M} -parallel, then by [Theorem 2.5](#), there exists a horizontally periodic surface in a neighborhood of $R_{\pi/2} \cdot M'$ with at least three cylinders and we are done. Therefore, we only need to consider the case where C'_1 and C'_2 are free.

Recall that C'_1 is simple, thus there exists a pair of homologous saddle connections σ_1, σ_2 in C'_2 that cut out a slit torus T' containing C'_1 . Since C'_1 and C'_2 are free, we can freely twist C'_1 and C'_2 so that σ_i is vertical, and the twist of C'_1 is zero, that is C'_1 can be represented by a rectangle. It follows that \mathcal{M} contains a surface which has a

vertical cylinder C_1'' whose closure is a slit torus. By a slight abuse of notation, we still denote this surface by M' . Let σ_0 denote the unique vertical saddle connection in C_1' ; then the two boundaries of C_1'' are $\sigma_0 \cup \sigma_1$ and $\sigma_0 \cup \sigma_2$.

Since \mathcal{M} is defined over \mathbb{Q} , there exists a square-tiled surface M'' close to M' on which $\sigma_0, \sigma_1, \sigma_2$ persist and are also vertical ([Proposition 2.9](#)). In particular, C_1'' persists on M'' . Since the vertical direction on M'' is periodic, M'' has vertical cylinders other than C_1'' . Again we only have to consider the case where M'' has two vertical cylinders C_1'' and C_2'' , both are free otherwise we can conclude by [Theorem 2.5](#). Rotate M'' by $\frac{\pi}{2}$, so that C_1'' and C_2'' are horizontal. Note that one of σ_1 or σ_2 is contained in the top boundary of C_2'' and the other one is contained in the bottom boundary of C_2'' . Let η_1, η_2 be a pair of saddle connections in C_2'' that cut out a parallelogram whose top and bottom sides are σ_1 and σ_2 . We can freely twist C_1'' and C_2'' so that there exist two vertical cylinders: D_1 is a cylinder in C_1'' that contains σ_0 and D_2 is the vertical cylinder through σ_1 and σ_2 which is bounded by η_1, η_2 and the saddle connections in the boundary of D_1 . Since $g \geq 3$, $D_1 \cup D_2$ cannot fill the whole surface, therefore there exists in \mathcal{M} a vertically periodic surface with at least three cylinders. The lemma is then proved. \square

We also need the following lemma, which is specific to the cases $\mathcal{H}(m, n)$ with $m+n=4$ and strengthens [Lemma 3.2](#) a little in those cases.

Lemma 3.3 *Let \mathcal{M} be a rank two submanifold of $\mathcal{H}(m, n)$ with $m+n=4$. Assume that \mathcal{M} contains a surface M which is horizontally periodic with two cylinders, one of which is simple. Then \mathcal{M} contains a horizontally periodic surface with at least three cylinders, one of which is simple and not free.*

Proof Let C_1 and C_2 be the horizontal cylinders of M , where C_1 is simple. If C_1 and C_2 are \mathcal{M} -parallel then $\text{Twist}(M, \mathcal{M}) \neq \text{Pres}(M, \mathcal{M})$, thus we can use the arguments in [Lemma 2.14](#) to get a square-tiled surface M' close to M on which C_1 and C_2 persist (they are always \mathcal{M} -parallel). The cylinder C_1 is still a simple cylinder, but M' has at least three horizontal cylinders, hence the lemma is proved for this case.

Assume now that C_1 and C_2 are both free. Since C_1 is simple, the top (resp. bottom) border of C_1 contains only one singularity of M . Note that the bottom border (resp. top border) of C_1 is properly contained in the top border (resp. bottom border) of C_2 , and any horizontal saddle connection which is not a border of C_1 is contained in both top and bottom borders of C_2 . From these observations, we derive that if the top border of C_2 contains only one singularity then its bottom border only contains the same singularity, which means that M has only one singularity.

Since we have assumed that $M \in \mathcal{H}(m, n)$, there must exist a saddle connection σ connecting two distinct zeros which is contained in both top and bottom borders of C_2 . Let C' be the simple cylinder in C_2 consisting of trajectories crossing σ and no other horizontal saddle connections. We can assume C' is vertical.

Again, since \mathcal{M} is defined over \mathbb{Q} , we can find in a neighborhood of M a square-tiled surface M' on which C' is still a simple vertical cylinder. Note that the surface M' is vertically periodic. We claim that C' is not free. Indeed, if C' is free, then we can collapse it so that the two zeros in its borders collide, and the resulting surface, denoted by M'' , belongs to $\mathcal{H}(4)$. From [Proposition 2.16](#), we know that M'' must belong to a rank two affine submanifold \mathcal{M}' of $\mathcal{H}(4)$.

From [Theorem 1.4](#), we have $\mathcal{M}' = \tilde{\mathcal{Q}}(3, -1^3)$, therefore $M'' \in \tilde{\mathcal{Q}}(3, -1^3)$. Observe that by construction M'' admits a cylinder decomposition in the horizontal direction into two cylinders, one of which is simple. But it is impossible for surfaces in $\tilde{\mathcal{Q}}(3, -1^3)$ to have such a cylinder decomposition. This is because there is an involution τ with four fixed points in M'' , and in particular τ must permute the two cylinders in this decomposition. Thus we have a contradiction, which implies that C' is not free.

Let \mathcal{C}' be the equivalence class of C' in M' , then \mathcal{C}' contains at least two cylinders. Since $P(\mathcal{C}', \{C_2\}) = 1$, for any $C'' \in \mathcal{C}'$ we also have $P(C'', \{C_2\})$, which means that C'' is contained in the closure of C_2 . It follows that the cylinders in \mathcal{C}' do not fill M' . Therefore, M' has at least three cylinders in the vertical direction. The proof of the lemma is now complete. \square

4 Three cylinders

Convention Throughout this section, we will use the following convention for specifying cases: Case $n.R.\square$ will denote a horizontally periodic translation surface with n cylinders such that pinching the core curves of every cylinder results in a degenerate surface on a list specified below and denoted by a Roman numeral R . The final term will often be omitted, and is used only if there is a need to specify a subcase.

We would like to stress the fact that even though our main results only concern strata with two zeros in genus three, some of the following lemmas are actually valid for all strata in genus three. We begin by considering all possible topological configurations for a degenerate surface resulting from pinching the core curves of every cylinder in a 3-cylinder diagram in genus three. We adopt the usual terminology and call a connected component of a degenerate Riemann surface (after removing nodes) a *part*. We also pinch the core curves of cylinders by letting their heights go to infinity,

while their circumferences remain fixed. With respect to the abelian differential on the surface, this implies that each infinite cylinder gives rise to a pair of simple poles. Whenever we use the terminology *pair of poles* we will specifically be referring to the two poles arising from pinching a single core curve of a cylinder.

Lemma 4.1 *If a horizontally periodic genus three translation surface M decomposes into exactly three cylinders, then pinching the core curves of those cylinders, by letting the heights of the cylinders go to infinity so that each cylinder becomes a pair of simple poles of an abelian differential, degenerates the surface to one of three possible surfaces:*

- (3.I) *a sphere with three pairs of simple poles,*
- (3.II) *a sphere and a torus joined by three pairs of simple poles, or*
- (3.III) *a sphere with a pair of simple poles joined to a torus by two pairs of simple poles.*

Proof If the surface decomposes into two parts, then there must be at least two nodes joining the two parts because the core curve of the cylinder of an abelian differential can never be a separating curve. If there are exactly two nodes (pairs of poles) between the two parts, then the third pair of poles must lie on one of the parts. This accounts for all pairs of poles and Case 3.III is the only possibility.

Finally, if there are three pairs of simple poles between the two parts, again the parts are completely determined because all cylinders are accounted for and we get Case 3.II. Since each part must carry at least two simple poles and a sphere must have at least three simple poles on it, it is not possible to have three or more parts with three cylinders in genus three. \square

Remark 4.2 We observe that there is an obvious homological relation among the core curves of cylinders when the surface degenerates to each of Cases 3.II and 3.III. Namely, the homology class of one cylinder is equal to the sum of the other two (Case 3.II), and the core curves of two cylinders are equal in homology (Case 3.III). However, in Case 3.I, the core curves of the three cylinders span a Lagrangian subspace of homology because degenerating to a sphere indicates that there is no homological relation among the cylinders.

4A Case 3.II

The goal of this section is to eliminate Case 3.II by proving that if there is a surface satisfying Case 3.II in a rank two affine manifold \mathcal{M} in a stratum with two zeros in genus three, then there is a translation surface in \mathcal{M} with four horizontal cylinders.

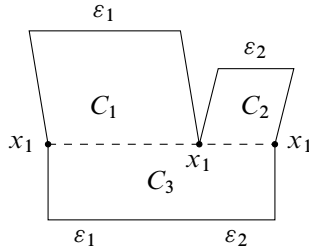

Figure 5: In Case 3.II, a surface in genus three with a simple zero x_1 , and ε_i denotes a collection of saddle connections

Lemma 4.3 *Let \mathcal{M} be a rank two affine manifold in a stratum in genus three with $k \geq 2$ zeros. If every translation surface in every rank two manifold \mathcal{M}' in every stratum in genus three with at most $k - 1$ zeros admits a double covering to a half-translation surface, then there does not exist a horizontally periodic translation surface $M \in \mathcal{M}$ satisfying Case 3.II such that $\text{Twist}(M, \mathcal{M}) = \text{Pres}(M, \mathcal{M})$.*

Proof By contradiction, assume $M \in \mathcal{M}$ satisfies Case 3.II and $\text{Twist}(M, \mathcal{M}) = \text{Pres}(M, \mathcal{M})$. By Theorem 2.5, there are at least two equivalence classes of cylinders. In fact, all three cylinders must be free because of the homological relation $c_1 + c_2 = c_3$, where c_i is a core curve of the cylinder C_i . Any relation between two of the cylinders induces a relation with the third. Note that the zero x_1 in Figure 5 on the bottom of C_2 cannot occur on the top of C_2 because x_1 is a simple zero. Therefore, we can twist and collapse C_2 while fixing the rest of the surface to reach a translation surface in a lower stratum in genus three. The resulting surface M' must be contained in a rank two affine manifold by Proposition 2.16, or the fact that C_1 and C_3 are free.

Finally, we claim that M' cannot be a double covering of a half translation surface. First of all, C_1 and C_3 have unequal circumferences, so any double covering would induce an involution sending C_i into itself for $i = 1, 3$. In the argument above, at least one of the cylinders C_1 or C_2 is not simple and so we could label C_1 to be the cylinder that is not simple. If neither is simple, then choose one of them. However, if C_1 is not simple, then an involution of order two would send all of the saddle connections on its top into the single saddle connection on its bottom. This is impossible and contradicts the assumption that the rank two manifold in the boundary of \mathcal{M} admits a double cover to a stratum of half-translation surfaces. \square

Corollary 4.4 *If \mathcal{M} is a rank two submanifold in $\mathcal{H}(m, n)$ with $m + n = 4$, then \mathcal{M} does not contain any horizontally periodic surface M satisfying Case 3.II such that $\text{Twist}(M, \mathcal{M}) = \text{Pres}(M, \mathcal{M})$.*

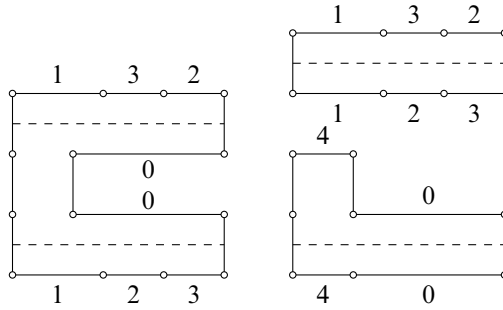

Figure 6: Constructing surfaces satisfying Case 3.III from genus two surfaces

Proof By Theorem 1.4, the only rank two submanifold of $\mathcal{H}(4)$ is $\tilde{\mathcal{Q}}(3, -1^3)$ consisting of translation surfaces that are double coverings of quadratic differentials in $\mathcal{Q}(3, -1^3)$. Thus the corollary follows immediately from Lemma 4.3. \square

4B Case 3.III

As for Case 3.II, the goal of this section is to prove that if a translation surface satisfies this case, then it is always possible to find a translation surface in the affine submanifold \mathcal{M} with at least four cylinders. Before doing so, we describe a surgery that allows us to construct all possible cylinder diagrams satisfying Case 3.III in genus three.

Let M be a translation surface satisfying Case 3.III in a rank two affine manifold \mathcal{M} in genus three. Let C_1 and C_2 be the two homologous cylinders and C_3 be the third one. If we cut M along the core curves of C_1 and C_2 , depicted as dashed lines in Figure 6 (left), then reglue as in Figure 6 (right), we get two translation surfaces in genus two which are horizontally periodic: the first one admits a 1-cylinder diagram denoted by M'_1 ; the second one admits a 2-cylinder diagram and will be denoted by M'_2 . Note that M'_2 contains C_3 .

Lemma 4.5 *If M admits a cylinder decomposition in Case 3.III, then M does not belong to $\mathcal{H}(3, 1)$.*

Proof Note that the singularities of M are also the singularities of M'_1 and M'_2 . Since $M'_i \in \mathcal{H}(2) \cup \mathcal{H}(1, 1)$, the lemma follows. \square

Recall that in genus two there are two 1-cylinder diagrams (one in each stratum) and three 2-cylinder diagrams. By considering all possible combinations, it is possible to produce all possible cylinder diagrams in genus three satisfying Case 3.III.

Since C_1 and C_2 are homologous, they are \mathcal{M} -parallel. If M has two equivalence classes of cylinders, then C_3 is free. We first observe:

Lemma 4.6 *If M is horizontally periodic with two horizontal simple cylinders, or a nonfree simple cylinder, then M does not satisfy Case 3.III.*

Proof Suppose that M satisfies Case 3.III. Using the notations above, we see that at least one of C_1 or C_2 is simple. It follows that the unique horizontal cylinder of M'_1 has one boundary consisting of a single saddle connection, which is impossible since M'_1 has genus two. \square

Lemma 4.7 *If \mathcal{M} is a rank two affine manifold in genus three and \mathcal{M} contains a horizontally periodic translation surface satisfying Case 3.III, and C_3 is a free simple cylinder, then \mathcal{M} contains a horizontally periodic translation surface M' satisfying Case 3.III such that the cylinder $C'_3 \subset M'$ is free and not simple. Furthermore, if C_3 has a double zero on its boundaries, then C'_3 has a double zero on its boundaries as well.*

Proof See Figure 7 for the complete argument of this proof. If C_3 is a simple cylinder, twist it so that there is no vertical saddle connection (from the zero on its top to the zero on its bottom) contained in C_3 . Observe that collapsing C_3 yields a translation surface in the interior of \mathcal{M} because C_3 does not contain any vertical saddle connections, so the distance between every pair of zeros is bounded away from zero.

We define an *extended cylinder deformation* in the following way. The collapse of C_3 determines a path in \mathcal{M} which is a closed line segment ℓ in period coordinates. Therefore, it is natural to consider the real line L in $H^1(X, \Sigma, \mathbb{R} + i\mathbb{R})$ containing this segment. In the case above, the segment and its endpoints lie in the interior of \mathcal{M} , which implies that there is an open subset $U_\ell \subset L$ such that $\ell \subset U_\ell \subset \mathcal{M}$. We call the points in $U_\ell \setminus \ell$ *extended cylinder deformations* of M .

We consider the extended cylinder deformation of C_3 , which realizes the surface depicted on the right side of Figure 7 so that we reach a new translation surface in

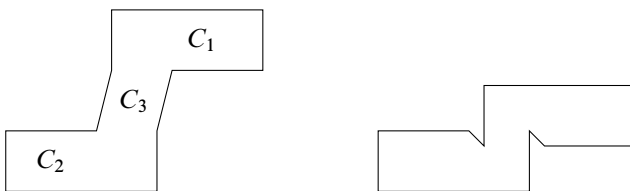

Figure 7: Deformation of translation surface to Case 3.III without a simple cylinder

the interior of \mathcal{M} . Observe that many horizontal trajectories in each of C_1 and C_2 persist under this deformation. However, there is a new horizontal trajectory whose boundary entirely contains the top and bottom boundaries of the cylinders of C_2 and C_1 , respectively. This horizontal trajectory determines a new horizontal cylinder, which we call C'_3 . Since C'_3 can be deformed via the extended deformation of C_3 , C'_3 must also be free. \square

Our goal now is to show:

Proposition 4.8 *Let \mathcal{M} be a rank two submanifold in one of the strata $\mathcal{H}(m, n)$ with $m + n = 4$. Suppose that \mathcal{M} contains a surface M which is horizontally periodic and satisfies Case 3.III. Then \mathcal{M} contains a surface admitting a cylinder decomposition with four cylinders.*

Proof It suffices to assume that $\text{Twist}(M, \mathcal{M}) = \text{Pres}(M, \mathcal{M})$ because otherwise we are done by Lemma 2.4. Since the cylinders must be divided into at least two equivalence classes and C_1 and C_2 are homologous, and thus \mathcal{M} -parallel, C_3 is free. By Lemma 4.7, we can assume that C_3 is not simple. By Lemma 4.5, we only need to consider the case $\mathcal{M} \subset \mathcal{H}(2, 2)$, thus both M'_1 and M'_2 belong to $\mathcal{H}(2)$. Since there is only one 1-cylinder diagram and one 2-cylinder diagram in $\mathcal{H}(2)$, it is easy to check that there is only one cylinder diagram we need to consider, which is shown in Figure 8.

Note that in this diagram, if we cut M horizontally along the top of C_2 and the bottom of C_1 , and reglue the two boundaries of two components, we then get a slit torus M''_1 that contains C_3 , and a surface M''_2 in $\mathcal{H}(2)$ horizontally periodic with a single cylinder. Note that in M''_2 we have a marked horizontal simple closed geodesic c , which corresponds to the slit of M''_1 , and a marked point $x \in c$, which corresponds to the singularity in the boundary of C_3 .

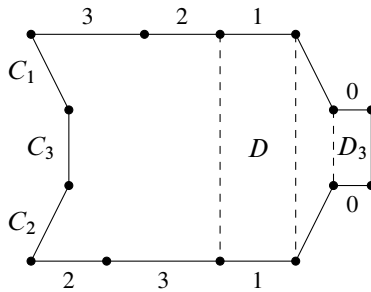

Figure 8: Finding two vertical cylinders in Case 3.III.

Note also that \bar{C}_3 contains a transverse simple cylinder D_3 crossing the saddle connection (0), and it is easy to see that D_3 is free. Twist C_3 as in Figure 8, so that the free simple cylinder D_3 is vertical.

We claim that we can twist $\mathcal{C} = \{C_1, C_2\}$ so that there is another simple vertical cylinder passing exactly once through all three horizontal cylinders. To see this, we consider the splitting of M into the connected sum of M_1'' and M_2'' described above. Let C denote the unique horizontal cylinder in M_2'' . Recall that we have a distinguished core curve c of C and a marked point $x \in c$. Note that the boundary of C consists of three horizontal saddle connections and one can always find two simple cylinders which are disjoint and cross the core curves of C once. Therefore, there always exists a transverse simple cylinder D crossing the core curves of C once whose closure does not contain x . Since simultaneously twisting C_1 and C_2 is the same as twisting C , we can assume D is vertical.

To reconstruct M , we have to cut M_2'' along c and glue the two copies of c with the two sides of the slit in M_1' so that x is identified with both endpoints of the slit. Since x is not contained in the closure of D , we see that D gives rise to a simple cylinder in M crossing all of the horizontal cylinders once and disjoint from D_3 . By a slight abuse of notation, we also denote this cylinder by D .

Using Proposition 2.9, we can assume that M is a square-tiled surface, which is vertically periodic. If M has four vertical cylinders, then we are done. Assume that M has only three vertical cylinders. We claim that all three vertical cylinders are free. Let D' denote the third vertical cylinder. We already have D_3 is free. Since the closures of D and D_3 are disjoint, D_3 is only adjacent to D' . Thus by Lemma 2.10, D' is free, it follows immediately that D is free.

Next, we claim that the cylinder decomposition of M in the vertical direction does not satisfy Case 3.II or Case 3.III. Indeed, if this cylinder decomposition satisfies Case 3.III, then there must be two homologous cylinders, which is impossible as we have three free cylinders. Since Case 3.II is already excluded, we conclude that this cylinder decomposition satisfies Case 3.I. But in Case 3.I, the core curves of the cylinders span a Lagrangian of $H_1(M, \mathbb{Z})$, and we get a contradiction by Lemma 2.15. Thus there must be four vertical cylinders in M . \square

5 Three cylinders: Case 3.I

It turns out that most of the 3-cylinder diagrams satisfy this case. We state the main result of this section here. The proof is given at the end of this section.

Theorem 5.1 *Let \mathcal{M} be a rank two affine manifold in one of the strata $\mathcal{H}(m, n)$ with $m + n = 4$. If \mathcal{M} contains a horizontally periodic translation surface with three cylinders satisfying Case 3.I, then there exists $M \in \mathcal{M}$ horizontally periodic with at least four cylinders.*

Our approach to prove this theorem is by studying horizontally periodic translation surfaces in genus three that satisfy Case 3.I and one of the following two nonexclusive properties:

- (a) There exists $i \in \{1, 2, 3\}$ such that there is a horizontal saddle connection contained in both top and bottom of C_i .
- (b) There exists $i \in \{1, 2, 3\}$ such that C_i is semisimple (see [Definition 5.13](#)).

Though these properties may seem arbitrary, we prove in [Lemma 5.16](#) that there is exactly one 3–cylinder diagram satisfying Case 3.I that does not satisfy one of these properties in strata $\mathcal{H}(m, n)$ with $m + n = 4$. We prove in [Lemma 5.17](#), that the existence of a translation surface satisfying this “exceptional case” in a rank two affine manifold implies the existence of a translation surface in the same affine manifold satisfying one of these two properties.

In light of this fact, it suffices to thoroughly study translation surfaces satisfying at least one of the properties above. We start with the very specific case when two of the cylinders of M are simple; see [Proposition 5.5](#). This serves as an elementary case from which we can build to greater generality. [Proposition 5.6](#) serves as the next step by proving that if M has exactly one nonfree simple cylinder, then \mathcal{M} contains a surface with four cylinders.

If one of the nonfree cylinders of M contains a simple cylinder,³ then \mathcal{M} contains a surface with four cylinders; see [Proposition 5.8](#). Also, if the free cylinder on M is simple, then the same conclusion holds; see [Proposition 5.9](#). These results are summarized in [Proposition 5.10](#), which says that if one of the three cylinders is simple, then \mathcal{M} contains a surface with four cylinders. This leads to [Proposition 5.11](#), which completes the case of surfaces satisfying Property (a), that is, that if M has a cylinder containing a simple cylinder, then \mathcal{M} contains a translation surface with four cylinders.

Finally, [Proposition 5.14](#), which concerns semisimple cylinders, combined with the aforementioned lemmas concerning the exceptional case, completes the proof of [Theorem 5.1](#).

Again we remind the reader that some of the results in this section are written so that they apply to *all 3–cylinder diagrams in genus three* satisfying Case 3.I.

³The phrases “ C contains a simple cylinder” and “ C contains the same saddle connection on its top and bottom” are equivalent, and we pass freely between them.

5A Two simple cylinders

When two of the horizontal cylinders of M are simple, we label them by C_1 and C_2 ; the third one is denoted by C_3 .

Lemma 5.2 *Let \mathcal{M} be a rank two affine manifold in genus three. Let $M \in \mathcal{M}$ be a horizontally periodic translation surface with three cylinders such that C_1 and C_2 are both simple cylinders. Either C_1 and C_2 are \mathcal{M} -parallel or there exists a horizontally periodic in \mathcal{M} with at least four cylinders.*

Proof By Lemma 2.15, we know that C_1, C_2, C_3 cannot be all free. If they all belong to the same equivalence class, then we must have a horizontally periodic surface in \mathcal{M} with more cylinders by Theorem 2.5. Thus we only need to consider the case where C_1, C_2, C_3 fall into two equivalence classes. Note that two simple cylinders cannot be adjacent, therefore the saddle connections in the boundaries of both C_1 and C_2 are included the boundary of C_3 . If C_1 or C_2 is \mathcal{M} -parallel to C_3 , then we only have one equivalence class by Lemma 2.11. Thus C_3 must be free, and C_1 and C_2 are \mathcal{M} -parallel. □

In what follows we will always assume that C_1 and C_2 are \mathcal{M} -parallel, and C_3 is a free cylinder. Let h_i, ℓ_i and t_i denote the height, width (circumference) and twist of C_i , respectively. Denote by a and a' (resp. b and b') the saddle connections in the boundary of C_1 (resp. C_2).

Lemma 5.3 *The cylinders C_1 and C_2 are isometric, that is, they have the same width, height, and twist. Moreover, one can twist C_3 so that any vertical trajectory through C_1 or C_2 passes exactly once through C_3 before closing itself.*

Proof Since C_1 and C_3 are not \mathcal{M} -parallel, we can twist them so that a' is right above a , and $t_1 = 0$ (see Figure 9). It follows that there exists a vertical cylinder C'_1 crossing only C_1 and C_3 such that $C_1 \subset \bar{C}'_1$. Since C_2 is \mathcal{M} -parallel to C_1 , there must be a vertical cylinder C'_2 in the same class as C'_1 passing through C_2 .

Clearly C'_2 can only cross C_2 and C_3 . Let n_i be the number of times C'_2 crosses C_i for $i = 2, 3$. In fact, $n_3 \geq n_2$ because C'_2 cannot pass through C_2 without passing through C_3 . We have $P(C'_1, \{C_3\}) = P(C'_2, \{C_3\})$, which implies

$$\frac{h_3}{h_1 + h_3} = \frac{n_3 h_3}{n_2 h_2 + n_3 h_3}.$$

This simplifies to the relation

$$1 \geq \frac{n_2}{n_3} = \frac{h_1}{h_2}.$$

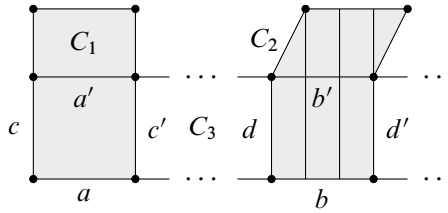

Figure 9: Case 3.I with two simple cylinders; the shaded regions correspond to two slit tori.

If we twist the cylinders C_2 and C_3 to get a vertical cylinder crossing C_2 and C_3 once, and consider the vertical cylinder \mathcal{M} -parallel to it, we get the relation

$$\frac{h_3}{h_2 + h_3} = \frac{n'_3 h_3}{n'_1 h_1 + n'_3 h_3},$$

where $n'_3 \geq n'_1$. However, this forces

$$1 \geq \frac{n'_1}{n'_3} = \frac{h_2}{h_1},$$

which implies $h_1 = h_2$, $n_2 = n_3$ and $n'_1 = n'_3$. But the condition $n_2 = n_3$ can only be satisfied when b' is right above b , which means that if C_3 is twisted so that a' is right above a , then b' is right above b .

Now we prove that C_1 and C_2 are isometric. Let c and c' be the vertical saddle connections in C_3 that join the left endpoints of a' to the left endpoint of a , and the right endpoint of a' to the right endpoint of a respectively. Similarly, let d and d' be the vertical saddle connections in C_3 that join the left endpoints of b' to the left endpoint of b , and the right endpoint of b' to the right endpoint of b , respectively. Note that c and c' (resp. d and d') cut out a slit torus denoted by T_1 (resp. denoted by T_2) which is the closure of C'_1 (resp. C'_2); see Figure 9.

Let D_1 be any simple cylinder in T_1 disjoint from the slit. Then D_1 corresponds to a simple cylinder on M . Note that the complement of D_1 in T_1 is a parallelogram bounded by the borders of D_1 and the pair c, c' . Since C'_2 is \mathcal{M} -parallel to C'_1 , there must exist a cylinder D_2 crossing C'_2 which is \mathcal{M} -parallel to D_1 . We claim that D_2 is contained in T_2 . Indeed, let \mathcal{C}' be the equivalence class of C'_1 and C'_2 ; then we have $\mathcal{C}' = \{C'_1, C'_2\}$ since any cylinder in this equivalence class must cross C_1 or C_2 . We have

$$P(D_1, \mathcal{C}') = 1 \implies P(D_2, \mathcal{C}') = 1,$$

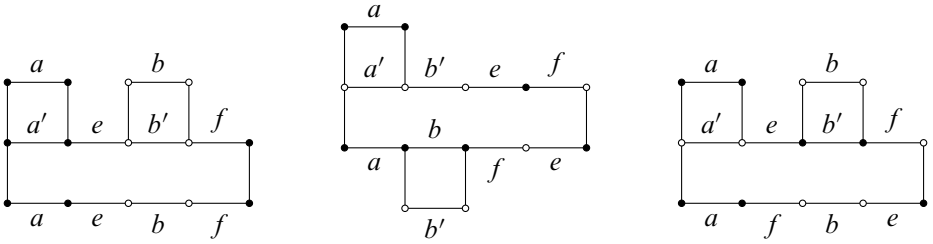

Figure 10: 3-cylinder diagrams with two simple cylinders

which means that D_2 is contained in the union $T_1 \cup T_2$. If D_2 intersects T_1 , since it is parallel to D_1 it must cross both c and c' , thus it cannot be contained in $T_1 \cup T_2$. We derive that D_2 must be contained in T_2 . Moreover, since we have $h_1 = h_2$ and the heights of c and d are both equal to h_3 , it is not difficult to check that

$$\frac{\text{Area}(D_1)}{\text{Area}(T_1)} = \frac{\text{Area}(D_2)}{\text{Area}(T_2)}.$$

We can now use [2, Lemma 8.1] to conclude that T_1 and T_2 are isometric. The lemma is then proved. \square

Remark 5.4 Both Lemmas 5.2 and 5.3 are valid in all strata of genus three.

Proposition 5.5 *Let \mathcal{M} be a rank two affine manifold in genus three in a stratum with two zeros. If $M \in \mathcal{M}$ is a horizontally periodic translation surface satisfying Case 3.I and two of the cylinders are simple, then there is a translation surface in \mathcal{M} with four cylinders.*

Proof A horizontally periodic surface in genus three with two zeros has exactly six horizontal saddle connections. In this case all of the horizontal saddle connections of M are contained in the boundary of C_3 . We have a and a' , and b and b' , in the boundaries of C_1 and C_2 , respectively, and two other ones, denoted by e and f , that are contained in both the top and bottom border of C_3 . We can twist C_3 so that a saddle connection joining the left endpoint of a' to the left endpoint of a is vertical. By Lemma 5.3, we know that b' must lie right above b . It is now easy to check that there are only three diagrams for M , as shown in Figure 10. We also twist C_1 and C_2 so that there are two vertical cylinders C'_1 and C'_2 crossing C_3 once such that $C_i \subset \bar{C}'_i$ for $i = 1, 2$.

- In the left diagram we immediately have four vertical cylinders.

- In the center diagram consider the cylinders E and F that are contained in C_3 and cross only e and f respectively. It is easy to see that E and F are free since any cylinder parallel to E or F must intersect $C'_1 \cup C'_2$. Twisting E in one direction followed by F so that the horizontal trajectories on C_3 persist, we can find a surface in \mathcal{M} close to M with four horizontal cylinders.

- For the right diagram there is a vertical cylinder through e and f which is free. Thus we can freely change lengths of e and f (which are equal). In particular, we can assume that each of C_1 and C_2 are each constructed from a standard square, and C_3 is constructed from the union of four standard squares. Now if we twist C_1 and C_2 by $A = \begin{pmatrix} 1 & 1/3 \\ 0 & 1 \end{pmatrix}$, and C_3 by A^{-1} , then M has a decomposition into four cylinders in the vertical direction.

The proof of the proposition is now complete. □

5B One nonfree simple cylinder

Proposition 5.6 *Let \mathcal{M} be a rank two submanifold in genus three with $k \geq 2$ zeros. Assume that \mathcal{M} contains a surface M admitting a cylinder decomposition in the horizontal direction with three cylinders in Case 3.I. Denote the horizontal cylinders of M by C_1, C_2, C_3 and suppose that C_1 and C_2 are \mathcal{M} -parallel while C_3 is free. If one of the cylinders C_1 or C_2 is simple but the other one is not, then there exists a surface in \mathcal{M} which is horizontally periodic with four cylinders.*

Without loss of generality, we can assume that C_1 is simple but C_2 is not. If C_1 is only adjacent to C_2 , then by Lemma 2.11 all the horizontal cylinders must belong to the same equivalence class. Thus C_1 must be adjacent to C_3 . We first show:

Lemma 5.7 *If C_1 is adjacent to C_3 , then no saddle connection in the top border of C_2 occurs also in its bottom border.*

Proof If such a saddle connection exists, then C_2 contains a vertical simple cylinder D_2 . Let \mathcal{D} denote the equivalence class of D_2 . Since C_1 is \mathcal{M} -parallel to C_2 , there must be a cylinder $D_1 \in \mathcal{D}$ such that $D_1 \cap C_1$ has nonzero area. But C_1 is simple and adjacent to C_3 , hence we have $P(D_1, \{C_3\}) > 0$, while $P(D_2, \{C_3\}) = 0$. We then get a contradiction. □

Proof of Proposition 5.6 We only need to consider two cases:

Case 1 (C_1 is only adjacent to C_3) Let σ denote the saddle connection on the top of C_1 that is contained in the bottom of C_3 . Twisting C_1 and C_3 independently, we can

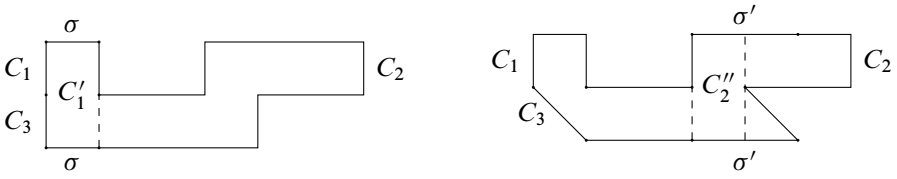

Figure 11: Cylinders in Proposition 5.6, Case 1

get a vertical cylinder C'_1 containing C_1 and crossing C_1 and C_3 only once. There must exist C'_2 crossing C_2 that is \mathcal{M} -parallel to C'_1 . The cylinder C'_2 cannot pass through C_1 , so assume that C'_2 passes n_i times through C_i for $i = 2, 3$. In fact, $n_3 \geq n_2$ because the borders of C_2 are contained in the borders of C_3 . Letting h_i denote the height of C_i for $i = 1, 2, 3$, the equality $P(C'_1, \{C_3\}) = P(C'_2, \{C_3\})$ implies

$$\frac{h_3}{h_1 + h_3} = \frac{n_3 h_3}{n_2 h_2 + n_3 h_3}.$$

It follows that

$$1 \geq \frac{n_2}{n_3} = \frac{h_1}{h_2}.$$

Likewise, it is possible to make a symmetric argument by twisting C_2 and C_3 to get a vertical cylinder C''_2 passing once through C_2 and C_3 (see Figure 11). Then there must exist a cylinder C''_1 crossing C_1 that is \mathcal{M} -parallel to C''_2 . Let C''_1 pass n'_i times through C_i for $i = 1, 2, 3$. Since the top of C_1 is identified to the bottom of C_3 and every saddle connection on the top of C_2 is identified to a saddle connection on the bottom of C_3 , we have the relation $n'_3 \geq n'_1 + n'_2$. The equality $P(C''_1, \{C_3\}) = P(C''_2, \{C_3\})$ implies

$$\frac{n'_3 h_3}{\sum_i n'_i h_i} = \frac{h_3}{h_2 + h_3}.$$

This simplifies to the relation

$$\frac{n'_3 - n'_2}{n'_1} = \frac{h_1}{h_2} \leq 1.$$

However, this implies that $n'_3 \leq n'_1 + n'_2$, which yields $n'_1 + n'_2 = n'_3$, as well as $n_2 = n_3$ and $h_1 = h_2$.

Recall that C'_1 is the vertical cylinder containing C_1 . Let \mathcal{C}' be the equivalence class of C'_1 . Then

$$1 = P(C_2, \mathcal{C}') = P(C_1, \mathcal{C}').$$

Thus, C_2 is filled by cylinders in C' . However, the equality $n_2 = n_3$ implies that no cylinder \mathcal{M} -parallel to C'_1 can pass through C_3 more than once before entering C_2 . We derive that as subsets of the borders of C_3 , the bottom border of C_2 must lie right above the top border of C_2 . Let R_2 be the subset of C_3 which is filled out by vertical trajectories joining saddle connections in the bottom border of C_2 to saddle connections in the top border of C_2 . Note that R_2 is a union of rectangles in C_3 .

Let R_1 denote the rectangle which is the intersection $C'_1 \cap C_3$. Note that R_2 is disjoint from C'_1 . We claim that $R_1 \cup R_2 \subsetneq C_3$. Indeed, if it is the case then any saddle connection in the top border of C_3 is either contained in the bottom border of C_1 or the bottom border of C_2 . Thus we have $c_3 = c_1 + c_2$, where c_i is the core curve of C_i , which contradicts the hypothesis of Case 3.I.

Recall that C_2 is not a simple cylinder. Without loss of generality, let C_2 contain two or more saddle connections on its bottom that are identified to the top of C_3 . It is possible to twist C_2 (and C_1) so that there is a vertical closed trajectory passing once through each of C_2 and C_3 and intersects only one the saddle connections in the bottom of C_2 . Let D_2 denote the cylinder corresponding to this closed trajectory, then D_2 does not fill C_2 .

Let \mathcal{D} be the equivalence class of D_2 . There must exist a vertical cylinder D_1 in \mathcal{D} crossing C_1 . Since C_1 is simple, the union of C_1 and R_1 is a slit torus. Thus D_1 must fill $C_1 \cup R_1$, and we have $P(C_1, \mathcal{D}) = 1$. It follows that $P(C_2, \mathcal{D}) = 1$, and since D_2 does not fill C_2 , there must exist another cylinder D'_2 in \mathcal{D} that crosses C_2 . Thus \mathcal{D} contains at least three vertical cylinders. But \mathcal{D} does not fill C_3 since $R_1 \cup R_2 \subsetneq C_3$. Thus by applying the result of [16], we can conclude that \mathcal{M} contains a vertically periodic surface with at least four vertical cylinders.

Case 2 (C_1 is adjacent to both C_2 and C_3) Without loss of generality, assume the bottom of C_1 , denoted by σ' , is attached to the top of C_2 and the top of C_1 , denoted by σ , is identified to a saddle connection in the bottom of C_3 .

We claim that after appropriate twisting and stretching, there is a cylinder C'_1 passing exactly once through every cylinder. We first twist C_1 and C_2 so that $t_1 = 0$. Let σ'' be a saddle connection on the bottom of C_2 lying below σ' (see Figure 12). By Lemma 5.7, σ'' must be identified to the top of C_3 . Consider a vertical trajectory γ ascending from σ'' through C_2 and C_1 to σ , which passes through σ' and no other saddle connection. Then after twisting C_3 while fixing C_1 and C_2 , we see that the copy of σ in the bottom of C_3 can be arranged so that the trajectory γ after traversing C_3 closes when intersecting σ'' again in the top of C_3 . This determines a cylinder C'_1 as claimed that passes exactly once through C_i for each i .

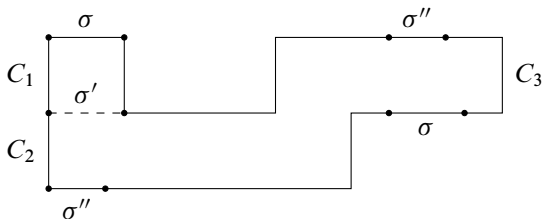

Figure 12: Cylinders in Proposition 5.6, Case 2

Either C'_1 is free or it is not. If C'_1 is not free, then there is a cylinder C'_2 that is \mathcal{M} -parallel to C'_1 . Let h_i denote the height of C_i for all i and let C'_2 pass n_i times through the cylinder C_i . The cylinders C'_1 and C'_2 must satisfy the equality $P(C'_1, \{C_3\}) = P(C'_2, \{C_3\})$, which yields

$$\frac{h_3}{\sum_i h_i} = \frac{n_3 h_3}{\sum_i n_i h_i}$$

and simplifies to

$$n_1 h_1 + n_2 h_2 = n_3 (h_1 + h_2).$$

Some observations are in order. Since every vertical trajectory passing downwards from C_1 enters C_2 , and every vertical trajectory passing downwards from C_2 enters C_3 by Lemma 5.7, we have $n_3 \geq n_2 \geq n_1$. The above equality can be transformed to

$$\left(1 - \frac{n_1}{n_3}\right)h_1 + \left(1 - \frac{n_2}{n_3}\right)h_2 = 0.$$

Noting that $n_1/n_3 \leq 1$, $n_2/n_3 \leq 1$ and obviously $h_1, h_2 > 0$ implies that this equality can only hold if $n_1 = n_2 = n_3$. In other words, any cylinder \mathcal{M} -parallel to C'_1 must pass through every horizontal cylinder an equal number of times.

If there are two cylinders that are \mathcal{M} -parallel to C'_1 , then we are done because we would have a surface vertically periodic with only one equivalence class of three cylinders (by Theorem 2.5). Let \mathcal{C}' be the equivalence class of cylinders \mathcal{M} -parallel to C'_1 . Let h'_i be the height of C'_i for $i = 1, 2$. Let ℓ_i be the circumference of C_i for $i = 1, 2$. Let n be the number of times C'_2 passes through each horizontal cylinder. Letting $n = 0$ is equivalent to saying that C'_1 is free. It will be clear to the reader that a contradiction is achieved regardless of the value of n . We compute the portion $P(C_1, \mathcal{C}') = P(C_2, \mathcal{C}')$, which yields

$$\frac{h'_1 h_1 + n h'_2 h_1}{\ell_1 h_1} = \frac{h'_1 h_2 + n h'_2 h_2}{\ell_2 h_2}.$$

This simplifies to $\ell_1 = \ell_2$, which is clearly a contradiction because C_2 is a simple cylinder whose bottom is identified to the top of C_1 , and so they cannot possibly have equal circumferences without being the same cylinder. \square

5C C_1 or C_2 contains a simple cylinder

Proposition 5.8 *Let \mathcal{M} be a rank two affine manifold in a stratum in genus three with $k \geq 2$ zeros. If $M \in \mathcal{M}$ is a horizontally periodic translation surface satisfying Case 3.I and C_1 or C_2 contains a saddle connection σ on its top and bottom, ie C_1 or C_2 contains a simple cylinder, then there exists a horizontally periodic translation surface $M' \in \mathcal{M}$ that either satisfies Case 3.I and has two simple cylinders, or M' has at least four cylinders.*

In particular, if $k = 2$, then there exists $M' \in \mathcal{M}$ horizontally periodic with four cylinders.

Proof Without loss of generality, let C_1 be the cylinder with a saddle connection σ on its top and bottom. Let C'_1 be the simple cylinder in C_1 which is formed by the trajectories from σ to itself. We can suppose that C'_1 is vertical. We see that C'_1 cannot be free because C_1 is not free. Therefore, there is a cylinder C'_2 that is \mathcal{M} -parallel to C'_1 . [Proposition 2.9](#) guarantees that there is a nearby square-tiled surface on which C'_1 is also a simple vertical cylinder. By a slight abuse of notation, we denote this square-tiled surface by M .

Observe that $C'_2 \subset C_1 \cup C_2$ because it must have zero proportion in C_3 to satisfy the equality $0 = P(C'_1, \{C_3\}) = P(C'_2, \{C_3\})$. Thus, there are at least three vertical cylinders on M . If there are four vertical cylinders then we are done. Therefore, we only need to consider the case where M is decomposed into three cylinders in the vertical direction. Let C'_3 be the third vertical cylinder which necessarily crosses C_3 . Clearly, C'_3 is not \mathcal{M} -parallel to C'_1 and C'_2 .

Consider the cylinder decomposition in the vertical direction. We know that Case 3.II is excluded by [Corollary 4.4](#). Case 3.III can be excluded by noting that C'_1 is a nonfree simple cylinder and that can never occur in Case 3.III ([Lemma 4.6](#)). Therefore, we must be in Case 3.I. If C'_2 is not simple, we conclude by [Proposition 5.6](#). Otherwise, C'_1 and C'_2 are both simple. The final claim follows from [Proposition 5.5](#). \square

5D C_3 is simple

Proposition 5.9 *Let \mathcal{M} be a rank two affine manifold in a stratum in genus three with $k \geq 2$ zeros. If there exists $M \in \mathcal{M}$ which is horizontally periodic satisfying Case 3.I*

such that C_3 is a simple cylinder, then there exists a horizontally periodic translation surface $M' \in \mathcal{M}$ that either satisfies Case 3.I and had two simple cylinders, or M' has at least four cylinders.

In particular, if $k = 2$, then there exists $M' \in \mathcal{M}$ with four cylinders.

Proof We have two cases:

- (C_3 is only adjacent to one of C_1 or C_2) Without loss of generality, assume that C_3 is only adjacent to C_1 , then [Lemma 2.10](#) implies that C_1 is also free, which contradicts the hypothesis that C_1 and C_2 are \mathcal{M} -parallel.
- (C_3 is adjacent to both of C_1 and C_2) We can assume that the top border of C_3 is contained in the bottom border of C_1 and the bottom border of C_3 is contained in the top border of C_2 . If one of C_1 and C_2 contains a saddle connection in both its top and bottom borders, then we are done by [Proposition 5.8](#). Otherwise, the top border of C_1 and the bottom border of C_2 contain the same saddle connections, which means that the core curves of C_1 and C_2 are homologous, thus we have a contradiction to the assumption of Case 3.I. \square

As an immediate consequence, we have:

Proposition 5.10 *Let \mathcal{M} be a rank two invariant submanifold in $\mathcal{H}(m, n)$ with $m + n = 4$. Assume that \mathcal{M} contains a horizontally periodic surface M with three horizontal cylinders in Case 3.I, and one of the cylinders is simple. Then \mathcal{M} contains a horizontally periodic surface with at least four cylinders.*

Proof If all of the horizontal cylinders of M are \mathcal{M} -parallel, then $\text{Twist}(M, \mathcal{M}) \neq \text{Pres}(M, \mathcal{M})$, and we can conclude by [Lemma 2.4](#). By [Lemma 2.15](#) we know that the cylinders cannot be all free. Thus we only need to consider the case where there are two equivalence classes. If there are two simple cylinders, then we can conclude by [Proposition 5.5](#). Suppose that there is only one simple cylinder. If the simple cylinder is \mathcal{M} -parallel to another cylinder, then the proposition follows from [Proposition 5.6](#). Otherwise we have a free simple cylinder, and the proposition follows from [Proposition 5.9](#). \square

Proposition 5.11 *Let \mathcal{M} be a rank two invariant submanifold in $\mathcal{H}(m, n)$ with $m + n = 4$. Assume that \mathcal{M} contains a horizontally periodic surface M with three horizontal cylinders. If there exists a horizontal saddle connection σ that is contained in both top and bottom border of the same cylinder, then \mathcal{M} contains a horizontally periodic surface with four cylinders.*

Proof Let C be the horizontal cylinder that contains σ in both top and bottom borders. There exists a simple cylinder $D \subset C$ crossing only σ . We can suppose that D is vertical. By Lemma 2.14, there exists a square-tiled surface M' close to M on which D is also a vertical simple cylinder, and there are at least two equivalence classes of vertical cylinders. From the proof Lemma 3.3, we derive that M' has at least three vertical cylinders. Assume that M' has exactly three vertical cylinders. Consider the cylinder decomposition in the vertical direction of M' . Recall that Case 3.II is excluded by Corollary 4.4. If this cylinder decomposition satisfies Case 3.III, then we are done by Proposition 4.8, otherwise we are in Case 3.I, and the proposition follows from Proposition 5.10. \square

Remark 5.12 The property of a cylinder containing the same saddle connection on top and bottom is equivalent to saying a cylinder contains a simple cylinder.

5E Semisimple cylinders

Definition 5.13 A cylinder is *semisimple* if the boundary of one side of the cylinder consists of a single saddle connection. Of course, simple cylinders are semisimple. We say that a cylinder is *strictly semisimple* if it is semisimple but not simple.

Proposition 5.14 Let \mathcal{M} be a rank two invariant submanifold in a stratum with exactly two zeros in genus three. If \mathcal{M} contains a horizontally periodic surface M with three horizontal cylinders in Case 3.I and one of the cylinders is strictly semisimple, then there exists $M' \in \mathcal{M}$ with four cylinders.

We first show the following:

Lemma 5.15 Let C and D be two horizontal cylinders in M . Assume that there are two horizontal saddle connections σ_1 and σ_2 such that

- σ_1 is contained in the top boundary of C and in the bottom boundary of D ,
- σ_2 is contained in the bottom boundary of C and in the top boundary of D .

If C and D are not \mathcal{M} -parallel, then there exists in \mathcal{M} a surface M' admitting a cylinder decomposition in the vertical direction with at least one simple vertical cylinder, and two equivalence classes of parallel cylinders.

Proof We can twist C and D so that there exists a simple vertical cylinder V crossing only σ_1 and σ_2 (among the horizontal saddle connections) and contained in $\bar{C} \cup \bar{D}$ (see Figure 13).

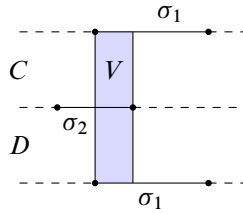

Figure 13

From Proposition 2.9, there exists a surface M' in \mathcal{M} admitting a cylinder decomposition in the vertical direction with a simple cylinder. By Lemma 2.14, we can find such a surface with at least two equivalence classes of vertical cylinders. \square

Proof of Proposition 5.14 We only need to consider the case where the horizontal cylinders of M belong to two equivalence classes. As usual we denote the three horizontal cylinders of M by C_1, C_2, C_3 , where C_1 and C_2 are \mathcal{M} -parallel and C_3 is free. By Proposition 5.11, we can assume that no horizontal saddle connection is contained in both top and bottom of the same cylinder. We will show that there always exist two cylinders that satisfy the conditions of Lemma 5.15.

Case 1 (one of C_1 and C_2 is strictly semisimple) Without loss of generality, we can assume that C_1 is strictly semisimple and the bottom border of C_1 consists of a single saddle connection. We have two subcases:

Case 1(a) (the bottom border of C_1 is included in the top border of C_2) Let σ_1 be a saddle connection in the top border of C_2 , which is not the one in the bottom of C_1 . By the hypothesis that no saddle connection is contained in both top and bottom borders of the same cylinder, we derive that σ_1 must be contained in the bottom border of C_3 . Note also that any saddle connection in the top border of C_3 must be contained in the bottom border of C_2 , since it cannot be contained in the bottom of C_1 nor C_3 . Therefore there is a saddle connection σ_2 in the bottom of C_2 that is contained in the top of C_3 .

Case 1(b) (the bottom border of C_1 is contained in the top border of C_3) By the hypothesis, any saddle in the top of C_3 cannot belong to the bottom of C_3 , thus there exists a saddle connection σ_1 in the top of C_3 that is contained in the bottom of C_2 . By the same assumption, any saddle connection in the top of C_2 either belongs to the bottom of C_1 or C_3 . But the bottom of C_1 is already contained in the top of C_3 , thus there must exist a saddle connection σ_2 in the top of C_2 , which is contained in the bottom of C_3 .

Case 2 (C_3 is semisimple) Without loss of generality, we can assume that the bottom border of C_3 consists of a single saddle connection, which is contained in the top of C_2 . We claim that there exists a saddle connection in the top of C_3 that is contained in the bottom of C_2 . Assume that no saddle connection in the top of C_3 is contained in the bottom of C_2 . Note that, by assumption, all of the saddle connections in the top of C_1 must be contained in the bottom of C_2 . It follows that the top of C_1 and the bottom of C_2 contain the same set of saddle connections, which means that C_1 and C_2 are homologous. Therefore, we have a contradiction to the hypothesis of Case 3.I.

In all cases let V be the vertical simple cylinder crossing each of C_2 and C_3 once, whose existence is guaranteed by Lemma 5.15. Since V does not cross C_1 , there must exist another vertical cylinder V' , which is \mathcal{M} -parallel to V crossing C_1 . By Lemma 2.14, we can find a square-tiled surface close to M on which V and V' persist, V remains simple, and M' has at least two equivalence classes of vertical cylinders. In particular, M' has at least three vertical cylinders. If M' has four vertical cylinders, then we are done. Otherwise, observe that we are not in Case 3.II or Case 3.III since one of the nonfree vertical cylinders is simple. Thus we are in Case 3.I, and we conclude by Propositions 5.6 and 5.9. \square

5F Case 3.I: the exceptional case

Lemma 5.16 *Given a horizontally periodic translation surface $M \in \mathcal{H}(m, n)$ such that M has exactly three cylinders C_1, C_2, C_3 satisfying Case 3.I, there exists exactly one 3-cylinder diagram such that*

- *no horizontal saddle connection is contained in both the top and bottom of the same cylinder, and*
- *none of the C_i is semisimple.*

The unique 3-cylinder diagram satisfying these conditions is given in Figure 14.

Proof Assume that the cylinder decomposition in the horizontal direction of M satisfies the two conditions of the lemma. Let \mathcal{D} be the dual graph of this cylinder decomposition. By definition, \mathcal{D} has three vertices and six edges, any vertex has valency at least four and no loop. Since the total valency of the vertices is 12, all vertices must have valency equal to four. If there is a pair of vertices that are connected by only one edge, then each vertex in this pair is connected to the remaining one by three edges, and we get a contradiction. It follows that any pair of vertices are connected by two edges; this gives us a unique choice for \mathcal{D} .

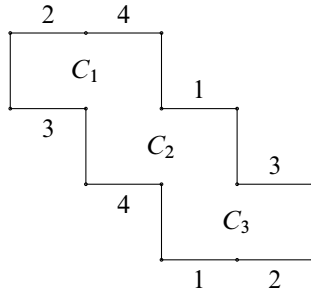

Figure 14: The exceptional 3-cylinder diagram satisfying Case 3.I

To get the cylinder diagram we first need an orientation for each edge. There are only two configurations of the orientations that are not forbidden, and to each of these configurations we have a unique set of compatible cyclic orderings at the vertices. We therefore have two corresponding cylinder diagrams as shown in Figure 15. But in one of the diagrams we have semisimple cylinders. Thus there is only one diagram that satisfies the conditions of the lemma, it is easy to see that this diagram gives a surface in $\mathcal{H}(2, 2)^{\text{odd}}$. \square

We call the translation surface in Figure 14 *the exceptional case*.

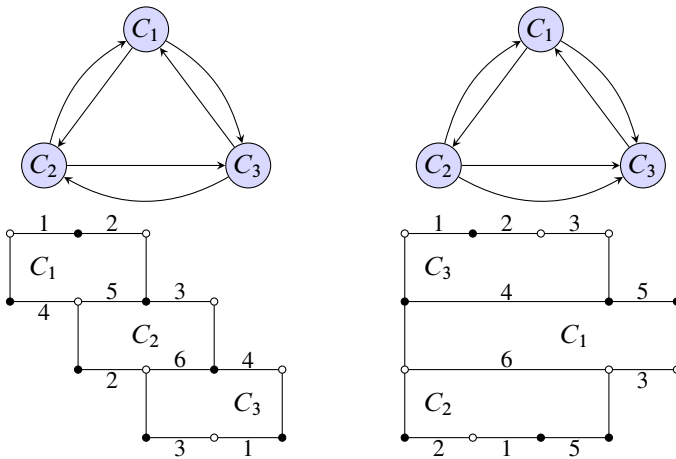

Figure 15: Admissible dual graphs having three vertices with valency equal four and no loop; the one on the right gives a diagram with two semisimple cylinders.

Lemma 5.17 *If a rank two manifold \mathcal{M} contains a horizontally periodic surface with three cylinders arranged in the exceptional case, then \mathcal{M} contains a translation surface with four cylinders.*

Proof It suffices to assume that $\text{Twist}(\mathcal{M}, \mathcal{M}) = \text{Pres}(\mathcal{M}, \mathcal{M})$ by Lemma 2.4, so there are two equivalence classes. Note that in this exceptional case, the combinatorial properties of every cylinder are the same. Thus without loss of generality, we can assume that C_1 and C_2 are \mathcal{M} -parallel and C_3 is free.

Observe that the hypothesis of Lemma 5.15 is satisfied. Thus, \mathcal{M} contains a translation surface M containing a vertical simple cylinder V crossing C_2 and C_3 . Since V does not cross C_1 , there must exist another vertical cylinder V' in the equivalence class of V that crosses C_1 . By Proposition 2.9, we can find in a neighborhood of M in \mathcal{M} a square-tiled surface on which V and V' persist, and V remains simple. By Lemma 2.14, we get another square-tiled surface M'' close to M' (hence M'' satisfies the same properties regarding V and V'), on which we have at least two equivalence classes of vertical cylinders. In particular, M'' has at least three vertical cylinders. Since we have one simple cylinder that is not free, we are not in Case 3.III. Since Case 3.II is excluded by Lemma 4.3, we conclude that the cylinder decomposition in the vertical direction of M'' satisfies Case 3.I. Therefore, the lemma follows from Proposition 5.10. \square

Proof of Theorem 5.1 By Lemma 5.16, every cylinder diagram satisfying Case 3.I either has a cylinder containing a simple cylinder, has a cylinder which is semisimple, or satisfies the exceptional case.

By Proposition 5.14, if a translation surface with three cylinders in \mathcal{M} satisfies Case 3.I and has a strictly semisimple cylinder, then either there is a translation surface in \mathcal{M} with four cylinders and we are done, or there is a translation surface satisfying Case 3.I with two simple cylinders. In the latter case, we can conclude by Proposition 5.5. If the translation surface has a simple cylinder, then we conclude by Propositions 5.6 and 5.9, which address every possibility for a simple cylinder in the cylinder diagram.

If one of the cylinders contains a simple cylinder, then we conclude by Proposition 5.11.

Finally, if the cylinder diagram satisfies the exceptional case, then we conclude by Lemma 5.17. \square

Corollary 5.18 *Let \mathcal{M} be a rank two invariant submanifold in one of the strata $\mathcal{H}(m, n)$ with $m + n = 4$. Then \mathcal{M} contains a horizontally periodic surface with four cylinders.*

6 Rank two invariant submanifolds in $\mathcal{H}(m, n)$, $m + n = 4$

6A 4-cylinder diagrams in $\mathcal{H}(m, n)$, where $m + n = 4$

The following lemma is valid for all translation surfaces in genus three.

Lemma 6.1 *If a translation surface M in genus three decomposes into four cylinders, then pinching the core curves of those cylinders degenerates the surface (in the sense of Lemma 4.1) to one of four possible surfaces:*

- (4.I) *Two spheres joined by four pairs of simple poles.*
- (4.II) *Two spheres joined by two pairs of simple poles such that each sphere has a pair of simple poles.*
- (4.III) *Two spheres joined by three pairs of simple poles such that one sphere carries an additional pair of simple poles.*
- (4.IV) *Two spheres and a torus such that the spheres have three simple poles and the torus has two simple poles.*

If $M \in \mathcal{H}(m, n)$, then Case 4.IV cannot occur.

Proof The core curves of the four cylinders must always be linearly dependent in homology in genus three. This implies that the degenerate surface must have at least two parts. There must be at least two pairs of poles between the parts because the core curve of a cylinder is never a separating curve for an abelian differential. If the two remaining pairs of poles were on the same part, then this would be impossible in genus three because every sphere must have at least three simple poles. If each pair of poles lies on a different part, this yields Case 4.II.

If there are three pairs of poles between the two parts, then the other pair of poles lies on one of the parts which implies that both parts have genus zero and all pairs of poles are accounted for. This yields Case 4.III.

If there are four pairs of poles between the two parts, then all of them are accounted for, and the surface satisfies Case 4.I.

Next we consider the case of three parts. Each part must have at least two simple poles, which accounts for at least three of the four pairs of poles. If the fourth cylinder were contained on a single part, then the condition that a sphere must carry at least three simple poles implies that we would have a surface of genus greater than three. Hence, the fourth cylinder lies between two parts, and the only part with two simple poles is forced to be a torus. This is exactly Case 4.IV.

Finally, there cannot be four parts with four pairs of poles in genus three.

Since each part must contain a zero, if $M \in \mathcal{H}(m, n)$, then we only have two parts, which means that Case 4.IV cannot occur. \square

Conventions and notation • In what follows, we denote by c_i a core curve of C_i and by α_i the corresponding element in $(T_M^{\mathbb{R}}\mathcal{M})^*$, and $h(C_i)$, $w(C_i)$ and $t(C_i)$ are the height, width (circumference) and twist of C_i . We sometimes write h_i , w_i and t_i instead of $h(C_i)$, $w(C_i)$ and $t(C_i)$.

- By “twisting” or “shearing” a family of cylinders, we will mean applying a matrix $\begin{pmatrix} 1 & t \\ 0 & 1 \end{pmatrix}$ or $\begin{pmatrix} 1 & 0 \\ 0 & e^s \end{pmatrix}$ to each cylinder in this family, and keeping the other cylinders unchanged.

- Let us suppose that M is horizontally periodic, and denote by C_1, \dots, C_n its horizontal cylinders. For each $i \in \{1, \dots, n\}$, we pick a saddle connection s_i contained in C_i joining a zero in the bottom border and a zero in the top border of C_i . Note that every element of $H^1(M, \Sigma, \mathbb{R})$ is completely determined by its values on the s_i and the horizontal saddle connections. Let ζ_i be the element in $H^1(M, \Sigma; \mathbb{R})$ satisfying $\zeta_i(s_j) = \delta_{ij}$ and $\zeta_i(s) = 0$ for any horizontal saddle connection s on M . Twisting a cylinder C_i gives a path in the stratum; the tangent vector to this path is $h_i \zeta_i$. If we twist a family of cylinders C_{i_1}, \dots, C_{i_k} simultaneously, then the tangent vector to the corresponding path in the stratum is given by $v = h_{i_1} \zeta_{i_1} + \dots + h_{i_k} \zeta_{i_k}$. Note that ζ_i vanishes on all the core curves of the horizontal cylinders.

6B $\mathcal{H}(3, 1)$

We first observe:

Lemma 6.2 *If M is a horizontally periodic translation surface with four cylinders in $\mathcal{H}(3, 1)$, then M satisfies Case 4.III.*

Proof By the formula for the degree of the canonical bundle, $\#(\text{zeros}) - \#(\text{poles}) = 2g' - 2$, where g' is the genus of a part of a degenerate Riemann surface and $\#(\cdot)$ is the sum of the orders of the elements in the set. By inspection of the parts of the surface for each of the degenerate surfaces in Lemma 6.1, and by counting the total order of the poles on each part of the degenerate surface, we immediately see that only the sphere carrying five simple poles in Case 4.III can admit a zero of order three because the formula above would read $3 - 5 = -2$. Therefore, it is the only possible case in $\mathcal{H}(3, 1)$. \square

From Proposition A.1, we have:

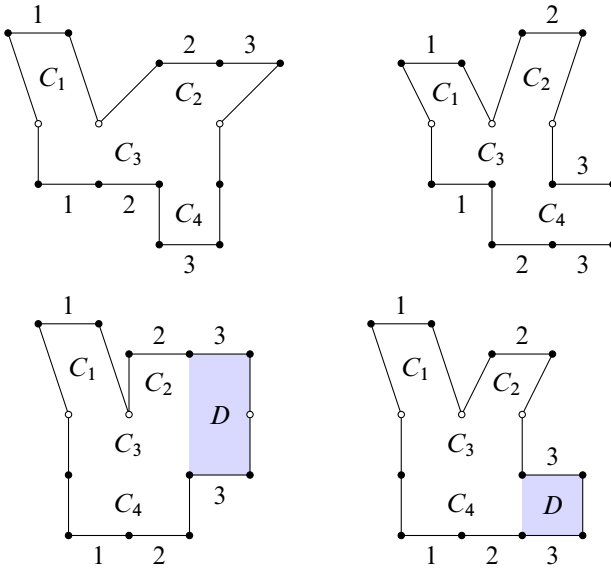

Figure 16: 4–cylinder diagrams in $\mathcal{H}(3, 1)$, Cases 4.III.UA (top left), 4.III.UB (top right), 4.III.UC (bottom left) and 4.III.UD (bottom right)

Lemma 6.3 *Let M be a horizontally periodic surface in $\mathcal{H}(3, 1)$. If M has four horizontal cylinders, then the cylinder decomposition in the horizontal direction is given by one of the diagrams in Figure 16.*

Theorem 6.4 *There are no rank two affine manifolds in $\mathcal{H}(3, 1)$.*

Proof Let \mathcal{M} be an invariant rank two submanifold in $\mathcal{H}(3, 1)$. By Corollary 5.18, \mathcal{M} contains a horizontally periodic surface with four cylinders. From Lemma 6.3, the cylinder decomposition of \mathcal{M} is given by one of the diagrams in Figure 16.

Since a horizontally periodic surface in $\mathcal{H}(3, 1)$ has at most four horizontal cylinders, Theorem 2.5 implies that the cylinders of \mathcal{M} must fall into at least two equivalence classes. We will find a contradiction for each of these diagrams. In what follows, we refer to Figure 16 for notations and details of the proofs.

Case 4.III.UA Observe that we have $c_3 = c_1 + c_2 \in H_1(M, \mathbb{Z})$. Therefore, if two of C_1, C_2, C_3 are \mathcal{M} –parallel, then they all belong to the same equivalence class. Consequently, if there are exactly two equivalence classes, then the classes must be $\{C_1, C_2, C_3\}$ and $\{C_4\}$. But from Lemma 2.11, we know that C_1 and C_3 are not \mathcal{M} –parallel. Thus there must be at least three equivalence classes. In particular, either C_1 or C_2 is free.

Assume that C_1 is free. We can then collapse it so that there is a unique saddle connection that crosses C_1 that is reduced to a point. The resulting surface M' is contained in $\mathcal{H}(4)$. By Proposition 2.16 and Theorem 1.4, it follows that M' is contained in $\tilde{\mathcal{Q}}(3, -1^3) \subset \mathcal{H}(4)^{\text{odd}}$. But a surface in $\tilde{\mathcal{Q}}(3, -1^3)$ does not admit the cylinder diagram of M' since there must exist an involution that fixes one cylinder and exchanges the other two; see [2, Case (O4)].

If C_2 is free, then we can twist it by an appropriate amount and collapse it to get a surface in $\mathcal{H}(4)^{\text{hyp}}$. But the arguments above show that this is also impossible. Thus we get a contradiction, which means that the cylinder diagram of M cannot be in Case 4.III.UA.

Case 4.III.UB Again we have $c_3 = c_1 + c_2 \in H_1(M, \mathbb{Z})$, and C_1 cannot be \mathcal{M} -parallel to C_3 . It follows that there are at least three equivalence classes. We claim that C_2 must be free. Indeed, since C_1 and C_3 do not belong to the same equivalence class, C_2 is \mathcal{M} -parallel to neither C_1 nor C_3 . Note that C_4 contains a transverse simple cylinder thus C_2 is not \mathcal{M} -parallel to C_4 by Lemma 2.12. We can then conclude that C_2 is free. Collapse C_2 so that the two singularities of M collide, we then get a surface in $\mathcal{H}^{\text{hyp}}(4)$. But this is a contradiction with Proposition 2.16, since we have no rank two invariant submanifolds in $\mathcal{H}^{\text{hyp}}(4)$.

Case 4.III.UC We first claim that C_2 and C_3 are not \mathcal{M} -parallel. Note that there always exists a transverse cylinder D which is contained in $\bar{C}_2 \cup \bar{C}_3$ crossing the saddle connection number 3. We can assume that D is vertical. Let \mathcal{C} be the equivalence class of C_2 . If \mathcal{C} contains C_3 , then it also contains C_1 . Since we have at least two equivalence classes of horizontal cylinders, C_4 must be free. There must exist a vertical cylinder D' in the equivalence class of D that crosses C_1 . But such a cylinder also crosses C_4 , which is a contradiction since $P(D, \{C_4\}) = 0$.

We now claim that C_2 and C_4 are not \mathcal{M} -parallel. Assume by contradiction that this is the case, then C_1 and C_3 must be free. Let D be the vertical cylinder through C_2 and C_3 constructed above. There must exist a vertical cylinder D' in the equivalence class of D that crosses C_4 . Since that D does not cross C_1 , neither does D' . Let n_i , $i = 2, 3, 4$, be the number of times D' crosses C_i . It is easy to see that we have $n := n_2 = n_3 = n_4$. It follows that

$$P(D', \{C_3\}) = \frac{h_3}{h_2 + h_3 + h_4}, \quad \text{while} \quad P(D, \{C_3\}) = \frac{h_3}{h_2 + h_3}.$$

Thus we cannot have $P(D, \{C_3\}) = P(D', \{C_3\})$ unless $h_4 = 0$, which is impossible. We can now conclude that C_2 is free. Collapsing C_2 so that a single saddle connection is reduced to a point gives us a surface M' in $\mathcal{H}^{\text{odd}}(4)$ which admits no involution acting

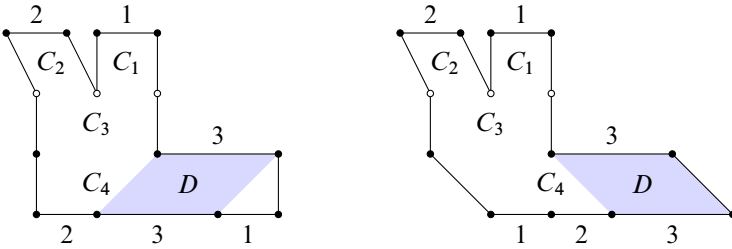

Figure 17: The two deformations in the proof of Case 4.III.UD

by $-\text{Id}$ on the flat metric structure. But by Proposition 2.16, this surface must belong to $\tilde{\mathcal{Q}}(3, -1^3)$. We again have a contradiction, which means that this case cannot occur.

Case 4.III.UD If there are three equivalence classes of horizontal cylinders or more, either C_1 or C_2 must be free. In both cases, by collapsing a free simple cylinder gives us a surface in $\mathcal{H}^{\text{odd}}(4)$ but not in $\tilde{\mathcal{Q}}(3, -1^3)$. Thus the horizontal cylinders must fall into two equivalence classes, which are $\mathcal{C} := \{C_1, C_2, C_3\}$ and $\{C_4\}$.

Let C_i have height h_i for all i . Let $\ell(k)$ denote the length of the saddle connection labeled by k . Let D be the simple cylinder in C_4 whose core curves only cross the saddle connection 3 (see Figure 17). Observe that D is free, since any other cylinder parallel to D must cross C_3 . We can stretch the cylinder D so that $\ell(3) \geq \ell(1) + \ell(2)$. Depending on whether $h_1 \geq h_2$ or $h_1 \leq h_2$, we perform one of the following deformations, depicted in Figure 17: If $h_2 \geq h_1$, then twist \mathcal{C} and C_4 so that C_2 lies directly over 2 in the bottom of C_4 , and C_1 lies directly over 3 in the bottom of C_4 . If $h_2 \leq h_1$, then twist \mathcal{C} and C_4 so that C_1 lies directly over 1 in the bottom of C_4 , and C_2 lies directly over 3 in the bottom of C_4 . We consider only the case where $h_2 \geq h_1$.

By Proposition 2.9, there is a vertical cylinder D_1 passing through C_2, C_3 and C_4 whose closure contains C_2 . Since C_1 is parallel to C_2 and D_1 does not intersect C_1 , there is a vertical cylinder D_2 that is \mathcal{M} -parallel to D_1 and intersects C_1 . Let D_1 pass n times through each of C_2, C_3 and C_4 . Let D_2 pass n_i times through C_i for $i \in \{1, 3, 4\}$. Clearly D_2 does not pass through C_2 . Some observations are in order. Note that all trajectories in D_2 ascending from C_3 enter C_1 , and all trajectories ascending from C_1 enter C_4 followed eventually by C_3 . Hence, $n_1 = n_3$. The assumption that C_1 lies directly over saddle connection 3 combined with the assumption that $\ell(3) \geq \ell(1) + \ell(2)$ implies $n_4 > n_1$. Then $P(D_1, \{C_4\}) = P(D_2, \{C_4\})$ implies

$$\frac{nh_4}{n(h_2 + h_3 + h_4)} = \frac{n_4h_4}{n_1h_1 + n_3h_3 + n_4h_4},$$

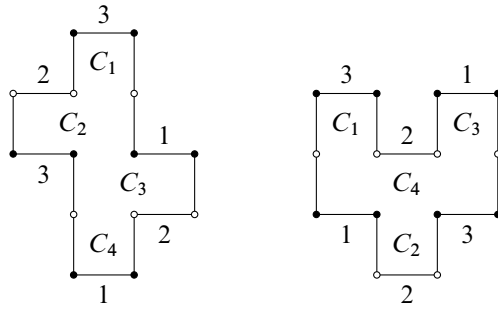

Figure 18: The two 4-cylinder diagrams in $\mathcal{H}^{\text{hyp}}(2, 2)$; Cases 4.I.HA (left) and 4.I.HB (right)

which simplifies to

$$(n_4 h_2 - n_1 h_1) + (n_4 - n_1) h_3 = 0.$$

Since we have $h_2 \geq h_1$ by assumption, this equation holds only if $n_4 = n_1$, which is a contradiction. Thus, \mathcal{M} contains no horizontally periodic surface with four cylinders.

The proof of the theorem is now complete. □

Remark 6.5 In all of the cases above, the rank two property was obvious after collapsing cylinders even without the use of [Proposition 2.16](#).

Remark 6.6 Also, the degeneration argument itself was unnecessary in these cases because in each case there was a Lagrangian subspace of equivalence classes prelimit.

6C $\mathcal{H}^{\text{hyp}}(2, 2)$

As a direct consequence of [Proposition A.1](#), we have the following:

Lemma 6.7 *There are two 4-cylinder diagrams in $\mathcal{H}^{\text{hyp}}(2, 2)$, and they are pictured in [Figure 18](#).*

Let us now show:

Lemma 6.8 *If \mathcal{M} is a rank two manifold in $\mathcal{H}^{\text{hyp}}(2, 2)$, then \mathcal{M} contains the horizontally periodic translation surface M satisfying Case 4.I.HA.*

Proof By [Lemma 6.7](#), both 4-cylinder diagrams in $\mathcal{H}^{\text{hyp}}(2, 2)$ satisfy Case 4.I. Note that the horizontal cylinders of M must fall into at least two equivalence classes by

Theorem 2.5. We will show that M cannot satisfy Case 4.I.HB. Let C_1, C_2, C_3 denote the simple cylinders and C_4 the largest one. Since we have the relation $c_1 + c_2 + c_3 = c_4$, if all of the simple cylinders belong to the same equivalence class, then this equivalence class also contains C_4 , and we have a contradiction to the assumption that there are at least two equivalence classes. If one of the simple cylinders is \mathcal{M} -parallel to C_4 , then [Lemma 2.11](#) implies that there is only one equivalence class. Thus, we derive that there is at least a free simple cylinder.

Collapsing a simple cylinder so that the zeros collide yields a translation surface in $\mathcal{H}^{\text{hyp}}(4)$. By [Proposition 2.16](#), this surface must belong to a rank two invariant submanifold of $\mathcal{H}^{\text{hyp}}(4)$. But there is no rank two affine manifold in $\mathcal{H}^{\text{hyp}}(4)$ by [Theorem 1.4](#). Therefore, Case 4.I.HB does not occur for surfaces in a rank two invariant submanifold of $\mathcal{H}^{\text{hyp}}(2, 2)$. \square

Lemma 6.9 *If M satisfies Case 4.I.HA and its orbit closure \mathcal{M} has rank two, then there are two equivalence classes of cylinders: $\mathcal{C} = \{C_1, C_4\}$ and $\mathcal{C}' = \{C_2, C_3\}$.*

Proof Again by [Theorem 2.5](#), we know that there are at least two equivalence classes of horizontal cylinders. We first notice that the simple cylinders cannot be free, otherwise by collapsing such a cylinder so that the zeros collide, we get a surface in $\mathcal{H}^{\text{hyp}}(4)$ whose orbit closure is a rank two invariant submanifold by [Proposition 2.16](#). In particular, we derive that C_1 and C_4 are not free. If C_1 is \mathcal{M} -parallel to C_2 , then we only have one equivalence class by [Lemma 2.11](#), thus C_1 and C_2 are not \mathcal{M} -parallel. By the same argument, C_3 and C_4 are not \mathcal{M} -parallel.

Assume that C_1 and C_3 are \mathcal{M} -parallel. Since C_4 is not free and not \mathcal{M} -parallel to C_1 , it must be \mathcal{M} -parallel to C_2 . But since we have the relation $c_1 + c_3 = c_2 + c_4 \in H_1(M, \mathbb{Z})$, this would imply that C_3 and C_4 are \mathcal{M} -parallel, thus there is only one equivalence class. Hence, we derive that C_1 and C_4 must be \mathcal{M} -parallel.

It remains to show that C_2 and C_3 are \mathcal{M} -parallel. Twist C_1 and C_2 independently so that there is a vertical cylinder D contained in $\bar{C}_1 \cup \bar{C}_2$ crossing the saddle connection 3. There must exist another vertical cylinder D' in the equivalence class of D that crosses C_4 . Clearly D' must cross C_3 . If C_3 is free then $P(D, \{C_3\}) = 0$, while $P(D', \{C_3\}) > 0$. Thus, we must have C_2 and C_3 are \mathcal{M} -parallel. The lemma is then proved. \square

Lemma 6.10 *If M satisfies Case 4.I.HA and its orbit closure \mathcal{M} has rank two, then M admits a double covering to a half-translation surface in $\mathcal{Q}(1^2, -1^2)$.*

Proof By Lemma 6.9, the two equivalence classes must be $\mathcal{C} = \{C_1, C_4\}$ and $\mathcal{C}' = \{C_2, C_3\}$. We prove that this surface must admit a double covering to a half-translation surface in the stratum $\mathcal{Q}(1^2, -1^2)$. Twist every cylinder in the equivalence classes of the cylinders C_1 and C_2 (which are in different equivalence classes) to get a vertical cylinder V_1 through saddle connection 3. This cylinder will contain C_1 , but it does not pass through C_4 and C_3 . Therefore, there must be a cylinder V_2 that is \mathcal{M} -parallel to V_1 that crosses C_4 , hence C_3 .

Note that V_2 does not cross C_1 . For all i , let V_2 pass n_i times through C_i . We have $n_3 = n_2 + n_4$. Let the height of C_i be h_i for all i and compute

$$P(V_1, \mathcal{C}) = P(V_2, \mathcal{C}) \implies \frac{h_1}{h_1 + h_2} = \frac{n_4 h_4}{n_2 h_2 + n_3 h_3 + n_4 h_4},$$

which implies

$$\frac{h_4}{h_1} = \frac{n_2 h_2 + n_3 h_3}{n_4 h_2} \geq \frac{n_3 h_3}{n_4 h_2}.$$

Similarly, if we twist C_3 and C_4 to get a vertical cylinder V'_1 through the saddle connection 1 containing C_4 , then there is a cylinder V'_2 that is \mathcal{M} -parallel to V'_1 through C_1 . Let V'_2 pass n'_i times through C_i . Note that $n'_4 = 0$ and $n'_2 = n'_1 + n'_3$. We then have

$$P(V'_1, \mathcal{C}) = P(V'_2, \mathcal{C}) \implies \frac{h_4}{h_3 + h_4} = \frac{n'_1 h_1}{n'_1 h'_1 + n'_2 h_2 + n'_3 h_3},$$

which simplifies to

$$\frac{h_1}{h_4} = \frac{n'_2 h_2 + n'_3 h_3}{n'_1 h_3} \geq \frac{n'_2 h_2}{n'_1 h_3}.$$

Combining these two inequalities yields

$$1 = \frac{h_4 h_1}{h_1 h_4} \geq \frac{n_3 n'_2}{n_4 n'_1} \geq 1$$

because $n_3 \geq n_4$ and $n'_2 \geq n'_1$. The equality occurs if and only if $n_2 = n'_3 = 0$, which implies that $h_1/h_4 = h_2/h_3$, and V_2 must be entirely contained in C_3 and C_4 . In particular, it cannot pass through the saddle connection 2, and this is only possible if 2 lies directly over itself. This means exactly that if the sides of C_2 are twisted so that they are vertical, then C_3 must also have vertical sides.

Moreover, there must be a vertical cylinder V passing vertically from 2 to itself that is contained entirely in C_2 and C_3 . Note that V is free. From the relation $P(C_2, \{V\}) = P(C_3, \{V\})$ we derive that $w(C_2) = w(C_3)$ and $w(C_1) = w(C_4)$, where $w(C_i)$ is the circumference of C_i .

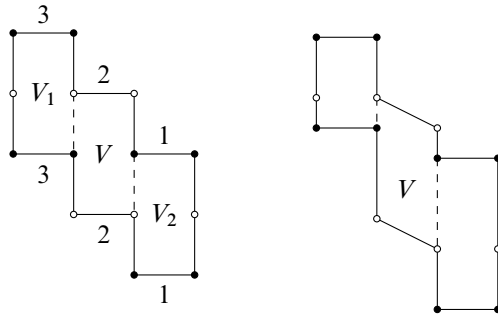

Figure 19: Proof of Lemma 6.10

Without loss of generality, let $h_3 \geq h_2$. Twist V as in Figure 19, so that the zeros v_1 and v_2 lie on the same horizontal saddle connection. In fact, if $h_3 > h_2$, then there will be exactly one horizontal saddle connection joining v_1 and v_2 in V . Therefore, if we collapse V , we would degenerate to a rank two orbit closure by Proposition 2.16 in $\mathcal{H}^{\text{hyp}}(4)$, which does not exist. Such a contradiction implies that we must indeed have $h_3 = h_2$, which in turn implies $h_1 = h_4$.

We now show that C_1 and C_4 have the same twist. Let us twist C_1 and C_2 so that the vertical cylinder V_1 exists. Assume that the twist of C_4 is nonzero. In this case collapsing C_1 and C_4 simultaneously only destroys a single saddle connection (which is contained in C_1). Thus, the resulting surface belongs to $\mathcal{H}^{\text{hyp}}(4)$. Since such a surface must be contained in a rank two invariant submanifold by Proposition 2.16, we then get a contradiction. Therefore the twist of C_4 must be zero, which means that C_1 and C_4 are isometric.

Observe now that we have an involution of M that sends C_1 and C_2 to C_4 and C_3 , respectively. This involution fixes the two singularities of M and two other points. Thus M is the double covering of a quadratic differential in $\tilde{\mathcal{Q}}(1^2, -1^2)$. \square

Theorem 6.11 *The Prym locus $\tilde{\mathcal{Q}}(1^2, -1^2)$ is the unique rank two invariant submanifold in $\mathcal{H}^{\text{hyp}}(2, 2)$.*

Proof By Corollary 5.18 and Lemma 6.8, every rank two invariant submanifold \mathcal{M} in $\mathcal{H}^{\text{hyp}}(2, 2)$ contains a horizontally periodic translation surface M satisfying Case 4.I.HA. Lemma 6.10 implies that M is contained in the Prym locus $\tilde{\mathcal{Q}}(1^2, -1^2)$. Set $V := T_M^{\mathbb{R}}\mathcal{M}$ and $W := T_M^{\mathbb{R}}\tilde{\mathcal{Q}}(1^2, -1^2)$. In what follows, we identify M with a point in $H^1(M, \Sigma, \mathbb{R} + \iota\mathbb{R})$. Pick any vector $v \in V$; for $\varepsilon > 0$ small enough, $M + \varepsilon v$ is also a surface in \mathcal{M} admitting a cylinder decomposition in the horizontal direction with the same diagram. Lemma 6.10 applied to $M + \varepsilon v$ then implies that

$M + \varepsilon v \in \tilde{Q}(1^2, -1^2)$. Thus we can conclude that $V \subset W$ and $\mathcal{M} \subset \tilde{Q}(1^2, -1^2)$. Moreover,

$$\dim_{\mathbb{C}} \mathcal{M} = \dim_{\mathbb{R}} V \leq \dim_{\mathbb{R}} W = \dim_{\mathbb{C}} \tilde{Q}(1^2, -1^2) = 4.$$

But since \mathcal{M} has rank two, by definition its dimension is at least four. Hence we have $\dim_{\mathbb{C}} \mathcal{M} = \dim_{\mathbb{C}} \tilde{Q}(1^2, -1^2)$, and consequently $\mathcal{M} = \tilde{Q}(1^2, -1^2)$. The proof of the theorem is now complete. \square

Lemma 6.12 *The locus $\tilde{Q}(1^2, -1^2)$ is also the set $\tilde{\mathcal{H}}_{(2,2)}^{\text{hyp}}(2)$ of unramified double coverings of $\mathcal{H}(2)$ in $\mathcal{H}^{\text{hyp}}(2, 2)$.*

Proof Recall that by definition $M = (X, \omega)$, where X is a Riemann surface of genus three, and ω is a holomorphic 1-form on X having two double zeros. For any $M = (X, \omega) \in \tilde{Q}(1^2, -1^2) \subset \mathcal{H}^{\text{hyp}}(2, 2)$ we have two involutions on X : the hyperelliptic one denoted by ι and the another one coming from the double covering of a quadratic differential in $Q(1^2, -1^2)$ denoted by τ . Set $\vartheta := \iota \circ \tau$, which is also an involution since ι commutes with all the automorphisms of X .

Set $Y := X/\langle \vartheta \rangle$. By definition, $\iota^* \omega = \tau^* \omega = -\omega$, thus $\omega \in \ker(\vartheta - \text{Id}) \subset \Omega(X)$, where $\Omega(X)$ is the space of holomorphic 1-forms on X . Note that $\dim_{\mathbb{C}} \ker(\vartheta - \text{Id}) = \dim_{\mathbb{C}} \ker(\tau + \text{Id}) = 2$, therefore Y is a surface of genus two and ω arises from a holomorphic 1-form η on Y .

Let $\pi: X \rightarrow Y$ be the double covering induced by ϑ . Since Y has genus two, the Riemann–Hurwitz formula then implies that π is unramified. It follows that η has a double zero on Y , that is $(Y, \eta) \in \mathcal{H}(2)$. Therefore, $\tilde{Q}(1^2, -1^2) \subset \tilde{\mathcal{H}}_{(2,2)}^{\text{hyp}}(2)$. Since $\tilde{\mathcal{H}}_{(2,2)}^{\text{hyp}}(2)$ is clearly a rank two invariant submanifold of $\mathcal{H}^{\text{hyp}}(2, 2)$, from [Theorem 6.11](#) we can conclude that $\tilde{\mathcal{H}}_{(2,2)}^{\text{hyp}}(2) = \tilde{Q}(1^2, -1^2)$. \square

6D $\mathcal{H}^{\text{odd}}(2, 2)$

Our goal is to show the following:

Theorem 6.13 *Let \mathcal{M} be a rank two affine manifold of $\mathcal{H}^{\text{odd}}(2, 2)$. Then we have one of*

$$\begin{cases} \dim_{\mathbb{C}} \mathcal{M} = 5 & \text{and } \mathcal{M} = \tilde{Q}(4, -1^4), \\ \dim_{\mathbb{C}} \mathcal{M} = 4 & \text{and } \mathcal{M} = \tilde{\mathcal{H}}_{(2,2)}^{\text{odd}}(2), \end{cases}$$

where $\tilde{\mathcal{H}}_{(2,2)}^{\text{odd}}(2)$ is the locus of unramified double covers of surfaces in $\mathcal{H}(2)$ in $\mathcal{H}^{\text{odd}}(2, 2)$.

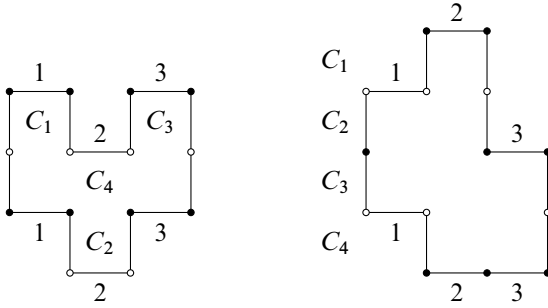

Figure 20: $\mathcal{H}^{\text{odd}}(2, 2)$, Cases 4.I.OA (left) and 4.I.OB (right)

By Corollary 5.18, we know that \mathcal{M} contains a horizontally periodic surface with four cylinders. The following lemma is a direct consequence of Proposition A.1:

Lemma 6.14 *The 4-cylinder diagrams in $\mathcal{H}^{\text{odd}}(2, 2)$ satisfy one of the following five cases: 4.I.OA, 4.I.OB, 4.II.OA, 4.II.OB or 4.II.OC, as shown in Figures 20 and 21.*

We will consider each of the diagrams listed in Lemma 6.14. Theorem 6.13 will follow from Lemmas 6.15–6.19. Throughout, it is important to note that if $\mathcal{M} \subset \mathcal{H}(2, 2)$ has rank two, then $\dim_{\mathbb{C}}(\mathcal{M}) \leq 5$.

6D1 Case 4.I.OA

Lemma 6.15 *Let M be a horizontally periodic translation surface in a rank two affine manifold \mathcal{M} . If M satisfies Case 4.I.OA, then $\mathcal{M} = \tilde{\mathcal{Q}}(4, -1^4)$.*

Proof Observe that

$$c_1 + c_2 + c_3 = c_4.$$

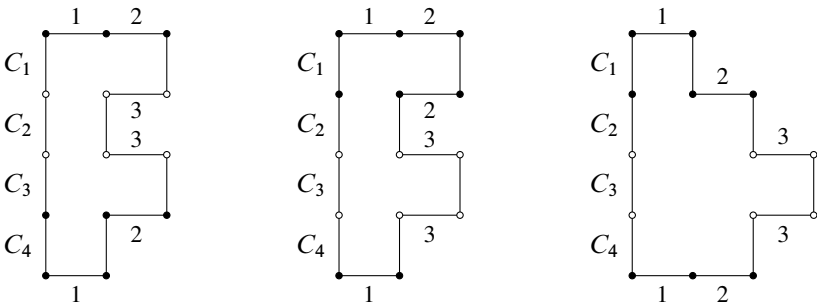

Figure 21: $\mathcal{H}^{\text{odd}}(2, 2)$, Cases 4.II.OA (left), 4.II.OB (center) and 4.II.OC (right)

By [Theorem 2.5](#), the horizontal cylinders of M fall into at least two equivalence classes. We claim that one of the simple cylinders is free. If C_1, C_2 and C_3 are \mathcal{M} -parallel, then the relation above implies that C_4 also belongs to this equivalence class, and we have a contradiction to the assumption that there are at least two equivalence classes. If one of C_1, C_2, C_3 is \mathcal{M} -parallel to C_4 , then we also have a unique equivalence class by [Lemma 2.11](#). Therefore, we can conclude that C_4 and one of the simple cylinders are free.

Let C_1 be the free simple cylinder. Collapse C_1 while keeping the other cylinders unchanged. This yields a surface $M' \in \tilde{\mathcal{Q}}(3, -1^3)$ by [Proposition 2.16](#) and [Theorem 1.4](#).

In particular, $M' \in \tilde{\mathcal{Q}}(3, -1^3)$; thus, there exists an involution τ' on M' that fixes C_4 and exchanges C_2 and C_3 . Note that C_1 degenerates to a horizontal saddle connection invariant by τ' . We claim that τ' can be extended to an involution τ on X that fixes C_1 and C_4 and exchanges C_2 and C_3 . To see this it suffices to show that there is an involution fixing C_1 . However, every simple cylinder can be realized as a parallelogram, which clearly admits an involution of order two given by rotation by π . Thus, τ' acts on M exactly as claimed, and we conclude that $M \in \tilde{\mathcal{Q}}(4, -1^4)$.

Since the boundary of \mathcal{M} contains $\tilde{\mathcal{Q}}(3, -1^3)$, by algebraicity we have $\dim_{\mathbb{C}}(\mathcal{M}) > \dim_{\mathbb{C}} \tilde{\mathcal{Q}}(3, -1^3) = 4$. Hence, $\dim_{\mathbb{C}}(\mathcal{M}) = 5$. For any $v \in T_M^{\mathbb{R}}\mathcal{M}$ and $\varepsilon \in \mathbb{R}$ small enough, the deformation $M_\varepsilon := M + \varepsilon v$ of M also has a cylinder decomposition in the horizontal direction with the same diagram. The arguments above then imply that $M_\varepsilon \in \tilde{\mathcal{Q}}(4, -1^4)$; thus, $T_M^{\mathbb{R}}\mathcal{M} \subset T_M^{\mathbb{R}}\tilde{\mathcal{Q}}(4, -1^4)$. Since $\dim_{\mathbb{C}} \mathcal{M} = \dim_{\mathbb{C}} \tilde{\mathcal{Q}}(4, -1^4)$, we have $T_M^{\mathbb{R}}\mathcal{M} = T_M^{\mathbb{R}}\tilde{\mathcal{Q}}(4, -1^4)$ and $\mathcal{M} = \tilde{\mathcal{Q}}(4, -1^4)$. □

6D2 Case 4.I.OB

Lemma 6.16 *Let M be a horizontally periodic translation surface in a rank two affine manifold \mathcal{M} . If M satisfies Case 4.I.OB, then $\mathcal{M} = \tilde{\mathcal{Q}}(4, -1^4)$.*

Proof Again, by [Theorem 2.5](#), we know that the horizontal cylinders of M must fall into at least two equivalence classes. If all of the cylinders are free, then $p(T_M^{\mathbb{R}}\mathcal{M})$ contains a Lagrangian subspace of dimension three. Therefore, we have at most three equivalence classes. We claim that there are exactly three equivalence classes of cylinders. Observe that we have

$$c_1 + c_3 = c_2 + c_4.$$

Therefore, if three of the cylinders belong to an equivalence class then all four cylinders are \mathcal{M} -parallel. Note that we cannot have $\mathcal{C}_1 = \{C_1, C_3\}$ and $\mathcal{C}_2 = \{C_2, C_4\}$ because

it would imply that there is one equivalence class by the homological relation among the core curves of cylinders.

Suppose that we have $\mathcal{C}_1 = \{C_1, C_2\}$ and $\mathcal{C}_2 = \{C_3, C_4\}$. Let us denote by $w(C_i)$ the circumference of C_i and α_i the element of $(T_M^{\mathbb{R}}\mathcal{M})^*$ defined by C_i . Recall that C_i and C_j are \mathcal{M} -parallel means precisely α_i and α_j are proportional (collinear). Thus, there exist $\lambda, \mu \in \mathbb{R}_{>0}$ such that $\alpha_1 = \lambda\alpha_2$ and $\alpha_3 = \mu\alpha_4$. Note that

$$\lambda = \frac{w(C_1)}{w(C_2)}, \quad \mu = \frac{w(C_3)}{w(C_4)}.$$

Thus we have

$$(1 - \lambda)\alpha_2 + (1 - \mu)\alpha_4 = 0 \in (T_M^{\mathbb{R}}\mathcal{M})^*.$$

But by assumption, α_2 and α_4 are not collinear, since C_2 and C_4 are not \mathcal{M} -parallel. Hence, we must have $\lambda = \mu = 1$. However, it is clear that $w(C_2) > w(C_1)$ and $w(C_3) > w(C_4)$, thus we get a contradiction. By the same argument, $\{C_1, C_4\}$ and $\{C_2, C_3\}$ are not equivalence classes. We can now conclude that the cylinders C_1, \dots, C_4 belong to three equivalence classes.

If C_2 is free, then we can collapse it to get a surface N in $\mathcal{H}(4)$ which must belong to $\tilde{\mathcal{Q}}(3, -1^3)$ (by Proposition 2.16 and Theorem 1.4). But a surface in $\tilde{\mathcal{Q}}(3, -1^3)$ cannot admit the same cylinder decomposition as N , therefore we have a contradiction, which means that C_2 is not free. The same arguments apply to C_4 .

Since M has three equivalence classes, and we know that neither of C_2 and C_4 is free, it follows that C_2 and C_4 must belong to the same equivalence class and both C_1 and C_3 are free. We can then collapse C_1 to get a surface N in $\mathcal{H}(4)$. Proposition 2.16 and Theorem 1.4 imply that this surface is contained in $\tilde{\mathcal{Q}}(3, -1^3)$. The Prym involution of N extends to an involution of M that fixes C_1 and C_3 and exchanges C_2 and C_4 . In particular, we have C_2 and C_4 are isometric, and $M \in \tilde{\mathcal{Q}}(4, -1^4)$.

Since the boundary of \mathcal{M} contains $\tilde{\mathcal{Q}}(3, -1^3)$, by algebraicity we have $\dim_{\mathbb{C}}(\mathcal{M}) > \dim_{\mathbb{C}} \tilde{\mathcal{Q}}(3, -1^3) = 4$. Hence, $\dim_{\mathbb{C}}(\mathcal{M}) = 5$. For any vector $v \in T_M^{\mathbb{R}}\mathcal{M}$, and $\varepsilon \in \mathbb{R}$ small enough, the deformation $M_\varepsilon := M + \varepsilon v$ also admits a cylinder decomposition in the horizontal direction with the same diagram. The arguments above show that $M_\varepsilon \in \tilde{\mathcal{Q}}(4, -1^4)$. Thus we have $T_M^{\mathbb{R}}\mathcal{M} \subset T_M^{\mathbb{R}}\tilde{\mathcal{Q}}(4, -1^4)$. But $\dim_{\mathbb{R}} T_M^{\mathbb{R}}\tilde{\mathcal{Q}}(4, -1^4) = 5$, thus we have $T_M^{\mathbb{R}}\mathcal{M} = T_M^{\mathbb{R}}\tilde{\mathcal{Q}}(4, -1^4) = 5$, which implies that $\mathcal{M} = \tilde{\mathcal{Q}}(4, -1^4)$. \square

6D3 Case 4.II.OC

Lemma 6.17 *If M is a horizontally periodic surface in \mathcal{M} , then M cannot admit a cylinder decomposition in Case 4.II.OC.*

Proof We assume that M admits a decomposition in Case 4.II.OC and will derive a contradiction. We first observe that c_2 and c_4 are homologous, hence C_2 and C_4 belong to the same equivalence class \mathcal{C} .

We will now show that C_3 is free. Suppose that $C_3 \in \mathcal{C}$; then C_1 is free since there are at least two equivalence classes. There exists a simple cylinder D in C_3 , which can be supposed to be vertical. Let $\mathcal{D} = \{D, D_1, \dots, D_k\}$ denote the equivalence class of D . Since C_2 is \mathcal{M} -parallel to C_3 , there must exist some vertical cylinders in \mathcal{D} that cross C_2 . Since D does not cross C_1 , neither do D_1, \dots, D_k , it follows that D_1, \dots, D_k do not fill C_2 . For each $i = 1, \dots, k$, let h'_i be the height of D_i , and let n_i (resp. m_i) be the number of intersections of the core curve of D_i with the core curve of C_2 (resp. the core curve of C_3). Clearly, $n_i \leq m_i$. Let ℓ_i denote the length of the horizontal saddle connection i , and let $\ell_4 = \ell_1 + \ell_2$. Note that the height of D is ℓ_3 . We have

$$P(C_2, \mathcal{D}) = \frac{(n_1 h'_1 + \dots + n_k h'_k) h_2}{\ell_4 h_2} = \frac{n_1 h'_1 + \dots + n_k h'_k}{\ell_4}$$

and

$$P(C_3, \mathcal{D}) = \frac{(m_1 h'_1 + \dots + m_k h'_k + \ell_3) h_3}{(\ell_4 + \ell_3) h_3} = \frac{m_1 h'_1 + \dots + m_k h'_k + \ell_3}{\ell_4 + \ell_3}.$$

Since the cylinders in \mathcal{D} do not fill C_2 , we have $P(C_2, \mathcal{D}) < 1$. Thus

$$P(C_2, \mathcal{D}) < \frac{n_1 h'_1 + \dots + n_k h'_k + \ell_3}{\ell_4 + \ell_3} \leq \frac{m_1 h'_1 + \dots + m_k h'_k + \ell_3}{\ell_4 + \ell_3} = P(C_3, \mathcal{D}).$$

We then get a contradiction, from which we conclude that C_3 cannot be \mathcal{M} -parallel to C_2 .

Next, let us assume that C_3 is \mathcal{M} -parallel to C_1 . Let D be the vertical simple cylinder in C_3 described above. Since C_1 is \mathcal{M} -parallel to C_3 , there must exist a vertical cylinder D' in the equivalence class of D that crosses C_1 . However, any vertical cylinder crossing C_1 must cross C_2 and C_4 . Hence, $P(D', \mathcal{C}) > 0$, but $P(D, \mathcal{C}) = 0$. The contradiction implies that C_3 is free.

Let us now assume that $C_1 \in \mathcal{C}$. Let 4 be the saddle connection between C_2 and C_3 , and let 5 be the saddle connection between C_3 and C_4 . Cut off C_3 from M and identify 4 and 5, we then get a surface $M_1 \in \mathcal{H}(2)$ which is the union of C_1, C_2, C_4 . By construction, M_1 is decomposed into two horizontal cylinders with distinguished simple closed geodesic c in the larger cylinder, which is the identification of 4 and 5 together with a marked point x on this geodesic that corresponds to the singularity in the boundary of C_3 .

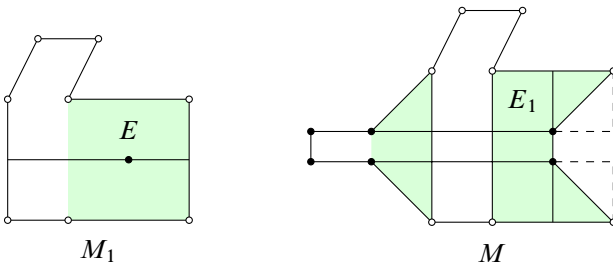

Figure 22: Decomposition in the vertical direction of M

Using $U = \left\{ \begin{pmatrix} 1 & t \\ 0 & 1 \end{pmatrix} \mid t \in \mathbb{R} \right\}$, we can assume that there is a vertical cylinder E contained in the larger cylinder of M_1 crossing the saddle connection 2. Since C_3 is free, we can freely twist it so that there is a vertical simple cylinder D contained in C_3 . Glue C_3 back to M_1 , we see that either E extends to a vertical cylinder in M crossing C_2 , C_3 and C_4 (if the marked point $x \notin E$), or E splits into two vertical cylinders (if $x \in E$); see Figure 22. In both cases let E_1 be one of the cylinders arising from E . Note that E_1 crosses C_2 and C_4 , but not C_1 . Since we assume that C_1 is \mathcal{M} -parallel to C_2 , there must exist a vertical cylinder E_2 in the equivalence class of E_1 that crosses C_1 . Let E_2 cross C_i n_i times. Some observations are in order. Since C_2 and C_4 are homologous, $n_2 = n_4$. The assumption that the simple cylinder $D \subset C_3$ is vertical implies $n_3 = n_2$ as well. This allows us to compute $P(E_1, \{C_3\}) = P(E_2, \{C_3\})$ to get

$$\frac{h_3}{h_2 + h_3 + h_4} = \frac{n_2 h_3}{n_1 h_1 + n_2 h_2 + n_2 h_3 + n_2 h_4}.$$

Hence, $n_1 = 0$, which implies the contradictory conclusion that no cylinder \mathcal{M} -parallel to E_1 passes through C_1 . We can then conclude that C_1 is free.

Recall that $h_i \zeta_i$ is the tangent vector (in $T_M^{\mathbb{R}} \mathcal{M}$) to the path which is the deformation of M by twisting C_i and fixing the rest of the surface. In particular ζ_i evaluates to zero on the core curves of all the cylinders (as the lengths of the core curves are unchanged along this path).

Observe that the core curves of C_1, C_2, C_3 span a Lagrangian in $H_1(M, \mathbb{Z})$. Since C_1 and C_3 are free, and C_2 and C_4 are \mathcal{M} -parallel, Theorem 2.3 implies that ζ_1, ζ_3 and $h_2 \zeta_2 + h_4 \zeta_4$ belong to $T_M^{\mathbb{R}} \mathcal{M}$. Since ζ_i vanishes on the core curves of C_1, \dots, C_4 , the cup product of $H^1(M, \mathbb{R})$ vanishes on the subspace $L \subset p(T_M^{\mathbb{R}} \mathcal{M})$ spanned by $p(\zeta_1), p(\zeta_3)$ and $p(h_2 \zeta_2 + h_4 \zeta_4)$. Since \mathcal{M} has rank two, we have $\dim_{\mathbb{R}} L \leq 2$.

Let $\zeta'_1 = p(\zeta_1)$, $\zeta'_2 = p(h_2 \zeta_2 + h_4 \zeta_4)$ and $\zeta'_3 = p(\zeta_3)$. Let s_i be an oriented saddle connection in C_i joining the zero in the bottom border to the zero in the top border of

C_i . Let $\gamma_1 = s_1$, $\gamma_2 = s_2 \cup s_4$ and $\gamma_3 = s_3$; then γ_1 , γ_2 and γ_3 represent elements of $H_1(M, \mathbb{Z})$. Note that we have

$$\zeta'_i(\gamma_j) = 0 \quad \text{if } i \neq j \quad \text{and} \quad \zeta'_i(\gamma_i) \neq 0,$$

which implies that ζ'_1 , ζ'_2 and ζ'_3 are independent, hence $\dim_{\mathbb{R}} L = 3$. We then have a contradiction, which means that Case 4.II.OC cannot occur. □

6D4 Case 4.II.OA

Lemma 6.18 *Let M be a horizontally periodic translation surface in a rank two affine manifold $\mathcal{M} \subset \mathcal{H}^{\text{odd}}(2, 2)$. If M satisfies Case 4.II.OA, then there exists $M' \in \mathcal{M}$ horizontally periodic satisfying Case 4.II.OB.*

Proof Clearly c_1 and c_3 are homologous, therefore $\alpha_1 = \alpha_3$ (α_i is the element of $(T_M^{\mathbb{R}} \mathcal{M})^*$ defined by c_i). Let \mathcal{C} denote the equivalence class of C_1 . Since we have at least two equivalence classes, at least one of C_2 or C_4 does not belong to \mathcal{C} . Without loss of generality, let us assume that $C_4 \notin \mathcal{C}$. Set $V := T_M^{\mathbb{R}} \mathcal{M} \subset H^1(M, \Sigma, \mathbb{R})$. If C_2 and C_4 are both free, then by similar arguments to the proof of Case 4.II.OC, we see that the projection of the family $\{h_1 \zeta_1 + h_3 \zeta_3, \zeta_2, \zeta_4\}$ spans a Lagrangian subspace of dimension three in $p(V)$, which is impossible. Therefore, we only need to consider two cases:

(a) ($C_2 \in \mathcal{C}$ and C_4 is free) In this case we have $\ker \alpha_1 = \ker \alpha_2 = \ker \alpha_3 \neq \ker \alpha_4 \subset T_M^{\mathbb{R}} \mathcal{M}$. Let $v \in \ker \alpha_1 \setminus \ker \alpha_4$ be a vector such that $\alpha_1(v) = 0$ and $\alpha_4(v) = 1$. Consider the surface $M' := M + \iota \varepsilon v$, with $\varepsilon \in \mathbb{R}$ small enough. We will identify surfaces in a neighborhood of M with elements of $H^1(M, \Sigma; \mathbb{R})$ via the period mapping. With this identification, if s is a saddle connection or a core curve of a cylinder on M , by $s(M)$ and $s(M')$ we will mean the periods of s in M and M' , respectively. Note that the cylinders C_i persist under all small deformations of M in the sense that closed curves are sent to closed curves even if they do not remain parallel (or horizontal). We have

$$c_j(M') = c_j(M) \in \mathbb{R}, \quad j = 1, 2, 3, \quad \text{since } v(c_j) = 0,$$

and

$$c_4(M') = c_4(M) + \iota \varepsilon \notin \mathbb{R},$$

which implies that c_1 , c_2 and c_3 are horizontal in M' , but c_4 is not. It follows that the lower boundary of C_3 and the upper boundary of C_1 become broken lines in M' (see Figure 23). Let C'_i denote the cylinder in M' with core curve c_i . Note also that the cylinders C'_1 , C'_2 , C'_3 and C'_4 do not fill M' . The complement of $C'_1 \cup C'_2 \cup C'_3$ is a slit

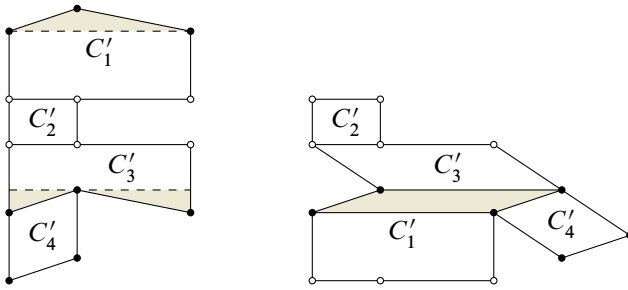

Figure 23: Deformation of a surface in Case 4.II.OA to Case 4.II.OC

torus that properly contains C'_4 . Since \mathcal{M} is defined over \mathbb{Q} , we can choose M and ε so that M' is a square-tiled surface, in particular M' admits a cylinder decomposition in the horizontal direction, which means that the slit torus is horizontally periodic. It is not difficult to check that the cylinder decomposition of M' belongs to Case 4.II.OC. Hence, by Lemma 6.17 this case does not occur.

(b) (C_2 and C_4 are \mathcal{M} -parallel) By assumption, there exists $\mu \in \mathbb{R}_{>0}$ such that $\alpha_2 = \mu\alpha_4$. Since $C_4 \notin \mathcal{C}$, there exists a vector $v \in V$ such that $\alpha_1(v) = 0$ and $\alpha_4(v) = 1$. Note that in this case we have $\alpha_2(v) = \mu\alpha_4(v) \neq 0$. Consider the deformation $M' = M + t\varepsilon v$, with $\varepsilon \in \mathbb{R}$ small enough. Let C'_i be the cylinders in M' corresponding to C_i . Using the same argument as above, we see that C'_1 and C'_3 are horizontal, but C'_2 and C'_4 are not. Note that in this case C'_1 and C'_3 are simple cylinders, and the complement of $C'_1 \cup C'_3$ is the disjoint union of two slit tori containing C'_2 and C'_4 (see Figure 24). We can choose M and ε so that M' is a square-tiled surface. Hence, M' is horizontally periodic. It is not difficult to check that the diagram of the cylinder decomposition of M' belongs to Case 4.II.OB. The lemma is then proved. \square

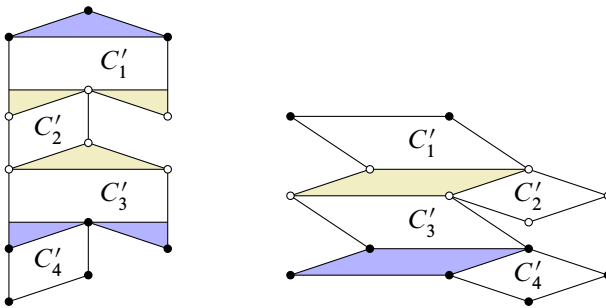

Figure 24: Deformation of a surface in Case 4.II.OA to Case 4.II.OB

6D5 Case 4.II.OB

Lemma 6.19 *Let M be a horizontally periodic translation surface in a rank two affine manifold $\mathcal{M} \subset \mathcal{H}^{\text{odd}}(2, 2)$. If M satisfies Case 4.II.OB, then C_1 and C_3 are isometric, and either*

- (a) $\mathcal{M} = \tilde{\mathcal{Q}}(4, -1^4)$, or
- (b) $\mathcal{M} = \tilde{\mathcal{H}}_{(2,2)}^{\text{odd}}(2) \subset \tilde{\mathcal{Q}}(4, -1^4)$, in which case C_2 and C_4 are isometric.

In particular, $\tilde{\mathcal{H}}_{(2,2)}^{\text{odd}}(2)$ is connected.

Proof We first notice that c_2 and c_4 are homologous, therefore C_2 and C_4 are \mathcal{M} -parallel; let us denote by \mathcal{C} their equivalence class.

Claim 1 *Neither C_1 nor C_3 belongs to \mathcal{C} .*

Proof Assume that $C_1 \in \mathcal{C}$, then C_3 must be free since we have at least two equivalence classes. There exists a transverse simple cylinder D contained in C_1 , which can be made vertical by using $\left\{ \begin{pmatrix} 1 & t \\ 0 & 1 \end{pmatrix} \mid t \in \mathbb{R} \right\}$. By assumption, there must exist another vertical cylinder D' in the equivalence class of D that crosses C_2 . But any vertical cylinder crossing C_2 must cross C_3 , hence $P(D', \{C_3\}) > 0$ while $P(D, \{C_3\}) = 0$, and we have a contradiction. The same arguments apply for C_3 . □

Claim 2 *C_1 and C_3 are \mathcal{M} -parallel.*

Proof Indeed, if this is not the case then both C_1 and C_3 are free by Claim 1. It follows that the projection of $\{\zeta_1, \zeta_3, h_2\zeta_2 + h_4\zeta_4\}$ in absolute cohomology spans a Lagrangian subspace of $p(T_M^{\mathbb{R}}\mathcal{M})$ of dimension three, which is impossible. □

Claim 3 *C_1 and C_3 are isometric.*

Proof Observe that the closures of C_1 and C_3 are two slit tori, which will be denoted by T_1 and T_3 , respectively. Let D_1 be any simple cylinder in T_1 that does not meet the slit. Since C_3 is \mathcal{M} -parallel to C_1 by Claim 2, there must exist a cylinder D_3 that is \mathcal{M} -parallel to D_1 and crosses C_3 . Note that $P(D_1, \mathcal{C}) = 0$, hence $P(D_3, \mathcal{C}) = 0$, which implies that D_3 is a simple cylinder contained in T_3 . Moreover, from [Proposition 2.6](#) we have

$$P(D_1, \{C_1, C_3\}) = P(D_3, \{C_1, C_3\}) \implies P(D_1, \{C_1\}) = P(D_3, \{C_3\}).$$

The claim then follows from [\[2, Lemma 8.1\]](#). □

Since C_1 and C_3 are isometric, we see that $M := (X, \omega)$ admits an involution τ that exchanges C_1 and C_3 , fixes C_2 and C_4 , and satisfies $\tau^*\omega = -\omega$ (that is, the derivative of τ in local charts defined by the flat metric structure is given by $-\text{Id}$). Observe that τ exchanges the singularities of M and has four fixed points, two in C_2 and two in C_4 . It is now a routine to check that M is a double cover of a quadratic differential in $\mathcal{Q}(4, -1^4)$. We can now conclude that $M \in \tilde{\mathcal{Q}}(4, -1^4)$.

Claim 4 $\mathcal{M} \subseteq \tilde{\mathcal{Q}}(4, -1^4)$.

Proof Let v be a vector in $V := T_M^{\mathbb{R}}\mathcal{M}$. For $\varepsilon \in \mathbb{R}$ small enough, the deformation $M' := M + \varepsilon v$ of M also admits a cylinder decomposition in the horizontal direction with the same diagram. The argument above implies that $M' \in \tilde{\mathcal{Q}}(4, -1^4)$. Thus, we have $T_M^{\mathbb{R}}\mathcal{M} \subseteq T_M^{\mathbb{R}}\tilde{\mathcal{Q}}(4, -1^4)$ and $\mathcal{M} \subseteq \tilde{\mathcal{Q}}(4, -1^4)$. \square

Recall that ζ_i is the vector in $H^1(X, \Sigma, \mathbb{R})$ tangent to the deformations of M by twisting C_i alone. Note that deformations of M by twisting and stretching simultaneously C_1 and C_3 , or C_2 and C_4 , remain in \mathcal{M} . Since C_1 and C_2 are isometric, twisting simultaneously C_1 and C_3 gives deformations along the line defined by the vector $\zeta_1 + \zeta_3$. On the other hand, twisting simultaneously C_2 and C_4 gives deformations along the line defined by the vector $h_2\zeta_2 + h_4\zeta_4$.

Claim 5 If ζ_2 or ζ_4 belongs to $T_M^{\mathbb{R}}\mathcal{M}$, then $\mathcal{M} = \tilde{\mathcal{Q}}(4, -1^4)$.

Proof Set $V := T_M^{\mathbb{R}}\mathcal{M} \subset H^1(M, \Sigma; \mathbb{R})$. By the observation above, we already have $h_2\zeta_2 + h_4\zeta_4 \in V$. If ζ_2 or ζ_4 belongs to V , then both of them belong to V . But if ζ_2 belongs to $T_M^{\mathbb{R}}\mathcal{M}$ then we can freely stretch and shear C_2 while keeping the rest of the surface unchanged to obtain other surfaces in \mathcal{M} (see [18, Lemma 2.3]). It follows that we can collapse C_2 to degenerate a saddle connection in C_2 to a point and obtain a surface $N \in \bar{\mathcal{M}} \cap \mathcal{H}(4)$. From Proposition 2.16 and Theorem 1.4, we know that $\bar{\mathcal{M}} \cap \mathcal{H}(4)$ contains $\tilde{\mathcal{Q}}(3, -1^3)$. Thus $\dim_{\mathbb{C}} \mathcal{M} \geq \dim_{\mathbb{C}} \tilde{\mathcal{Q}}(3, -1^3) + 1 = 5$. On the other hand, we know that $\mathcal{M} \subset \tilde{\mathcal{Q}}(4, -1^4)$ and $\dim_{\mathbb{C}} \tilde{\mathcal{Q}}(4, -1^4) = 5$. Therefore, we can conclude that $\dim_{\mathbb{C}} \mathcal{M} = 5$ and $\mathcal{M} = \tilde{\mathcal{Q}}(4, -1^4)$. \square

Recall that we use the notations $h(C_i)$, $w(C_i)$ and $t(C_i)$ to denote the height, circumference and twist of C_i . We can normalize so that $h(C_2) = w(C_2) = 1$ and $t(C_2) = 0$. Note that we also have $w(C_4) = 1$. Set $h = h(C_4)$ and $x := t(C_4)$.

Claim 6 If $x \not\equiv 0 \pmod{\mathbb{Z}}$, then $\mathcal{M} = \tilde{\mathcal{Q}}(4, -1^4)$.

Proof Without loss of generality, let $x \in (0, 1)$. Collapse the cylinders $\{C_2, C_4\}$ to get a translation surface in $\mathcal{H}(4)$. By Proposition 2.16, the resulting translation surface lies in a rank two affine manifold, which must be $\tilde{\mathcal{Q}}(3, -1^3)$. Hence, $\tilde{\mathcal{Q}}(3, -1^3)$ lies in the boundary of \mathcal{M} . By algebraicity, this implies that $\dim_{\mathbb{C}}(\mathcal{M}) = 5$, so Claim 4 implies that \mathcal{M} is a full-dimensional subset of $\tilde{\mathcal{Q}}(4, -1^4)$. But it is well known that $\tilde{\mathcal{Q}}(4, -1^4)$ is connected (see [11, Theorem 1.2]). Therefore, we must have $\mathcal{M} = \tilde{\mathcal{Q}}(4, -1^4)$. \square

Claim 7 If $\mathcal{M} \neq \tilde{\mathcal{Q}}(4, -1^4)$, then C_2 and C_4 are isometric and $\mathcal{M} \subset \tilde{\mathcal{H}}_{(2,2)}^{\text{odd}}(2)$.

Proof By Claim 6 we must have $t(C_4) = 0$. Let \hat{C}_2 and \hat{C}_4 denote the cylinders obtained by applying the matrix $\begin{pmatrix} 1 & 0 \\ 0 & 1 \end{pmatrix}$ to C_2 and C_4 , respectively. We have $t(\hat{C}_2) = t(C_2) = 0$ and $t(\hat{C}_4) = h$. By Claim 6, we must have $h \equiv 0 \pmod{\mathbb{Z}}$, which implies that $h \in \mathbb{N}$, or equivalently $h(C_4)/h(C_1) \in \mathbb{N}$. Since the roles of C_2 and C_4 can be exchanged, we can conclude that $h(C_1) = h(C_4)$, and it follows that C_2 and C_4 are isometric.

Observe that we then have an automorphism $f: M \rightarrow M$ of order two that exchanges C_1 with C_3 and C_2 with C_4 , and satisfies the following condition: the derivative of f in local charts defined by the flat metric structure is given by Id. Identify M with a pair (X, ω) ; we have $f^*\omega = \omega$. Observe that f has no fixed points on X .

Let $Y := X/\langle f \rangle$, and $\pi: X \rightarrow Y$ be the natural projection. Since f has order two and no fixed points, π is an unramified double cover, which implies that Y is a surface of genus two. Since $f^*\omega = \omega$, there exists a holomorphic 1-form η on Y such that $\omega = \pi^*\eta$. By definition ω has two zeros of order two, thus η must have a single zero of order two, which means that $(Y, \eta) \in \mathcal{H}(2)$ hence $M = (X, \omega) \in \tilde{\mathcal{H}}_{(2,2)}^{\text{odd}}(2)$.

Now, for any vector $v \in T_M^{\mathbb{R}}\mathcal{M}$, and $\varepsilon \in \mathbb{R}$ small enough, the surface $M_\varepsilon := M + \varepsilon v$ also belongs to \mathcal{M} and admits a cylinder decomposition in the horizontal direction with the same diagram as M . The previous claims imply that $M_\varepsilon \in \tilde{\mathcal{H}}_{(2,2)}^{\text{odd}}(2)$. Therefore we have $T_M^{\mathbb{R}}\mathcal{M} \subset T_M^{\mathbb{R}}\tilde{\mathcal{H}}_{(2,2)}^{\text{odd}}(2)$ and $\mathcal{M} \subset \tilde{\mathcal{H}}_{(2,2)}^{\text{odd}}(2)$. \square

Claim 8 $\tilde{\mathcal{H}}_{(2,2)}^{\text{odd}}(2)$ is connected. If $\mathcal{M} \not\subset \tilde{\mathcal{Q}}(4, -1^4)$, then $\mathcal{M} = \tilde{\mathcal{H}}_{(2,2)}^{\text{odd}}(2)$.

Proof By definition, each component of $\tilde{\mathcal{H}}_{(2,2)}^{\text{odd}}(2)$ is a proper rank two affine submanifold of dimension four in $\tilde{\mathcal{Q}}(4, -1^4)$. From Lemmas 6.15, 6.16, 6.17 and 6.18, we know that this affine submanifold contains a surface horizontally periodic satisfying Case 4.II.OB. Claim 3 and Claim 7 then imply that C_1 and C_2 are isometric to C_3 and C_4 , respectively. Observe that if C_1 is isometric to C_3 and C_2 is isometric to C_4 , then $M \in \tilde{\mathcal{H}}_{(2,2)}^{\text{odd}}(2)$. Clearly the set of horizontally periodic surfaces satisfying

Case 4.II.OB with this additional condition is connected. Thus we can conclude that $\tilde{\mathcal{H}}_{(2,2)}^{\text{odd}}(2)$ is connected.

Suppose that $\mathcal{M} \subsetneq \tilde{\mathcal{Q}}(4, -1^4)$ is a rank two affine submanifold. Since $\tilde{\mathcal{Q}}(4, -1^4)$ is connected, we must have $\dim_{\mathbb{C}} \mathcal{M} < \dim_{\mathbb{C}} \tilde{\mathcal{Q}}(4, -1^4) = 5$. Since \mathcal{M} has rank two, we must have $\dim_{\mathbb{C}} \mathcal{M} \geq 4$, from which we conclude that $\dim_{\mathbb{C}} \mathcal{M} = 4$.

From Claim 7, we know that $\mathcal{M} \subset \tilde{\mathcal{H}}_{(2,2)}^{\text{odd}}(2)$. Since $\dim_{\mathbb{C}} \mathcal{M} = \dim_{\mathbb{C}} \tilde{\mathcal{H}}_{(2,2)}^{\text{odd}}(2) = 4$, \mathcal{M} must be a component of $\tilde{\mathcal{H}}_{(2,2)}^{\text{odd}}(2)$. But $\tilde{\mathcal{H}}_{(2,2)}^{\text{odd}}(2)$ is connected, therefore we have $\mathcal{M} = \tilde{\mathcal{H}}_{(2,2)}^{\text{odd}}(2)$. The claim is then proved \square

The proof of the lemma is now complete. \square

Appendix:

Dual graphs and 4–cylinder diagrams in $\mathcal{H}(m, n)$, $m + n = 4$

In this section we give the complete list of 4–cylinder diagrams for surfaces in genus three having two singularities. To obtain this list our approach is to use the dual graphs. In this situation, the dual graphs have exactly four vertices and six edges. We classify them by the valencies at their vertices (the total valency is 12). Given an integral vector (n_1, \dots, n_4) such that $n_1 \leq \dots \leq n_4$ and $n_1 + \dots + n_4 = 12$, we look for undirected graphs satisfying this condition on the valencies. For each of the graphs, we then look for orientations of the edges such that no forbidden configuration occurs (see Section 2B). Finally, we choose for each vertex a cyclic ordering on the set of incoming edges, and a cyclic ordering on the set of outgoing edges. It turns out this procedure can be carried out “by hand” for the case $\mathcal{H}(m, n)$, $m + n = 4$, as all except one admissible undirected graph provide us with a unique corresponding cylinder diagram (that is, there is only at most one way to choose the orientations of the edges such that there is no forbidden configuration). As a result, we found 11 4–cylinder diagrams. The exercise to determine which component the diagram belongs to is left to the reader.

Proposition A.1 *Let M be a horizontally periodic surface with four horizontal cylinders in a stratum $\mathcal{H}(m, n)$, $m + n = 4$. Then the cylinder diagram of M is given in Figures 25, 26, 27 and 28. In all of these figures, the cylinder C_i corresponds to the vertex v_i of the dual graph for $i = 1, \dots, 4$.*

Proof Let C_1, \dots, C_4 be the horizontal cylinders of M . Let \mathcal{D} denote the dual graph of the cylinder decomposition of M ; the vertices of \mathcal{D} are v_1, \dots, v_4 , where v_i corresponds to C_i . Let n_i be the valency of v_i . We always choose the numbering so

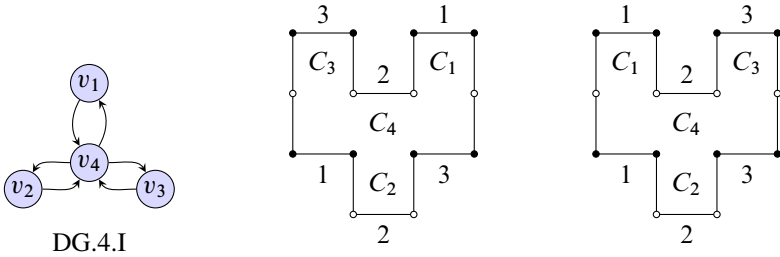

Figure 25: Admissible dual graphs for the valency vector $(2, 2, 2, 6)$

that $n_1 \leq n_2 \leq n_3 \leq n_4$. Recall that we must have $n_1 + n_2 + n_3 + n_4 = 12$, therefore $n_1 \leq 3 \leq n_4$.

We first claim that $n_1 = 2$. Clearly $n_1 \neq 1$. If $n_1 = 3$, then $n_1 = n_2 = n_3 = n_4 = 3$, which means that all of the cylinders C_1, \dots, C_4 are semisimple. For any i , let w_i be the circumference of C_i . Since C_i is semisimple, without loss of generality assume that its bottom side v consists of a single saddle connection σ_i . Since σ_i must be contained in the top of a cylinder C_j , and clearly the top of C_j must contain another saddle connection, we derive $w_i < w_j$. It follows that for all $i \in \{1, \dots, 4\}$, there exists $j \in \{1, \dots, 4\}$ such that $w_i < w_j$, and we get a contradiction.

From the previous claim, we have

$$\vec{n} := (n_1, \dots, n_4) \in \{(2, 2, 2, 6), (2, 2, 3, 5), (2, 2, 4, 4), (2, 3, 3, 4)\}.$$

Case $\vec{n} = (2, 2, 2, 6)$ Since two simple cylinders cannot be adjacent, the three vertices with valency equal to two must be attached to v_4 . Thus, we have the dual graph DG.4.I, and the cylinder diagram of M is given by one of the two diagrams in Figure 25.

Case $\vec{n} = (2, 2, 3, 5)$ First suppose that each of v_1 and v_2 is attached to a single vertex. If both v_1 and v_2 are attached to the same vertex, which must be v_4 , then we

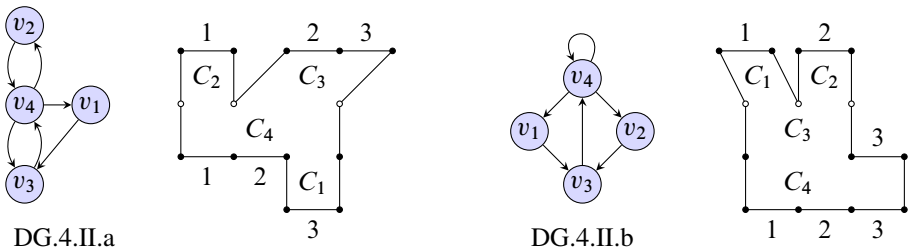

Figure 26: Admissible dual graphs for the valency vector $(2, 2, 3, 5)$

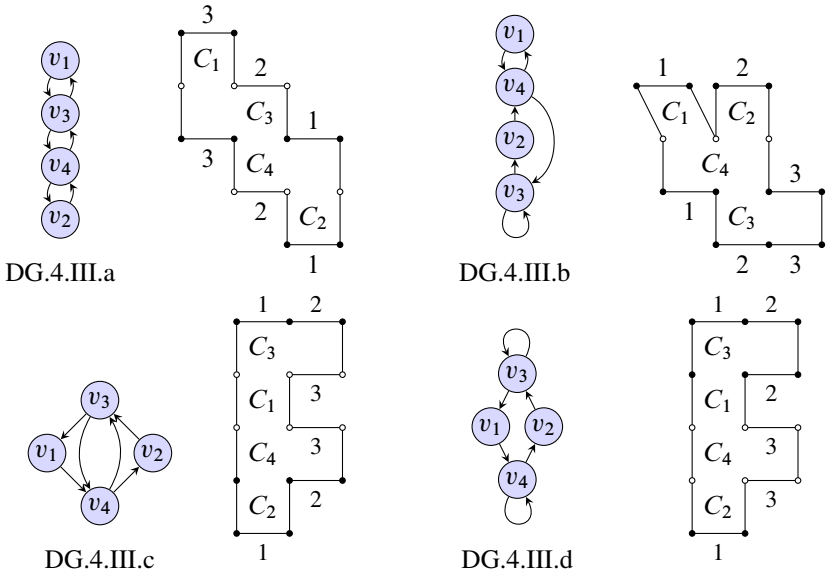

Figure 27: Admissible dual graphs for the valency vector $(2, 2, 4, 4)$

would have a forbidden configuration at v_3 . If v_1 or v_2 is attached to v_3 , then we also have a forbidden configuration. Thus, at least one of v_1 or v_2 , say v_1 , is connected to both v_3 and v_4 .

If v_2 is attached to a single vertex, then this vertex must be v_4 , and in this case v_4 and v_3 must be connected by two edges; we then get the dual graph DG.4.II.a. If v_2 is also connected to both v_3 and v_4 , then there must be an edge joining v_3 to v_4 and a loop at v_4 ; thus we get the dual graph DG.4.II.b.

Case $\vec{n} = (2, 2, 4, 4)$ In the case that each of v_1 and v_2 is attached (by two edges) to a single vertex, we can assume that v_1 is attached to v_3 , and v_2 to v_4 . It follows that v_3 and v_4 must be connected by two edges, and we get the dual graph DG.4.III.a.

If v_1 is connected to both v_3 and v_4 , and v_2 is attached to only one vertex, say v_4 , then there must be an edge between v_3 and v_4 and a loop at v_3 ; thus, we get the dual graph DG.4.III.b.

If each of v_1 and v_2 are connected to both v_3 and v_4 , then we have two cases: either there are two edges between v_3 and v_4 , in which case we get the dual graph DG.4.III.c, or there is a loop at v_3 and a loop at v_4 , which gives the dual graph DG.4.III.d.

Case $\vec{n} = (2, 3, 3, 4)$ If v_1 is attached to a single vertex, this vertex must be v_4 . If v_4 were connected to only one of v_2 and v_3 , then we would have the forbidden

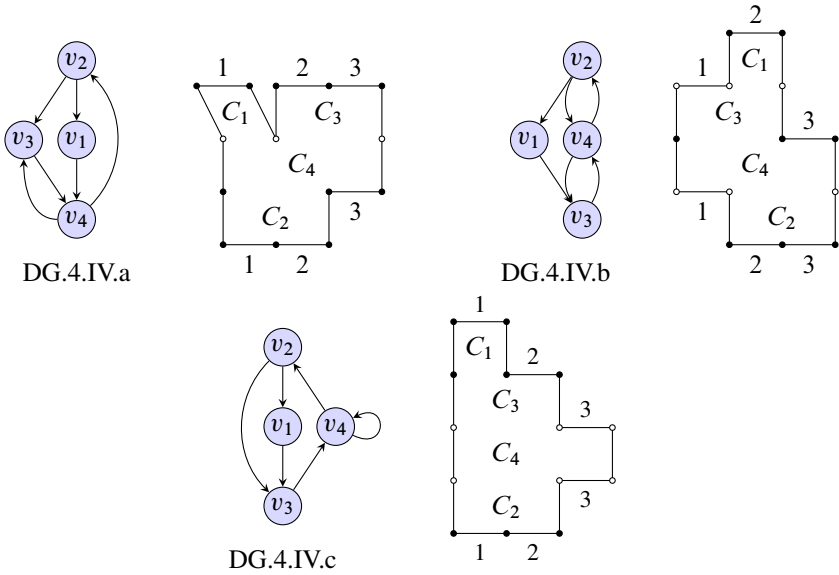

Figure 28: Admissible dual graphs for the valency vector $(2, 3, 3, 4)$

configuration at v_2 or v_3 , thus there must be an edge between v_4 and v_2 and an edge between v_4 and v_3 . It follows that v_2 and v_3 are connected by two edges, and there is a unique dual graph satisfying this case. But, by case-by-case inspection, it turns out that for any choice of orientation for the edges we always have a forbidden configuration, therefore this case is excluded.

Now assume that v_1 is connected to two other vertices.

- If v_1 is connected to v_2 and v_3 , then we have two cases: either v_2 and v_3 are not connected, which means that they are each connected to v_4 by two edges and we get the dual graph DG.4.IV.b. Otherwise, v_2 and v_3 are connected by an edge, which implies that v_4 is connected to v_2 and v_3 by one edge and there is a loop at v_4 , which yields the dual graph DG.4.IV.c.
- If v_1 is connected to v_4 and a vertex with valency three, says v_2 , then we also have two cases: either v_2 is connected to v_4 by one edge, which implies that v_3 is connected to v_2 by one edge and to v_4 by two edges, and we get the dual graph DG.4.IV.a, or v_2 is not connected to v_4 , which implies that v_3 is connected to v_2 by two edges, to v_4 by one edge, and there is a loop at v_4 . In the latter case, an inspection of the orientations of the edges shows that we always have a forbidden configuration. Hence, there is no corresponding cylinder diagram for this case.

It is not difficult to get the complete list of cylinder diagrams from the list of admissible undirected dual graphs. The details are left for the reader. \square

References

- [1] **D Aulicino**, *Affine invariant submanifolds with completely degenerate Kontsevich–Zorich spectrum*, Ergodic Theory Dynam. Systems (2016) online publication July
- [2] **D Aulicino, D-M Nguyen, A Wright**, *Classification of higher rank orbit closures in $\mathcal{H}^{\text{odd}}(4)$* , J. Eur. Math. Soc. (JEMS) 18 (2016) 1855–1872 [MR3518480](#)
- [3] **A Avila, A Eskin, M Moeller**, *Symplectic and isometric $\text{SL}(2, \mathbb{R})$ -invariant subbundles of the Hodge bundle*, preprint (2012) [arXiv:1209.2854v1](#)
- [4] **A Eskin, H Masur, A Zorich**, *Moduli spaces of abelian differentials: the principal boundary, counting problems, and the Siegel–Veech constants*, Publ. Math. Inst. Hautes Études Sci. 97 (2003) 61–179 [MR2010740](#)
- [5] **A Eskin, M Mirzakhani**, *Invariant and stationary measures for the $\text{SL}(2, \mathbb{R})$ action on moduli space*, preprint (2013) [arXiv:1302.3320](#)
- [6] **A Eskin, M Mirzakhani, A Mohammadi**, *Isolation, equidistribution, and orbit closures for the $\text{SL}(2, \mathbb{R})$ action on moduli space*, Ann. of Math. 182 (2015) 673–721 [MR3418528](#)
- [7] **S Filip**, *Semisimplicity and rigidity of the Kontsevich–Zorich cocycle*, Invent. Math. 205 (2016) 617–670 [MR3539923](#)
- [8] **S Filip**, *Splitting mixed Hodge structures over affine invariant manifolds*, Ann. of Math. 183 (2016) 681–713 [MR3450485](#)
- [9] **M Kontsevich**, *Intersection theory on the moduli space of curves and the matrix Airy function*, Comm. Math. Phys. 147 (1992) 1–23 [MR1171758](#)
- [10] **M Kontsevich, A Zorich**, *Connected components of the moduli spaces of abelian differentials with prescribed singularities*, Invent. Math. 153 (2003) 631–678 [MR2000471](#)
- [11] **E Lanneau**, *Connected components of the strata of the moduli spaces of quadratic differentials*, Ann. Sci. Éc. Norm. Supér. 41 (2008) 1–56 [MR2423309](#)
- [12] **C T McMullen**, *Dynamics of $\text{SL}_2(\mathbb{R})$ over moduli space in genus two*, Ann. of Math. 165 (2007) 397–456 [MR2299738](#)
- [13] **M Mirzakhani, A Wright**, *The boundary of an affine invariant submanifold*, preprint (2015) [arXiv:1508.01446](#)
- [14] **D-M Nguyen**, *On the topology of $\mathcal{H}(2)$* , Groups Geom. Dyn. 8 (2014) 513–551 [MR3231227](#)
- [15] **D-M Nguyen, A Wright**, *Non-Veech surfaces in $\mathcal{H}^{\text{hyp}}(4)$ are generic*, Geom. Funct. Anal. 24 (2014) 1316–1335 [MR3248487](#)

- [16] **J Smillie, B Weiss**, *Minimal sets for flows on moduli space*, Israel J. Math. 142 (2004) 249–260 [MR2085718](#)
- [17] **A Wright**, *The field of definition of affine invariant submanifolds of the moduli space of abelian differentials*, Geom. Topol. 18 (2014) 1323–1341 [MR3254934](#)
- [18] **A Wright**, *Cylinder deformations in orbit closures of translation surfaces*, Geom. Topol. 19 (2015) 413–438 [MR3318755](#)

Department of Mathematics, University of Chicago
5734 University Avenue, Chicago, IL 60637, United States

University of Bordeaux, Bat. A33, IMB, CNRS UMR 5251
351, cours de la Libération, F-33405 Talence, France

auricino@math.uchicago.edu, duc-manh.nguyen@math.u-bordeaux.fr

Proposed: Benson Farb

Received: 15 March 2015

Seconded: Danny Calegari, Martin Bridson

Revised: 28 July 2015