

SEASONAL PERIODICITY IN THEORETICAL POPULATION ECOLOGY

J. G. SKELLAM

NATURAL ENVIRONMENT RESEARCH COUNCIL,
THE NATURE CONSERVANCY, LONDON

1. Introduction

1.1. *Biological populations and mathematics.* Biological populations, involving one or more species of animal or plant or disease producing organism, have been a source of inspiration to the mathematically minded for more than two centuries [4]. Today there can be little doubt that the study of mathematical population models helps to deepen our understanding of real population processes and to render intelligible many phenomena which would otherwise remain obscure (for example, (1) the stability of the age structure in a freely growing population, (2) the occurrence of distributions akin to the logarithmic in studies on the diversity of communities).

Even so, these advances have had much less impact on the consumer, the conventional ecologist, than they merit. The reasons are threefold:

(i) very few ecologists understand sophisticated mathematics couched in modern terms;

(ii) the mathematician's preoccupation with rigor often appears inconsistent with his somewhat superficial attitude to biological realities, often apparently dismissed as unwelcome complications best forgotten;

(iii) mathematical systems, because of their abstract beauty and austere elegance contrast sharply with the color and richness of animate nature.

Nevertheless, the biologist and the mathematician, despite their different attitudes, are both right, each in his own way. It is only proper for the mathematician to exercise a high degree of thoroughness in deducing the properties of the mathematical system *from which he starts*, and it is equally proper for the biologist to question the applicability of a model with just the same thoroughness, even to the point of asserting that no mathematical system can receive his *unqualified* approval unless it embodies the logical structure of a real system exactly. It is indeed paradoxical that when biologists adopt the unbending logic characteristic of mathematics and proceed to demand of applied mathematicians that they justify their formulations, the gulf between the two disciplines immediately widens.

The resolution of this paradox is perhaps a matter more appropriate to the field of scientific epistemology, but the causes underlying this regrettable dichotomy are clear. They arise in part from differences in the historical develop-

ment of these two great disciplines, in part from the perpetuation of traditional attitudes to education, but primarily from a widespread failure to recognize the critical importance of a small neglected area of intellectual activity, which for want of a generally accepted label may be called "theoretics." To this both natural science and applied mathematics are methodologically subordinate.

With the mathematical model as its central concept, theoretics is both an art and a science. The art of theoretics consists in the construction of models which are both mathematically tractable and scientifically meaningful. The applicability of the model depends on the extent to which the theoretician succeeds in abstracting the essential operative factors from the real situation which he strives to simulate. But it is not enough just to rely on his insight and judgment. The time has come when there is a clear need for the systematic investigation of models with a view to discovering which features are of crucial importance and which are not, and to determine the extent and under what circumstances various levels of abstraction and simplification may be safely employed. To achieve this end theoretics must adopt both the comparative and the experimental approach. Admittedly much is already well known or appears obvious or elementary to those who are experienced in the construction of mathematical models, but very little of this valuable knowledge has been presented in an orderly way or given sufficient prominence in the literature.

1.2. *Early population models.* At first population models, quite understandably, were extremely simple, for example,

$$(1.1) \quad N_{t+1} = cN_t$$

(Linnaeus [16] with $c = 2$),

$$(1.2) \quad \frac{dN}{dt} \propto N(K - N)$$

(Verhulst [25]). In these examples it will be observed: (i) that all individuals are treated *as if* they were alike regardless of their condition; (ii) that no account is taken of the operation of chance factors; and (iii) that time, whether discrete or continuous, is regarded as homogenous.

The first defect has been largely overcome by classifying the individuals into more homogeneous groups by sex and age. As a result a number of valuable theorems have emerged which relate population growth and age structure to fecundity and survival [21]. It is interesting, however, to note that the more elaborate system of Lotka still behaves like its simple Malthusian prototype, at least asymptotically.

The second defect has also been surmounted to some extent by the formulation of population models in stochastic terms. As a result many valuable theorems on ergodicity and extinction have appeared [6], [7], [12]. Even so, it is interesting to note that the "growth in mean" of a stochastic population system is often identical with the growth curve of its deterministic analogue, and is rarely appreciably different unless the population tends to remain at a low level or is followed through an excessively long interval of time.

With these two defects largely overcome it has become possible to construct mathematical schemata which do appear to mimic real biological systems and some even attempt to simulate special or unusual structural features (see [20], where egg cannibalism in laboratory populations of *Tribolium* creates a serious complication).

The third apparent defect mentioned earlier (the assumption that the vital coefficients are independent of time) has received little attention from mathematical ecologists. This is indeed amazing because the most striking features of life on this planet are directly attributable to the diurnal rotation of the earth on its inclined axis and its annual journey round the sun. The behavior and reproductive cycles of living organisms are closely adapted to the regular alternation of summer and winter or of wet season and dry season.

In view of these obvious facts, it is certainly unrealistic to expect field ecologists to accept as an act of faith that conclusions drawn from the study of population models built in "homogeneous time" are ecologically meaningful or useful. In order to justify our classical formulations it is necessary to demonstrate that the general properties of models with built in temporal uniformity are not substantially altered when the models are deliberately modified by building periodic features into their structure. The present pilot effort in the field of experimental theoretics is an attempt to investigate the role of periodicity by a simple direct approach.

1.3. *Periodicity.* From an intuitive standpoint, a sequence of discrete evenly spaced instants in time displays an extreme type of periodicity, evidenced by the occurrence of arbitrary periodic functions in the solution of finite difference equations. It is certainly not unusual for discrete time to be employed in models designed to represent successive generations of annual organisms [22]. Some field ecologists also seem to share this intuitive standpoint, for their investigations are usually planned to cover a whole number of annual cycles, comparisons being made at the same season in successive years. The close analogy which exists between finite difference and differential equations and their solutions also suggests *a priori* that periodicity in general might only play a subsidiary role.

Whether time is considered uniform or not depends in practice on the scale employed, and rapid quantitative changes may have qualitative effects. Just as the vibrating column of air in an organ pipe generates a sustained musical note, so might the diurnal rhythm in the long life of many animals and plants be regarded as a qualitative feature of the environment. Few organisms, however, survive so long that the same could be said of the annual seasonal rhythm.

2. Matrix representation of a population process under periodic conditions

2.1. *Matrix representation of population change.* The model, which Lotka and his associates [21], [17], [5] originally used to represent a population in continuous time, is built on the assumption that age specific birth and death

rates remain constant at all points in time, irrespective of the season of the year. In this respect the model is more readily applicable to human populations than to most animal populations in the wild. Lotka's arguments and results are stated in terms of linear integral equations and definite integrals. He found that with the passage of time, population growth (or decline) was asymptotically exponential, and that the age structure approached a stable form.

Substantially the same conclusions were also reached by Lewis [15] and independently by Leslie [13], [14], who reframed the model in discrete time. The population in a given year was represented as a vector, the elements being the number of individuals in the separate annual age classes. The direct linear relations connecting the numbers in the age classes one year with those in the appropriate age classes the previous year were displayed as a square matrix, thus

$$(2.1) \quad \begin{bmatrix} N_{0,t+1} \\ N_{1,t+1} \\ N_{2,t+1} \\ N_{3,t+1} \end{bmatrix} = \begin{bmatrix} r_0 & r_1 & r_2 & r_3 \\ S_0 & \cdot & \cdot & \cdot \\ \cdot & S_1 & \cdot & \cdot \\ \cdot & \cdot & S_2 & \cdot \end{bmatrix} \begin{bmatrix} N_{0,t} \\ N_{1,t} \\ N_{2,t} \\ N_{3,t} \end{bmatrix}, \quad \mathbf{N}_{t+1} = \mathbf{M}\mathbf{N}_t.$$

The elements in the top row are conceived as coefficients of reproduction or multiplication, and those in the subdiagonal as coefficients of survival. The interpretation adopted here is made selfevident by reference to figure 1. The

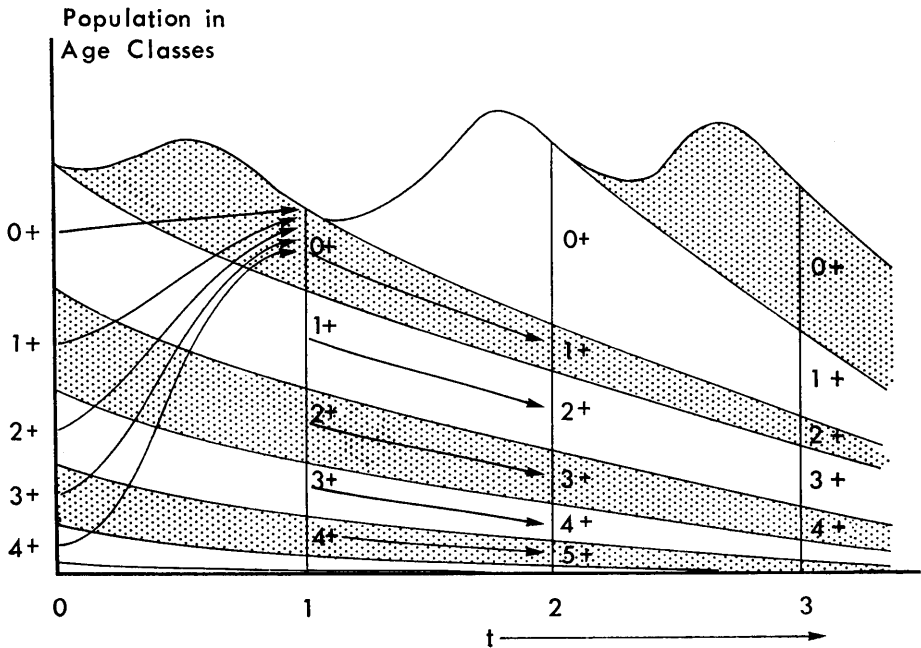

FIGURE 1
Population in age classes.

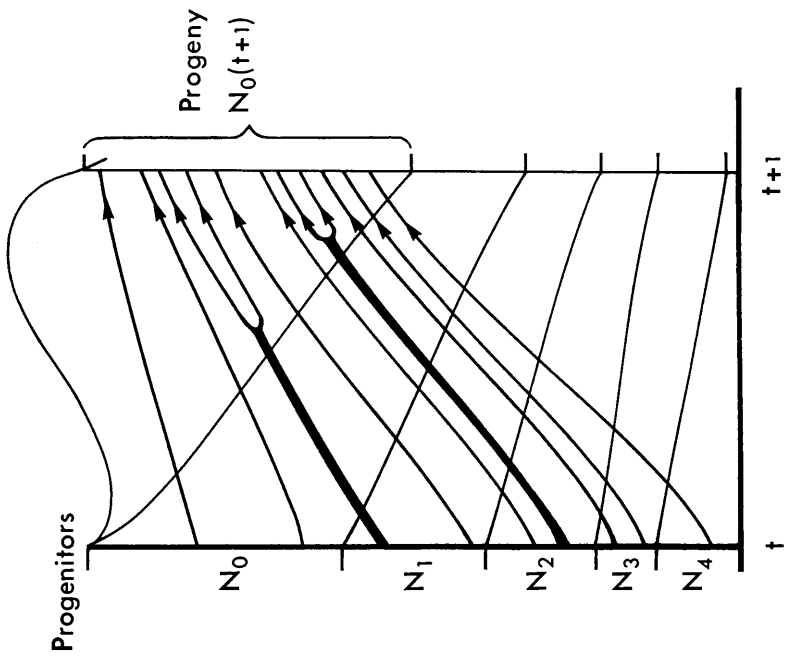
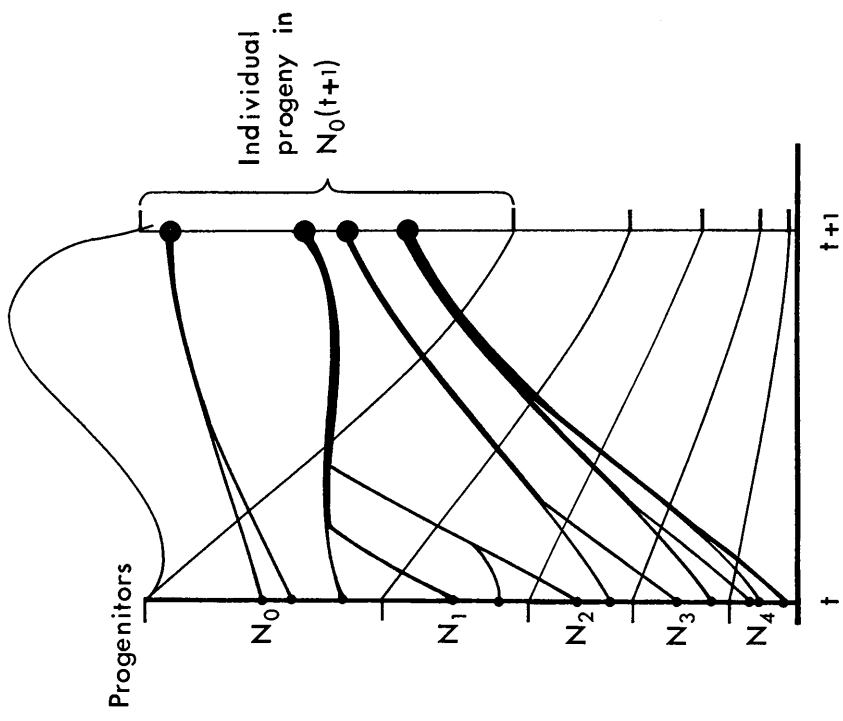

FIGURE 2

Interpretation of the coefficients r_0, r_1, r_2, \dots .

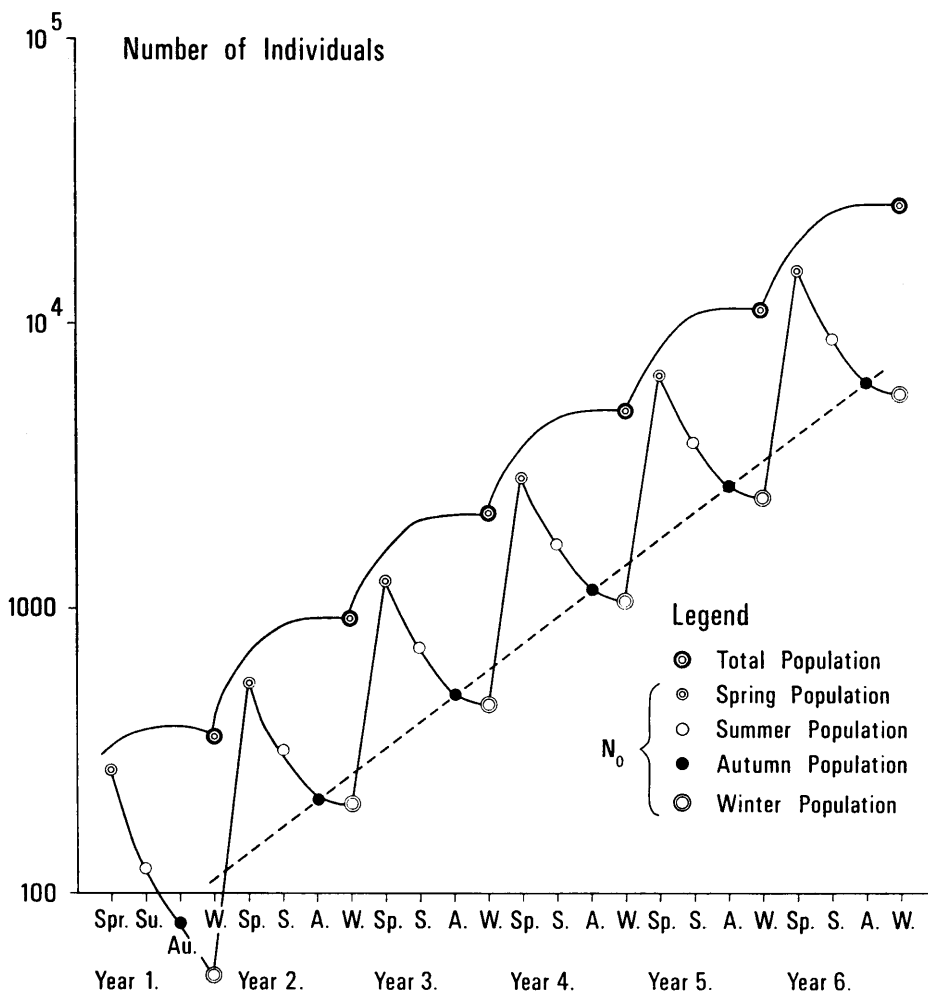

FIGURE 3

Seasonal change in number of individuals.
Numerical values taken from table I. Case $m = 4$.

population is considered as being continuous but observed only at time points $t, t + 1, t + 2, \dots$, and the individuals are classified at those instants according to their ages, $0+, 1+, 2+, \dots$. For $\alpha > 0$, $N_{\alpha,t}$ is simply related to $N_{\alpha-1, t-1}$ by survival. The manner in which the $N_{\alpha,t}$ contribute to $N_{0,t+1}$ is more complex, especially if reproduction is bisexual, or if the newly born die or reproduce before recruitment into class $0+$ at the next observation point. Even so, by apportioning the contributions made by the two parents to each offspring in an appropriate manner, by treating offspring which do not survive to recruitment as stillborn, and by treating precocious reproduction as twinning,

it is always possible to give a rational interpretation to the coefficients r_0, r_1, r_2, \dots (figure 2). It is often convenient to regard the population as asexual or alternatively as purely female, the males being disregarded as being merely part of the environment. The latter convention is adopted in the stochastic formulation given later.

The matrix representation of population change is particularly appropriate to populations of wild animals in which the reproductive season is condensed into a few weeks each year. The classification of the population into age classes is perhaps most meaningful if made as soon as the reproductive season ends. The application of matrix schemata, however, is not restricted to such cases. By taking the observation points sufficiently close together, a matrix scheme may be used as a finite difference approximation to a continuous system.

If, for example, we divide the annual cycle into n parts (say, $n = 13$ or 52) it is possible to make each matrix \mathbf{M}_s appropriate to the time of the year, and to represent regular season change by repeating the matrices in cyclical order. Thus, if time is denoted by $t = j + s/n$, where j is an integer,

$$\begin{aligned}
 \mathbf{N}_{j+1/n} &= \mathbf{M}_0 \mathbf{N}_j, \\
 \mathbf{N}_{j+2/n} &= \mathbf{M}_1 \mathbf{N}_{j+1/n} = \mathbf{M}_1 \mathbf{M}_0 \mathbf{N}_j, \\
 \mathbf{N}_{j+1+s/n} &= \mathbf{M}_{s-1} \mathbf{M}_{s-2} \cdots \mathbf{M}_0 \mathbf{M}_{n-1} \cdots \mathbf{M}_s \mathbf{N}_{j+s/n} \\
 &= \mathbf{G}_s \mathbf{N}_{j+s/n},
 \end{aligned}
 \tag{2.2}$$

where

$$\mathbf{G}_s = \mathbf{M}_{s-1} \cdots \mathbf{M}_0 \mathbf{M}_{n-1} \cdots \mathbf{M}_s.
 \tag{2.3}$$

The matrix product \mathbf{G}_s is necessarily square.

A numerical example designed to show the behavior of a population system of this kind (with $n = 4$) is illustrated in figures 3 and 4. The numerical values allotted to the matrix elements are set out in table I together with the initial vector. It will be seen that the values are not entirely unrealistic.

2.2. Seasonal population model. As is well known, the asymptotic behavior of the system, $\mathbf{N}_{t+1} = \mathbf{GN}_t$, is controlled by the latent roots and latent vectors of the matrix \mathbf{G} . If there is a single dominant latent root λ_1 , and if \mathbf{L}_1 denotes the corresponding latent vector, then the population vector \mathbf{N}_t acquires a stable limiting form

$$\mathbf{N}_{t+1} \sim \lambda_1 \mathbf{N}_t, \quad \mathbf{N}_t \sim k \lambda_1^t \mathbf{L}_1.
 \tag{2.4}$$

Here we have n equations of the type $\mathbf{N}_{t+1} = \mathbf{G}_s \mathbf{N}_t$ with $t = j + s/n$ and $s = 0, 1, \dots, n - 1$. Both intuitively and on the basis of the numerical example we would expect the population to grow in the same asymptotic manner irrespective of the season of the year at which it is measured. It is of vital importance however that this characteristic of the model should be firmly established mathematically. The following argument uses only elementary matrix theory.

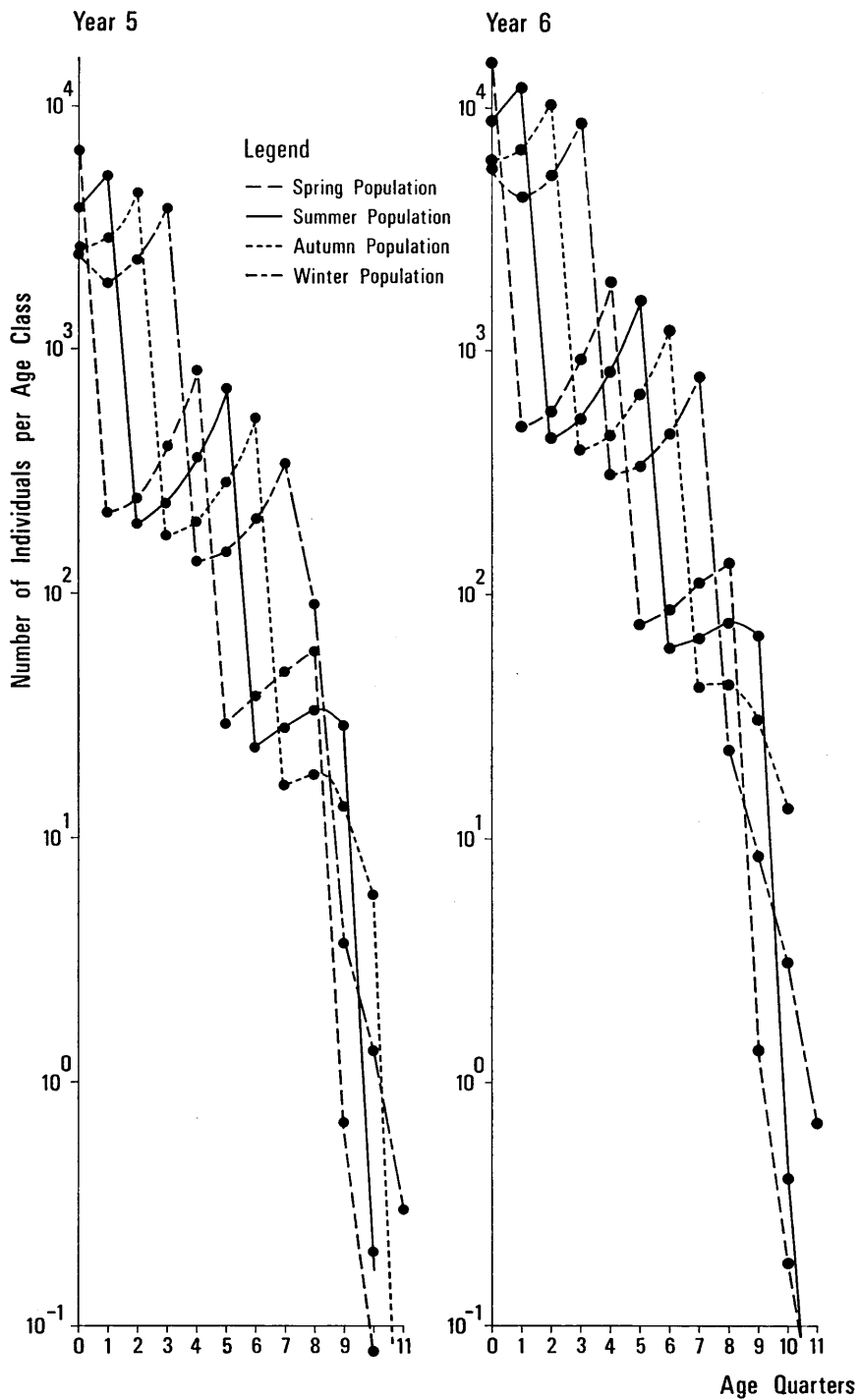

FIGURE 4

Dependence of number of individuals per age class on season when census taken.

TABLE I

EXPECTED NUMBER OF FEMALE BIRTHS (PER FEMALE PARENT) RECRUITED AT THE STATED SEASON ACCORDING TO THE AGE OF THE PARENT THE PREVIOUS SEASON

Season	Age (×4)													
		0	1	2	3	4	5	6	7	8	9	10	11	12
Midspring		0	0	0	3	3	4	5	5	5	4	3	2	0
Midsummer		0	0	0	2	3	2	4	4	3	3	2	1	0
Midautumn		0	0	0	1	2	2	3	3	3	2	1	0	0
Midwinter		0	0	0	0	1	2	3	3	2	1	0	0	0

Percentage of female individuals surviving to the next season according to their present age and season

Midwinter	20	30	40	50	55	60	55	40	15	5	0	0	0
Midspring	80	90	95	90	85	80	75	70	50	30	10	0	0
Midsummer	75	85	90	85	80	75	70	65	40	20	5	0	0
Midautumn	70	80	85	80	75	70	65	55	20	10	5	0	0

Initial winter population

	15	18	20	25	7	9	10	12	2	3	2	0	0
--	----	----	----	----	---	---	----	----	---	---	---	---	---

We already have

$$(2.5) \quad \begin{aligned} G_n &= G_0 = M_{n-1}M_{n-2} \cdots M_s M_{s-1} \cdots M_1 M_0, \\ G_s &= M_{s-1} \cdots M_0 M_{n-1} \cdots M_s. \end{aligned}$$

It will now be shown that the matrices G_0 and G_s have the same characteristic equation. The argument, which otherwise would be very simple indeed, is complicated by the fact that matrices of the form M are commonly singular owing to the presence of zeros at the extreme right of the top row. Clearly $G_0 = AB$ and $G_s = BA$, where $A = M_{n-1} \cdots M_s$ and $B = M_{s-1} \cdots M_0$. Let A be of rank ρ . Then nonsingular matrices H and K can always be found (using successive elementary operations) such that $HAK = C$, where C , the equivalent normal matrix, is a canonical diagonal form, whose elements are all zero with the exception of ρ unitary elements occupying the first ρ places in the principal diagonal (see [3], p. 86 or [8], pp. 89-90). One property of C is, that for any square matrix E (of the same order)

$$(2.6) \quad |CE - \lambda I| = |EC - \lambda I|,$$

a result which is immediately evident when these determinants are displayed in full. Now if E denotes $K^{-1}BH^{-1}$,

$$(2.7) \quad \begin{aligned} HG_0H^{-1} &= HABH^{-1} = HAK \cdot K^{-1}BH^{-1} = CE, \\ K^{-1}G_sK &= K^{-1}BAK = K^{-1}BH^{-1} \cdot HAK = EC. \end{aligned}$$

Hence

$$(2.8) \quad \begin{aligned} \mathbf{H}(\mathbf{G}_0 - \lambda\mathbf{I})\mathbf{H}^{-1} &= \mathbf{CE} - \lambda\mathbf{I}, \\ \mathbf{K}^{-1}(\mathbf{G}_s - \lambda\mathbf{I})\mathbf{K} &= \mathbf{EC} - \lambda\mathbf{I}. \end{aligned}$$

It follows, on taking determinants, that

$$(2.9) \quad |\mathbf{G}_0 - \lambda\mathbf{I}| = |\mathbf{G}_s - \lambda\mathbf{I}|.$$

The latent roots associated with \mathbf{G}_s are therefore the same for all s , and in particular those of greatest modulus.

If there is a single dominant root λ_1 , the population vectors associated with a particular season (s fixed) acquire a constancy of form characteristic of that season and undergo multiplication annually by λ_1 . The vectors associated with different seasons are tied rigidly together by relations of the type, $\mathbf{N}_{j+s/n} = (\mathbf{M}_{s-1} \cdots \mathbf{M}_0)\mathbf{N}_j$. If any one of them acquires constancy of form, the rest do so automatically. The approach to stability may therefore be described as "simultaneous."

2.3. *Use of the theorem of Frobenius.* Like stochastic matrices, population matrices, whether of form \mathbf{M} or \mathbf{G} , are necessarily made up of real nonnegative elements, and therefore fall within the scope of a weakened form of a theorem of Frobenius set out in Gantmacher ([9] Vol. 2, p. 66). According to my interpretation, the theorem implies that if the elements of a square matrix \mathbf{A} are real and nonnegative, and if the latent roots are denoted by λ_i , then either (i) all $\lambda_i = 0$, or (ii) there is a *positive* root (say λ_1), such that $\lambda_1 \geq |\lambda_i|$ for every i , and that there exists a latent vector \mathbf{L} of nonnegative real elements (not all zero) such that $\mathbf{AL} = \lambda_1\mathbf{L}$ (case ii) or $\mathbf{0}$ (case i).

On the basis of this theorem population matrices may therefore be classified for present purposes into three kinds:

- I trivial: $\lambda_i = 0$ for all i ;
- II special: $\lambda_1 > 0$, $\lambda_1 = |\lambda_i|$ for one or more $i \neq 1$;
- III stable: a single dominant root $\lambda_1 > 0$.

From the biological standpoint it is convenient to recognize at least two degrees of stability:

- III A: (low stability), the dominant root being only slightly greater than the moduli of the subdominant roots;
- III B: (high stability), the dominant root being appreciably greater than the moduli of the subdominant roots.

Class II may be regarded as the extreme limit of class III A.

The following is an example of a trivial population matrix. It will be seen that no individual survives to maturity, so that rapid extinction is inevitable.

$$(2.10) \quad \mathbf{M} = \begin{bmatrix} \cdot & \cdot & \cdot & a \\ b & \cdot & \cdot & \cdot \\ \cdot & c & \cdot & \cdot \\ \cdot & \cdot & \cdot & \cdot \end{bmatrix}, \mathbf{M}^4 = \text{null matrix}.$$

Since by definition the characteristic equation of a trivial matrix is of the form

$\lambda^n = 0$, it follows by the Cayley-Hamilton theorem (whereby every square matrix may be said to "satisfy" its own characteristic equation) that $\mathbf{M}^n =$ null matrix. This property entails total extinction after n "generations."

An example of a population matrix of the special class (II) is given below together with its nonnegative latent vector. The characteristic equation is $\lambda^3 = c^3$, whence $\mathbf{M}^3 = c^3\mathbf{I}$.

$$(2.11) \quad \begin{bmatrix} \cdot & \cdot & 6c^3 \\ \frac{1}{2} & \cdot & \cdot \\ \cdot & \frac{1}{3} & \cdot \end{bmatrix} \begin{bmatrix} 6c^2 \\ 3c \\ 1 \end{bmatrix} = c \begin{bmatrix} 6c^2 \\ 3c \\ 1 \end{bmatrix}, \quad c > 0,$$

but

$$(2.12) \quad \mathbf{M}^3 \begin{bmatrix} x \\ y \\ z \end{bmatrix} = c^3 \begin{bmatrix} x \\ y \\ z \end{bmatrix}, \quad x, y, z \text{ arbitrary.}$$

This is a slightly modified form of a matrix ($c = 1$) given in Leslie [13] in connection with a hypothetical beetle population conceived by Bernardelli [2]. The latent vector is clearly unstable, for if its elements are slightly altered arbitrarily, the resulting vector changes from generation to generation in a cyclical manner.

The example given above is readily generalized to represent any population with a stereotyped life cycle expressible in discrete generations with reproduction occurring only in the age classes, α_1+ , α_2+ , \dots α_k+ , where $1 + \alpha_1$, $1 + \alpha_2$, \dots $1 + \alpha_k$ are simple multiples of an integer $n > 1$, and where survival to the reproductive stage is possible. The characteristic equation then has the form $\lambda^n P(\lambda^n) = 0$, where P is a polynomial, and yields n dominant roots of equal modulus. This situation is very similar to that which arises in ordinary renewal theory in discrete time when the probability generating function of the primary distribution is "reducible" [23]. By analogy, population matrices may be termed "reducible" if their characteristic equation is of the form $\lambda^n P(\lambda^n) = 0$, $n > 1$. The term "reducible" is being used here in a special sense.

If each year is divided into n parts, a reducible population matrix *could* be used to describe a restricted class of seasonal populations in which (i) mortality is dependent on age but not on season, (ii) reproduction occurs at one season only, *provided that* (iii) the initial vector reflects an age distribution consistent with the times at which reproduction could have occurred. For example, with $n = 2$, we find

$$(2.13) \quad \begin{bmatrix} \cdot & r_1 & \cdot & r_3 \\ s_0 & \cdot & \cdot & \cdot \\ \cdot & s_1 & \cdot & \cdot \\ \cdot & \cdot & s_2 & \cdot \end{bmatrix} \begin{bmatrix} N_0 \\ \cdot \\ N_2 \\ \cdot \end{bmatrix} = \begin{bmatrix} \cdot \\ N_0 s_0 \\ \cdot \\ N_2 s_2 \end{bmatrix}, \quad \begin{bmatrix} \cdot & r_1 & \cdot & r_3 \\ s_0 & \cdot & \cdot & \cdot \\ \cdot & s_1 & \cdot & \cdot \\ \cdot & \cdot & s_2 & \cdot \end{bmatrix} \begin{bmatrix} \cdot \\ N_1 \\ \cdot \\ N_3 \end{bmatrix} = \begin{bmatrix} r_1 N_1 + r_3 N_3 \\ \cdot \\ s_1 N_1 \\ \cdot \end{bmatrix}.$$

If the year is the unit of time and the initial vector arbitrary, it will readily be seen that the whole population considered from a genetic standpoint is really an aggregate of n genetically distinct, interlaced, coexistent streams each reproducing every n th year. The only case which appears likely to be realized in

nature is that in which there is only one age ($\alpha_1 > 0$) at which reproduction occurs, and a number of insect populations are already known with a stereotyped life cycle which appears to conform to this pattern.

The so called "periodical Cicada" (*Magicicada septendecim* L.) of U.S.A. is a classical example, which was intensively studied by Marlatt [19], and Strandine [24]. The 17 year race in the north has been reared under field conditions from the egg. In many districts several broods of different ages are known to coexist, thus explaining the appearance of swarms of the insect several times during the 17 year cycle. A 13 year race occurs in the south. Is it pure coincidence that 13 and 17 are prime?

The study of systems, which can be described in terms of matrices of classes II and III A, would, I feel sure, throw much light on a wide variety of fundamental problems: subspeciation by separation in time; the coexistence of species with similar biology; the avoidance of endemic parasitism, and the outbreak of pests. Such studies would be immensely more valuable if consideration were given to *fortuitous irregularities in the environmental conditions* as well as the stochastic aspects of the birth and death processes occurring in the population itself. The present pioneer study, however, is primarily concerned with large populations which have high structural stability (due to genuine irreducible overlapping of reproductive generations) and regular seasonal periodicity.

2.4. *Characteristics of seasonal population model.* The seasonal population model discussed in 2.2 has three main characteristics:

- (i) there are n discrete time points in each year;
- (ii) the vital coefficients expressed as elements in the matrices are independent of the size and composition of the population;
- (iii) the conception is essentially deterministic. With regard to (i), it is apparent that by making n large enough it is possible to approximate to a system in continuous time with continuous coefficients, and that the general properties of the system will still hold. Characteristic (ii), however, is a serious defect and restricts the applicability of the system to low population densities. Even with free lateral diffusion, the density could not remain low indefinitely in a favorable environment. Approximate exponential growth could hardly be achieved in systems of low stability if density dependent factors were to operate quickly. It seems reasonable, however, to conjecture that, even where density effects operate, stability of the seasonal age structure might nevertheless be achieved as in the nonseasonal models of Lotka [18] and Leslie [14]. With regard to (iii) it may be pointed out that this deterministic system also describes the "growth in mean" (not only of the whole system but of each separate age class) of its stochastic analogue. A proof of this assertion follows.

2.5. *Stochastic analogue of Lewis-Leslie matrix model.* The stochastic analogue of the Lewis-Leslie matrix model may be formulated in general terms for an asexual or female population as follows.

Let $G_t(z_0, z_1, z_2, \dots)$ be the probability generating function of the joint distribution of the numbers in the age classes, $0+$, $1+$, $2+$, \dots at time t . Let

$g_\alpha(z_0, z_{\alpha+1})$ be the probability generating function of the joint distribution of the number of offspring and the number of survivors arising from a single individual in class α . If the processes (birth and survival) carried out by one individual are statistically independent of those performed by every other individual, the system may be regarded as an example of a generalized Galton-Watson process [11]. The homogeneity of each class is assumed. We then have

$$(2.14) \quad \mathcal{G}_{t+1}(z_0, z_1, \dots) = \mathcal{G}_t(g_0(z_0, z_1), g_1(z_0, z_2), \dots).$$

Roughly speaking, the independence assumption corresponds to an absence of competitive and density effects. The expected number of individuals in class α is obtained in the usual way by differentiating with respect to z_α and setting all $z = 1$.

If the partial derivative of \mathcal{G} with respect to the i th variable is written $\mathcal{G}^{(i)}$ and the derivative of $g_\alpha(z_0, z_{\alpha+1})$ with respect to z_i is written $g_\alpha^{(i)}(z_0, z_{\alpha+1})$, we obtain

$$(2.15) \quad \begin{aligned} \mathcal{G}_{t+1}^{(0)}(z_0, z_1, \dots) &= \sum_{\alpha} \mathcal{G}_t^{(\alpha)}(g_0, g_1, \dots) g_\alpha^{(0)}(z_0, z_{\alpha+1}), \\ \mathcal{G}_{t+1}^{(\alpha+1)}(z_0, z_1, \dots) &= \mathcal{G}_t^{(\alpha)}(g_0, g_1, \dots) g_\alpha^{(\alpha+1)}(z_0, z_{\alpha+1}). \end{aligned}$$

Noting that $g(1, 1) = 1 = \mathcal{G}(1, 1, \dots)$, and writing \bar{r}_α for $g_\alpha^{(0)}(z_0, z_{\alpha+1})|_{z_0=z_{\alpha+1}=1}$ and \bar{s}_α for $g_\alpha^{(\alpha+1)}(z_0, z_{\alpha+1})|_{z_0=z_{\alpha+1}=1}$, so that \bar{r}_α and \bar{s}_α are the expected numbers of offspring and survivors from a single individual aged α , we obtain

$$(2.16) \quad \begin{aligned} \bar{N}_{0,t+1} &= \sum_{\alpha} \bar{N}_{\alpha,t} \bar{r}_\alpha, \\ \bar{N}_{\alpha+1,t+1} &= \bar{N}_{\alpha,t} \bar{s}_\alpha. \end{aligned}$$

This result is formally identical with the original deterministic scheme, but with $\bar{N}_{\alpha,t}$, \bar{r}_α and \bar{s}_α substituted for $N_{\alpha,t}$, r_α and s_α .

The result holds for every pair of adjacent time points for which the g_α are defined. It therefore holds when g_α is replaced by $g_{\alpha s}$, where s is independent of the composition of the population and changes with time or takes on the values $0, 1, 2, \dots, n - 1$, cyclically.

3. Periodic productive processes

3.1. *Processes performed by a population.* Modern population ecology is not solely concerned with the traditional demographic aspects of population (numbers, births, deaths, life expectation) but with a wide range of processes performed by a population considered as a component in an ecosystem. It is concerned, for example, with the intake of fixed energy in the food, the utilization of that energy, its temporary storage by bodily growth, and the passing on of fixed energy to the next trophic level, notably in the bodies of the individuals which die. Such processes are clearly dependent not only on the seasonal changes in the size and composition of the population itself but also on the changing environment.

The mathematical treatment of population processes often involves substan-

tially the same mathematical operations regardless of the biological nature of the processes, and many things not normally considered as genuine processes can, with a little imagination, often be regarded as such. The symbol Φ is used here to denote any additive quantity which may be regarded as the outcome of any one of a wide class of processes, the following being typical examples:

- (i) the total fixed energy ultimately discharged by a cohort on the death of the component individuals;
- (ii) the number of deaths occurring in a defined population or subpopulation in a stated period of time;
- (iii) the amount of heat lost by all individuals born between τ_1 and τ_2 ;
- (iv) the amount of amino acid assimilated by a cohort throughout its existence;

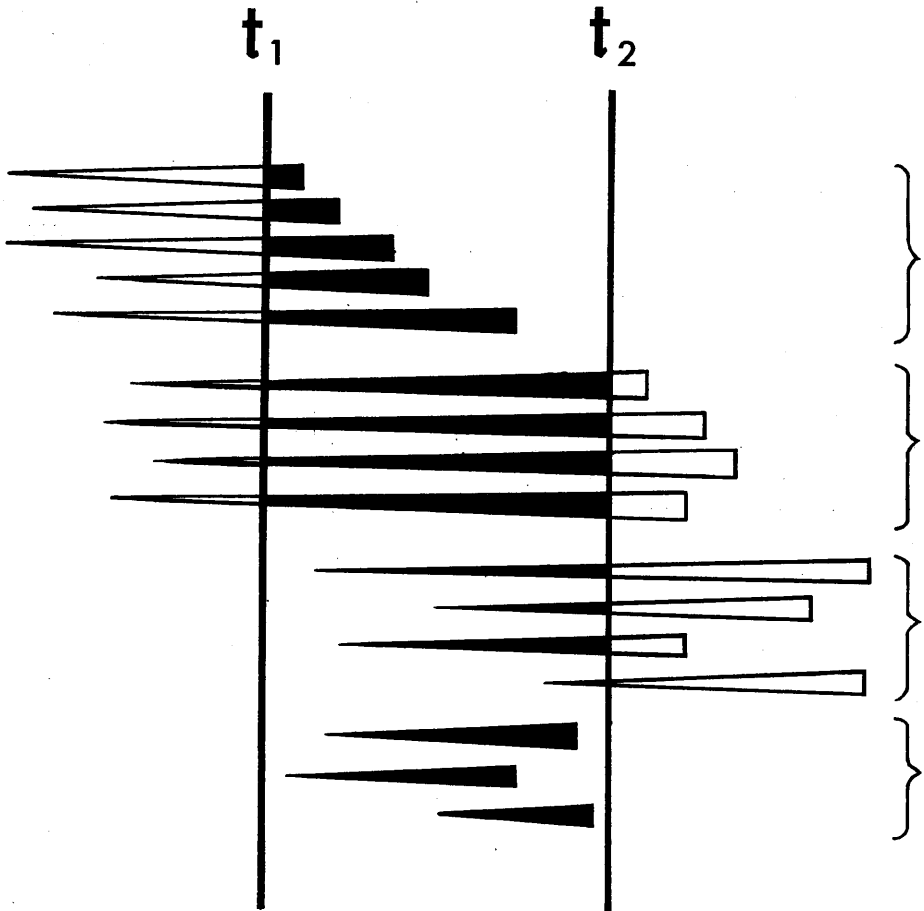

FIGURE 5

Representation of an individual by a fiber and of a population as a mass of interwoven fibers.

(v) the weight of offspring born to a defined age class in a stated period (t_1 to t_2);

(vi) the total amount of bodily growth achieved by a population in a year;

(vii) the total of the ages at death of all individuals alive at instant t .

3.2. *Geometrical representation of a population.* If we wish to speak of the change which a population undergoes between two time points, t_1 and t_2 , it must be fully defined throughout the interval. Ambiguity may arise as a result of births or deaths occurring in the interval. This consideration leads us to represent an individual by a fiber of finite length conceived as extending in time, and to regard a population as a mass of interwoven fibers similar to a rope (figure 5).

The activities of an organism at time t depend not only on the conditions prevailing at that instant but also on the stage of development which the individual has attained—a state which may be summarized (perhaps imperfectly) by its age α . The life path of an organism is not like that of a particle in a single corridor of time, for the organism is always moving progressively into a later stage of development. This consideration has already been suggested by the changing form of the fibers in figure 5. Another way of showing this additional aspect is to represent each life as an oblique line in a plane with coordinates t and α , as in figure 6. The value of t when $\alpha = 0$ is the time of birth τ .

If we make cuts ($t = t_1$, $t = t_2$) at right angles to the time axis, the figure lying between these “horizontal sections” is a “population segment.” If, however, we make oblique cuts ($\tau = \tau_1$, $\tau = \tau_2$, where $\tau = t - \alpha$) the figure lying between them refers to a particular set of successive lives, and is termed here a “population array.” A population segment and a population array based on the same time interval ($\tau_1 = t_1$, $\tau_2 = t_2$) are somewhat analogous to a rectangle and parallelogram on the same base and between the same parallels, and under certain conditions can be shown to be “equivalent.”

A region such as BAC or EDF defined by one horizontal and one oblique section ($t_0 = \tau_0$) may be termed a “population sector.” A third type of section, the “vertical section” (α fixed) is important in establishing relationships between segments and arrays.

When a population is so large that a high density of births occur per unit time, it is convenient to group the individuals into narrow cohorts, and to arrange the life lines of all individuals born in a small fixed interval above one another in order of length (with the longest at the bottom). The three dimensional result so obtained has the general form shown in figure 7.

The simplest type of region is the array because the individual lives are not cut through and the picture of survival is direct. The study of population segments is necessitated by the fact that many practical investigations are confined to or refer to a definite interval of chronological time. The overall picture of survival is so obscured by the incompleteness of many of the cohorts at one or both ends that it is not immediately apparent how best to define the survivorship function at a point in chronological time in the absence of an over-

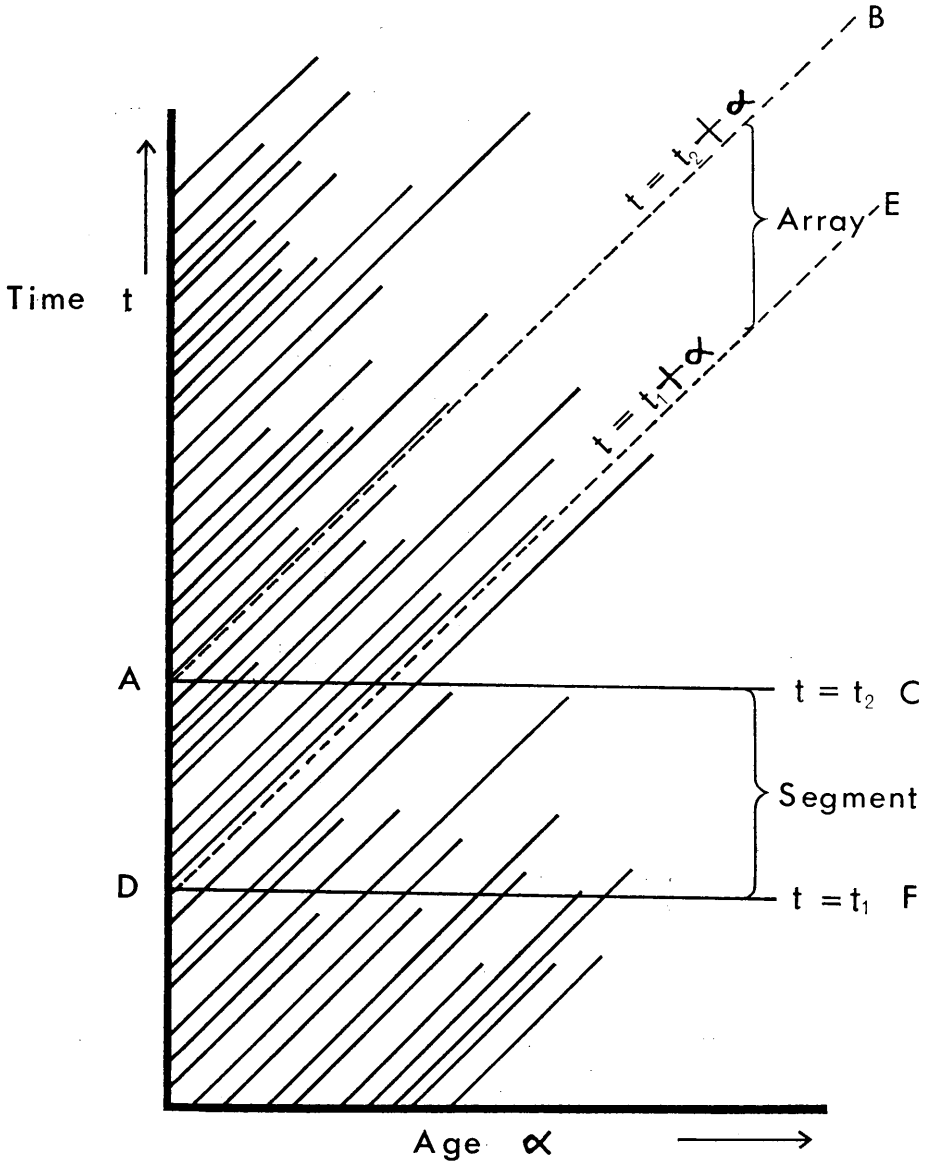

FIGURE 6

Representation of population segment and population array.

riding theoretical model. Whereas an oblique section in figure 7 describes survival, a horizontal section describes age structure.

The position of a point in the population plane is determined when any two of the three possible coordinates are given; α (age), τ (time of birth), t (actual

time prevailing). When studying an array, α and τ are most appropriate, and for studying a segment, α and t . A point in the plane may be denoted alternatively by (α, τ) or $[\alpha, t]$, where $t = \alpha + \tau$, the coordinate system adopted being

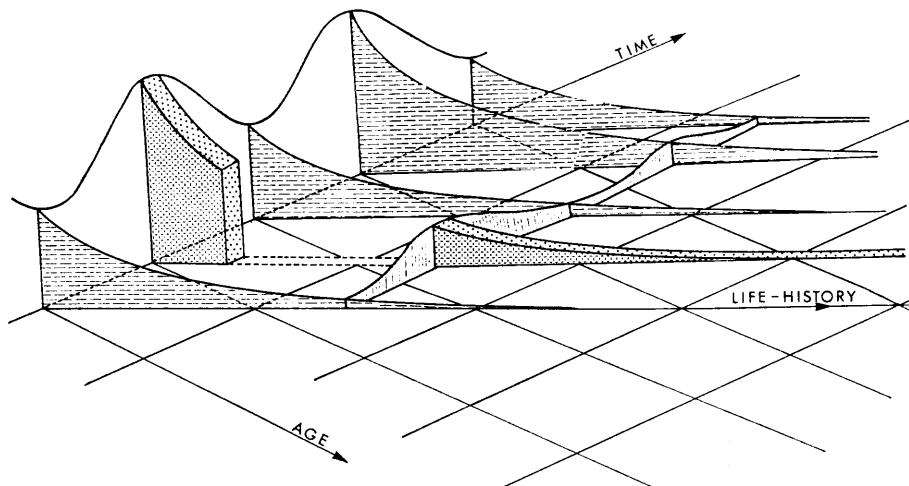

FIGURE 7

An oblique section of model describes survival,
a horizontal section describes age structure.

indicated by the form of the brackets. In order to preserve the same functional notation throughout, the symbolism,

$$(3.1) \quad f(\alpha, \tau) = f(\alpha, t - \alpha) = f[\alpha, t] = f[\alpha, \tau + \alpha],$$

is adopted. The oblique section $(0 \leq \alpha < \infty, \tau)$ is denoted by $(\cdot\tau)$, and the horizontal section $[0 \leq \alpha < \infty, t]$ by $[\cdot t]$. Where the range of variables is evident from the context, the vertical section $[\alpha, t_1 \text{ to } t_2]$ through a segment is abbreviated to $[\alpha \cdot]$, the vertical section $(\alpha, \tau_1 \text{ to } \tau_2)$ through an array to $(\alpha \cdot)$, a whole segment to $[\cdot \cdot]$, and a whole array to $(\cdot \cdot)$.

3.3. *Tracks of a cohort.* Figure 8 shows a pencil of tracks representing the basal part of a cohort born in $\tau \pm \frac{1}{2} d\tau$. At instant t the age range is $\alpha \pm \frac{1}{2} d\alpha$. The individuals attain the age α (exactly) in the time interval $t \pm \frac{1}{2} dt$. Clearly in this figure $|d\tau| = |dt| = |d\alpha|$. If the cohort is really narrow and the population extremely large, it will be apparent intuitively that both vertical and horizontal sections (through the point with coordinates α, t, τ) cut through virtually the same number of tracks, for the numbers of deaths in quadrants *A* and *B* are then approximately equal and relatively few compared with the number of tracks cut by both sections. At least it seems reasonable to construct a representation in terms of a continuous "density" function, and to image a surface above the population plane. The number of tracks cut by the vertical

section is appropriately denoted by $N(\alpha, \tau) d\tau$ or $N[\alpha, t] dt$ and the number of tracks cut by the horizontal section by $N[\alpha, t] d\alpha$ or $N(\alpha, \tau) d\alpha$.

If we now take any fixed point $[\alpha, t]$ in the plane and delimit a minute region dR in the neighborhood of that point, we confine our attention to events which

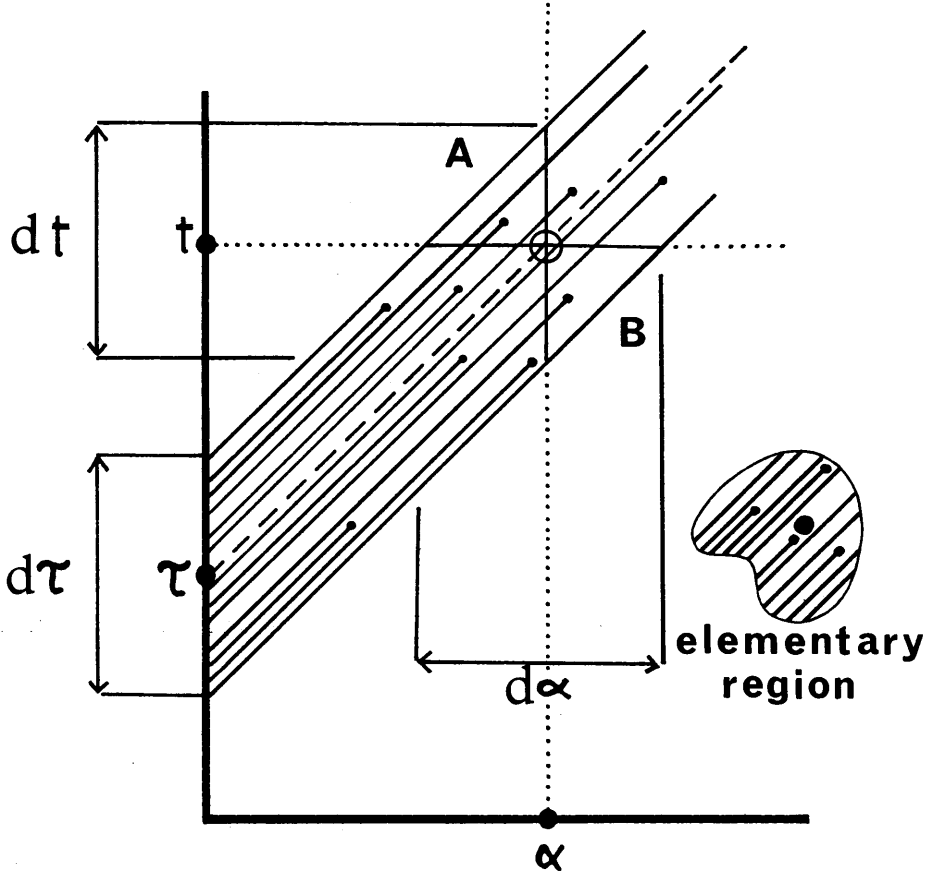

FIGURE 8

Pencil of tracks represents basal part of cohort.

are happening at virtually the same time to animals of virtually the same age, and in a statistical sense with the same past history in so far as they experienced similar conditions at the same age. The amount of biological activity associated with dR depends not only on t and α but on the total number of "animal days" included in dR , a quantity indicated diagrammatically by the amount of cross hatching included in dR (the unit of measurement being the length of track marked out by one animal in unit time).

3.4. *Properties of total outcome Φ .* If Φ is additive and denotes the total

outcome of a process attributable to the life tracks in a region R of the population plane, then in general

$$(3.2) \quad \Phi(\text{for } R) = \iint_R \Phi(\alpha, \tau) dR = \iint_R \Phi[\alpha, t] dR.$$

When R is the segment $[0 \leq \alpha < \infty, t_1 \leq t \leq t_2]$,

$$(3.3) \quad \Phi[\cdot \cdot] = \int_0^\infty \int_{t_1}^{t_2} \Phi[\alpha, t] d\alpha dt.$$

When R is the array $(0 \leq \alpha < \infty, \tau_1 \leq \tau \leq \tau_2)$,

$$(3.4) \quad \Phi(\cdot \cdot) = \int_0^\infty \int_{\tau_1}^{\tau_2} \Phi(\alpha, \tau) d\alpha d\tau.$$

Altogether there are four simple integrals involved and it is convenient to employ a separate symbol for each. Thus,

$$(3.5) \quad \Phi[\cdot t] = \int_0^\infty \Phi[\alpha, t] d\alpha, \quad \Phi(\cdot \tau) = \int_0^\infty \Phi(\alpha, \tau) d\alpha.$$

Here $\Phi[\cdot t]$ is the instantaneous rate of the process due to the whole population, and $\Phi(\cdot \tau) d\tau$ is the total result of the process ultimately achieved by the cohort born in $\tau \pm \frac{1}{2} d\tau$. Similarly,

$$(3.6) \quad \Phi[\alpha \cdot] = \int_{t_1}^{t_2} \Phi[\alpha, t] dt,$$

$$\Phi(\alpha \cdot) = \int_{\tau_1}^{\tau_2} \Phi(\alpha, \tau) d\tau.$$

These integrals may be interpreted as the total rate of the process attributable to the individuals involved as each attains the age α . Equations (3.3) and (3.4) may now be written

$$(3.7) \quad \Phi[\cdot \cdot] = \int_0^\infty \Phi[\alpha \cdot] d\alpha, \quad \Phi(\cdot \cdot) = \int_0^\infty \Phi(\alpha \cdot) d\alpha.$$

Whenever $\Phi[\alpha \cdot] = \Phi(\alpha \cdot)$, the outcome of the process is the same for both segment and array.

3.5. *Ratio of outcomes of two processes.* We may often wish to compare the outcome of a process Φ_1 in some region with the outcome of another process Φ_2 in the same region, by forming their ratio,

$$(3.8) \quad \chi(\text{for } R) = \Phi_1(\text{for } R) / \Phi_2(\text{for } R),$$

and it is logical to extend the definition of χ from a narrow region to a section (by abstraction) in the same way. Thus,

$$(3.9) \quad \chi[\alpha \cdot] = \Phi_1[\alpha \cdot] / \Phi_2[\alpha \cdot].$$

Because χ , being a ratio, is not necessarily additive, the integrals which express its value in terms of more specific local values are weighted. Thus,

$$(3.10) \quad \chi[\cdot \cdot] = \int_0^\infty \chi[\alpha \cdot] \Phi_2[\alpha \cdot] d\alpha / \Phi_2[\cdot \cdot].$$

3.6. *Strictly periodic process.* With a view to simulating seasonal change,

incorporating the regular aspects of the rhythm but ignoring superimposed irregularities, it is now assumed that the process is strictly periodic in t . This would certainly be so if *both* the characteristics of the population and the characteristics of the environment were repeated, season for season, year after year.

If $T_2 - T_1$ is an exact multiple of the period, and k is arbitrary,

$$(3.11) \quad \int_{T_1}^{T_2} \Phi[\alpha, t] dt = \int_{T_1+k}^{T_2+k} \Phi[\alpha, t] dt \\ = \int_{T_1+k-\alpha}^{T_2+k-\alpha} \Phi[\alpha, \tau + \alpha] d\tau = \int_{T_1+k-\alpha}^{T_2+k-\alpha} \Phi(\alpha, \tau) d\tau.$$

If therefore an array and a segment have equal bases, which are exact multiples of the period, $\Phi[\alpha \cdot] = \Phi(\alpha \cdot)$ and hence $\Phi[\cdot \cdot] = \Phi(\cdot \cdot)$. If $\chi = \Phi_1/\Phi_2$, where Φ_1 and Φ_2 have the same period as above, it immediately follows that $\chi[\cdot \cdot] = \chi(\cdot \cdot)$.

3.7. *Specific applications of Φ .* The expressions already given in generalized terms hold when the symbol Φ is replaced by N, D, Ω or Π , interpreted as follows:

$N[\alpha, t] d\alpha$ = number of individuals in age class $\alpha \pm \frac{1}{2} d\alpha$ at t ;

$N(\alpha, \tau) d\tau$ = number born in $\tau \pm \frac{1}{2} d\tau$ surviving to age α ;

$\Omega(\alpha, \tau) d\tau$ = total fixed energy content at age α of all individuals born in $\tau \pm \frac{1}{2} d\tau$;

$D(\alpha, \tau) d\alpha d\tau$ = number of deaths among individuals born in $\tau \pm \frac{1}{2} d\tau$ at ages between $\alpha - \frac{1}{2} d\alpha$ and $\alpha + \frac{1}{2} d\alpha$;

$\Pi(\alpha, \tau) d\alpha d\tau$ = amount of fixed energy lost from the population through death between the ages $\alpha - \frac{1}{2} d\alpha$ and $\alpha + \frac{1}{2} d\alpha$ of individuals born in $\tau \pm \frac{1}{2} d\tau$.

By taking ratios of pairs of these four additive quantities, we may define

$$(3.12) \quad \mu = D/N, \mathfrak{W} = \Pi/D, W = \Omega/N, \pi = \Pi/\Omega;$$

μ denotes mortality in the usual relative sense; $\mu(\alpha \cdot)$ and $\mu[\alpha \cdot]$, for example, are age specific mortality rates referring respectively to some defined array or segment;

\mathfrak{W} denotes the mean energy content of an individual at death;

W denotes the mean energy content of a living individual;

π denotes energy flow (in a relative sense) from a population (or conceptual subpopulation) through mortality; $\pi[\cdot t]$, for example, is the relative rate of energy flow from a whole population due to deaths at instant t .

These definitions imply that for any region, section or point of the population plane,

$$(3.13) \quad \pi/\mu = \mathfrak{W}/W.$$

It is reasonable therefore to expect π and μ to be of the same order of magnitude in most populations of wild animals.

If a population is insulated against immigration and emigration (or if these are balanced age class for age class),

$$(3.14) \quad D(\alpha, \tau) = -\frac{\partial}{\partial \alpha} N(\alpha, \tau), \quad D(\alpha \cdot) = -\frac{d}{d\alpha} N(\alpha \cdot), \quad \mu(\alpha \cdot) = -\frac{d}{d\alpha} \log N(\alpha \cdot).$$

Further definitions and basic relationships include the following: $B(T) = N(0, T) = N[0, T] = B[T]$ denotes the rate at which births occur at time T ; for a segment and an array with the same base, $B(\cdot) = B[\cdot]$; $\beta[t] = B[t]/N[\cdot t]$ is the crude relative birth rate at time t , and $\beta[\cdot] = B[\cdot]/N[\cdot \cdot]$ its overall "average" value in a population segment.

In the absence of migration, $S(\alpha, \tau) = N(\alpha, \tau)/B(\tau)$ is the survivorship function specific to the time of birth, $S(\alpha \cdot) = N(\alpha \cdot)/B(\cdot)$ its overall "average" value for an array, and $\mu(\alpha \cdot) = -(d/d\alpha)S(\alpha \cdot)$; $\lambda(\tau) = \int_0^\infty S(\alpha, \tau) d\alpha$ is the mean length of life for a cohort born at τ , and $\lambda(\cdot) = \int_0^\infty S(\alpha \cdot) d\alpha$ is the mean length of life of all individuals born to an array; $A[\alpha, t] = N[\alpha, t]/N[\cdot t]$ describes the age distribution at time t , and $A[\alpha \cdot] = N[\alpha \cdot]/N[\cdot \cdot]$ describes the overall "average" age distribution for a segment.

If a segment and array under periodic conditions have their bases equal to the same integral number of periods, then it follows almost immediately that

$$(3.15) \quad \begin{aligned} S(\alpha \cdot) &= A[\alpha \cdot]/\beta[\cdot], \\ \lambda(\cdot) &= 1/\beta[\cdot] = 1/\mu[\cdot \cdot]. \end{aligned}$$

Since $S(0 \cdot) = 1$, it follows, under the conditions already stated, that, if it is possible in practice to obtain a composite picture of the age distribution built up from observations taken evenly over all seasons of the year, it is also possible to obtain an average picture of survival, life expectation and natality.

The main reason for the multiplicity of definitions is to enable the ecologist to factorize a process into facets which may be more amenable to practical investigation separately. For example, the quantity π , which is a central concept in the study of biological productivity, may be expressed

$$(3.16) \quad \pi(\cdot \cdot) = \int_0^\infty S(\alpha \cdot) \mu(\alpha \cdot) \mathfrak{W}(\alpha \cdot) d\alpha / \int_0^\infty S(\alpha \cdot) W(\alpha \cdot) d\alpha.$$

If therefore an animal ecologist can obtain the outlines of the overall age distribution in a seasonally periodic population, he can determine S and therefore μ . If in addition he can obtain the growth function $W(\alpha \cdot)$, and make an adjustment to get $\mathfrak{W}(\alpha \cdot)$, he can then assess the value of π . By reasoning on these lines, it has been possible (on the basis of the extensive unpublished data of Dr. J. E. Satchell) to assess the value of π for the earthworm *Lumbricus terrestris* L. in woodland in N.W. England as being of the order of 1 per year despite formidable difficulties and complications connected with census work and age determination.

3.8. *Survivorship function.* Whereas $S(\alpha, \tau)$ and $S(\alpha \cdot)$ describe survival in a meaningful way, the corresponding functions, $S[\alpha, t]$ and $S[\alpha \cdot]$, do not, for they are more akin to age distributions and are not always monotonic in α .

It is therefore desirable to define a survivorship function which refers to a horizontal section. One way of doing this is to construct the pattern of survival \mathfrak{S} which would result if individuals were exposed at successive ages to the same risks of mortality as currently apply at those ages. Thus,

$$(3.17) \quad \begin{aligned} \mathfrak{S}[0, t] &= 1, \\ -\frac{\partial}{\partial \alpha} \log \mathfrak{S}[\alpha, t] &= \mu[\alpha, t], \end{aligned}$$

whence

$$(3.18) \quad \mathfrak{S}[\alpha, t] = \exp \left\{ -\int_0^\alpha \mu[a, t] da \right\}.$$

Note that \mathfrak{S} is necessarily monotonic decreasing in α , and the area under the \mathfrak{S} curve provides a definition of $\lambda[t]$, the expectation of life conceived at an instant in time. The corresponding function for a segment is

$$(3.19) \quad \mathfrak{S}[\alpha \cdot] = \exp \left\{ -\int_0^\alpha \mu[a \cdot] da \right\}.$$

As defined, these functions are indeterminate in practice if essential information is lacking at one or more ages.

If now a segment and an array under periodic and insulated conditions have bases equal to the same integral number of periods, $\mu[\alpha \cdot] = \mu(\alpha \cdot)$, whence $\mathfrak{S}[\alpha \cdot] = S(\alpha \cdot) = S[\alpha \cdot]$.

4. Mathematical description of periodic phenomena

4.1. *Simple function to describe density of births.* The most elementary purpose served by mathematics in science is description. Even so, there are not many standard periodic functions with a restricted number of parameters which are well suited to describe periodic population phenomena.

The first need is for a simple function which will describe the density of the occurrence of births or new recruits in time in such a way as to embrace cases ranging from uniformity on the one hand to a high degree of concentration on the other. When births (or the emergence of adults) are restricted to a short season, the distribution of the time of individual occurrences is usually unimodal in any one year and roughly normal. The so called "circular normal distribution" [10] could therefore be employed. An alternative is the "periodic normal distribution" derived here and illustrated in figure 9. It is conceived as having been generated by the diffusion of a point mass of material either on a closed circle or on a finite line segment with reflecting barriers, or alternatively from a sequence of evenly spaced point masses on an infinite line.

4.2. *Periodic normal distribution.* Consider first the series

$$(4.1) \quad f(x, T) = \sum_{n=1}^{\infty} n^2 e^{-n^2 T} \cos nx.$$

This is readily seen to be uniformly convergent for x real and $T \geq \epsilon > 0$,

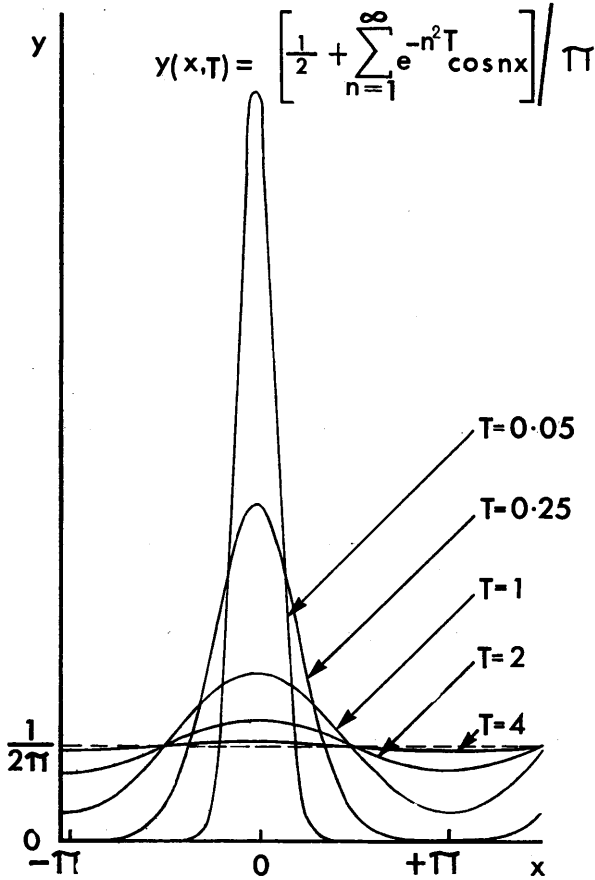

FIGURE 9
Periodic normal distribution.

where ϵ is fixed arbitrarily small. The series may therefore be integrated term by term with respect to either variable. We find that if

$$y(x, T) = \left(\frac{1}{2} + \sum_{n=1}^{\infty} e^{-n^2 T} \cos nx \right) / \pi, \tag{4.2}$$

$$\frac{\partial y}{\partial T} = \frac{\partial^2 y}{\partial x^2}, \quad \int_{-\pi}^{\pi} y(x, T) dx = 1.$$

When T is moderately large, y resembles a simple sinusoidal oscillation of low amplitude around $1/2\pi$ to which y tends as $T \rightarrow \infty$. When T is very small indeed, the function y simulates a sequence of unit point masses repeated at intervals of 2π . In fact, the formal Fourier expansion of the Dirac function is

given by setting $T = 0$. It is intuitively clear that $y(x, T)$ is positive because it describes a diffusion process starting with positive masses.

Because of its origin, it is not surprising that $y(x, T)$ satisfies the convolution theorem,

$$(4.3) \quad \int_{-\pi}^{\pi} y(x - \xi, T_1) y(\xi, T_2) d\xi = y(x, T_1 + T_2).$$

This theorem is in fact a particular case of a more general convolution theorem which applies to all functions defined on a circle by uniformly and absolutely convergent Fourier series. If

$$(4.4) \quad F(x) = \left\{ \frac{1}{2} e^{b_0} + \sum_{n=1}^{\infty} e^{b_n} \cos [n(x - a_n)] \right\} / \pi,$$

$$\Phi(x) = \left\{ \frac{1}{2} e^{\beta_0} + \sum_{n=1}^{\infty} e^{\beta_n} \cos [n(x - \alpha_n)] \right\} / \pi,$$

then their convolution taken round the circle is

$$(4.5) \quad F(x) * \Phi(x) = \left\{ \frac{1}{2} e^{B_0} + \sum_{n=1}^{\infty} e^{B_n} \cos [n(x - A_n)] \right\} / \pi,$$

where $B_n = b_n + \beta_n$ and $A_n = a_n + \alpha_n$. The coefficients add like cumulants in ordinary distribution theory.

4.3. *Application to temporal phenomena.* In order to employ the distribution given above to temporal phenomena in which the period is the unit of time, the substitutions, $x = 2\pi t$ and $T = k$, are now made. The resulting density function is

$$(4.6) \quad R(t, k) = 1 + 2 \sum_{n=1}^{\infty} e^{-n^2 k} \cos 2\pi n t,$$

for which $R(t, \infty) = 1$ and

$$(4.7) \quad \int_{-1/2}^{1/2} R(t, k) dt = 1.$$

If now

$$(4.8) \quad Q(t, k) = \sum_{n=1}^{\infty} e^{-n^2 k} \frac{\sin 2\pi n t}{n\pi},$$

it will be seen that $\int_0^t R(t, k) dt = t + Q(t, k)$.

The form of $Q(t, k)$ is illustrated in figure 10. If $k \rightarrow 0$, the curve becomes serrated and $t + Q$ is then a simple step function, being the cumulative curve of a sequence of unit point masses spaced at unit intervals.

4.4. *Advantage of standardized periodic functions.* One of the main advantages to be gained by using standardized periodic functions like $R(t, k)$ is that they can be used as modifiers of the vital coefficients β and μ , to induce periodicity into our models and yet enable us in simple cases to obtain results which are

directly comparable with those which would arise if the coefficients were constant. Indeed, constancy is included as a special case because $R(t, \infty) = 1$ and $Q(t, \infty) = 0$.

As a simple example, consider a population with a reproductive time lag due

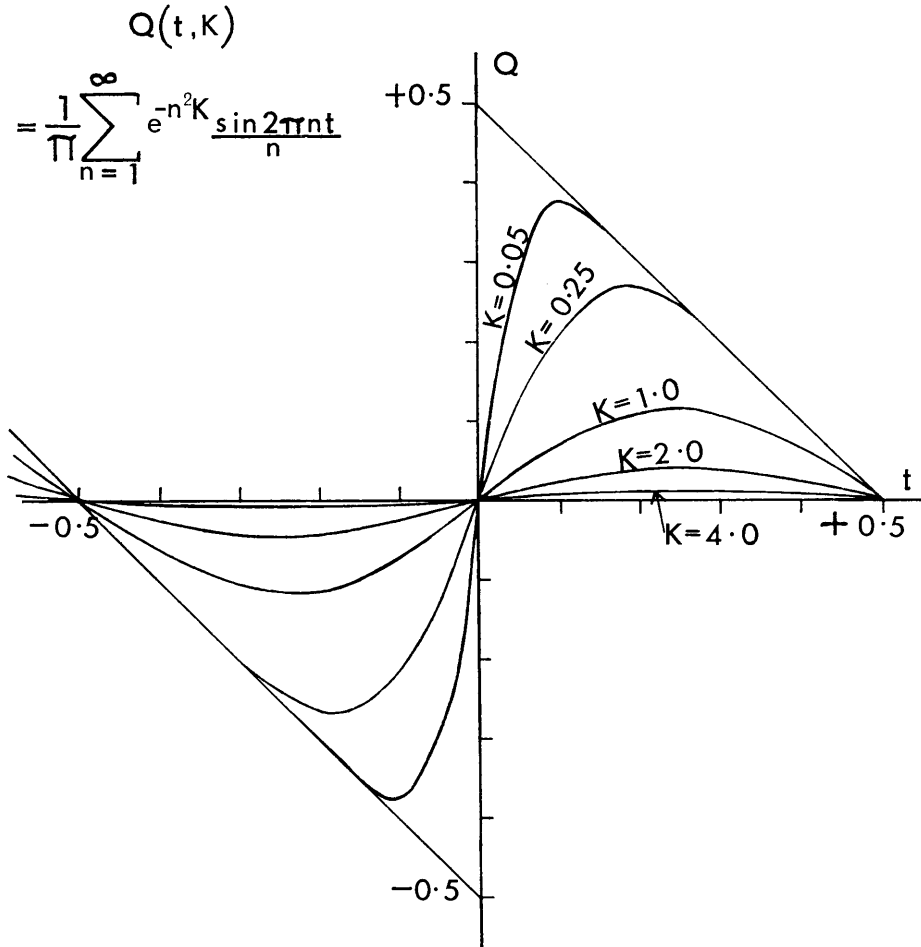

FIGURE 10
Form of $Q(t, k)$.

to the attainment of maturity at age α (an integer). The mortality rate of the immature forms is taken to be $mR_0(t) = mR(t + a, \kappa)$, say. The mortality rate of the adults is $\mu R_2(t) = \mu R(t + d, k)$, say. The birth rate (per adult) is $\beta R_1(t) = \beta R(t + b, K)$, say. The adult population is denoted by $N(t)$, and is regarded as insulated against migration.

The proportion of offspring surviving from birth at instant τ to maturity at $\tau + \alpha$ is

$$(4.9) \quad p = \exp \left\{ -m \int_{\tau}^{\tau+\alpha} R(t + \alpha, \kappa) dt \right\} = e^{-\alpha m},$$

which is independent of τ . The rate of entry of recruits to the adult population at time t is then

$$(4.10) \quad p\beta R_1(t - \alpha) N(t - \alpha) = p\beta R_1(t) N(t - \alpha).$$

The differential difference equation satisfied by N is then

$$(4.11) \quad \frac{dN(t)}{dt} = -\mu R_2 N(t) + p\beta R_1 N(t - \alpha)$$

or

$$(4.12) \quad \frac{1}{N} \frac{dN}{dt} = -\mu R_2 + p\beta R_1 \frac{N(t - \alpha)}{N(t)}.$$

Now because it is always possible to achieve an arbitrarily high degree of approximation to a population system of this kind by means of a matrix representation of the form $\mathbf{N}_{t+1} = \mathbf{G}_s \mathbf{N}_t$ (see section 2) using a sufficiently fine subdivision of the time scale, it is to be expected that $N(t - \alpha)/N(t) \sim$ positive constant (say, $g = e^{-\alpha r}$). With this substitution we obtain

$$(4.13) \quad \log N(t) \sim \text{const.} + rt - \mu Q_2 + p\beta g Q_1,$$

where r is the real root of $r + \mu = \beta e^{-\alpha(r+m)}$.

The asymptotic solution of the corresponding homogeneous hystero-differential equation with constant coefficients is perhaps more satisfactorily obtained by employing the Laplace transform and taking the dominant term [1]. It will be found that

$$(4.14) \quad \log N(t) \sim \text{const.} + rt,$$

where r takes the same value as before.

REFERENCES

- [1] R. BELLMAN and K. L. COOKE, *Differential-Difference Equations*, New York and London, Academic Press, 1963.
- [2] H. BERNARDELLI, "Population waves," *J. Burma Res. Soc.*, Vol. 31 (1941), pp. 1-18.
- [3] F. BOWMAN, *An Introduction to Determinants and Matrices*, London, English Universities Press, 1962.
- [4] L. C. COLE, "Sketches of general and comparative demography," *Cold Spring Harbor Symp. Quant. Biol.*, Vol. 22 (1957), pp. 1-15.
- [5] L. I. DUBLIN and A. J. LOTKA, "On the true rate of natural increase as exemplified by the population of the United States, 1920," *J. Amer. Statist. Assoc.*, Vol. 20 (1925), pp. 305-339.
- [6] W. FELLER, "Die Grundlagen der Volterraschen Theorie des Kampfes ums Dasein in wahrscheinlichkeitstheoretischer Behandlung," *Acta Biotheor.*, Vol. 5 (1939), pp. 11-40.
- [7] R. A. FISHER, "The distribution of gene ratios for rare mutations," *Proc. Roy. Soc. Edinburgh*, Vol. 50 (1930), pp. 205-220.

- [8] R. A. FRAZER, W. J. DUNCAN, and A. R. COLLAR, *Elementary Matrices*, Cambridge, Cambridge University Press, 1938.
- [9] F. R. GANTMACHER, *The Theory of Matrices* (translated by K. A. Hirsch), New York, Chelsea, 1959, Vol. 2, p. 66.
- [10] E. J. GUMBEL, J. A. GREENWOOD, and D. DURAND, "The circular normal distribution: theory and tables," *J. Amer. Statist. Assoc.*, Vol. 48 (1953), pp. 131-152.
- [11] T. E. HARRIS, *The Theory of Branching Processes*, Berlin, Springer-Verlag, 1963.
- [12] D. G. KENDALL, "On some modes of population growth leading to R. A. Fisher's logarithmic series distribution," *Biometrika*, Vol. 35 (1948), pp. 6-15.
- [13] P. H. LESLIE, "On the use of matrices in certain population mathematics," *Biometrika*, Vol. 33 (1945), pp. 183-212.
- [14] ———, "Some further notes on the use of matrices in population mathematics," *Biometrika*, Vol. 35 (1948), pp. 213-245.
- [15] E. G. LEWIS, "On the generation and growth of a population," *Sankhyā*, Vol. 6 (1942), pp. 93-96.
- [16] C. LINNÆUS, "Oratio de telluris habitabilis incremento," delivered to the Royal Academy of Uppsala, April 12, 1743, and published together with an essay by A. Celsius, Lugduni Batavorum, Cornelium Haak, 1744. (A copy marked "E. Bibl. Linn. propria" is held by the Linnaean Society of London.)
- [17] A. J. LOTKA, "The stability of the normal age distribution," *Proc. Nat. Acad. Sci. U.S.A.*, Vol. 8 (1922), pp. 339-345.
- [18] ———, "The structure of a growing population," *Hum. Biol.*, Vol. 3 (1931), pp. 459-493.
- [19] C. L. MARLATT, "The periodical cicada," *Bulletin of the Bureau of Entomology*, U. S. Department of Agriculture, No. 71 (1907), pp. 1-181.
- [20] J. NEYMAN, T. PARK, and E. L. SCOTT, "Struggle for existence—the *Tribolium* model: biological and statistical aspects," *Proceedings of the Third Berkeley Symposium on Mathematical Statistics and Probability*, Berkeley and Los Angeles, University of California Press, 1956, Vol. 4, pp. 41-80.
- [21] F. R. SHARPE and A. J. LOTKA, "A problem in age distribution," *Phil. Mag.*, Vol. 21 (1911), pp. 435-438.
- [22] J. G. SKELLAM, "Random dispersal in theoretical populations," *Biometrika*, Vol. 38 (1951), pp. 196-218.
- [23] J. G. SKELLAM and L. R. SHENTON, "Distributions associated with random walk and recurrent events," *J. Roy. Statist. Soc. Ser. B*, Vol. 19 (1957), pp. 64-118.
- [24] E. J. STRANDINE, "A quantitative study of the periodical cicada with respect to soil of three forests," *Amer. Midland Natur.*, Vol. 24 (1940), pp. 177-183.
- [25] P. F. VERHULST, "Notice sur la loi que la population suit dans son accroissement," *Corresp. Math. et Phys.*, A. Quetelet, Vol. 10 (1838), pp. 113-121.