

## A ROUGH FUNDAMENTAL DOMAIN FOR TEICHMÜLLER SPACES

BY LINDA KEEN

Let  $T(S)$  be the Teichmüller space of Riemann surfaces of finite type and let  $M(S)$  be the corresponding modular group. In [11] we described  $T(S)$  in terms of real analytic parameters. In this paper we determine a subspace  $R(S)$  of  $T(S)$  which is a "rough fundamental domain" for  $M(S)$  acting on  $T(S)$ . The construction of  $R(S)$  is a generalization of the constructions in [14] and [15]. The previous constructions depended heavily upon an analysis of the action of the elements of  $M(S)$  on parameters of  $T(S)$  corresponding to disjoint closed geodesics on  $S$ , and on a theorem of Bers [2] which gives bounds for the lengths of these curves. In the general case, the disjoint closed geodesics of Bers' theorem no longer always correspond directly to the parameters. Hence we must carefully study how their lengths are related to the parameters.

In §1 we outline the basic preliminary notions relating hyperbolic geometry, Fuchsian groups and Teichmüller spaces.

In §§2 and 3 we give the constructions of Teichmüller space and of a fundamental domain for the action of the modular group in the simplest cases; that is, where  $S$  has type  $(0; 3)$  and  $(1; 1)$ .

In §4 we give a detailed discussion of the Teichmüller space and of the fundamental domain in the case  $(0; 4)$ . These constructions are the heart of the general constructions which follow.

In §5 we discuss the special case of surfaces of genus 2 and state Bers' theorem. In §6 we give the construction of Teichmüller space in general.

In §7 we analyze the topologically distinct sets of mutually disjoint geodesics which occur in Bers' theorem and determine their relationship to the moduli curves.

Finally, in §8 we put all the pieces of the construction together and determine the rough fundamental domain.

In §9 we use this construction to affirmatively settle a conjecture of Bers [3].

**1. Preliminaries.** Let  $S$  be a compact Riemann surface of genus  $g$  from which  $n$  points and  $m$  conformal disks have been removed. Assume, moreover, integers  $\nu_i$  have been assigned to the  $n$  points,  $2 \leq \nu_1 \leq \dots \leq \nu_n \leq \infty$ .  $S$  is said to be of type  $(g; n; m)$  or have signature  $(g; n; m; \nu_1, \dots, \nu_n)$ .

Let  $S$  be such a Riemann surface and let  $\mathfrak{B}$  be a canonical basis for the fundamental group of  $S$ ,  $\pi_1(S)$ :

---

An Invited Address presented at the Annual Meeting, January 23, 1975, in Washington, D. C.; received by the editors December 3, 1976.

*AMS (MOS) subject classifications* (1970). Primary 30A58, 30A46, 30A60, 32G15; Secondary 30A48, 14H15, 20E40.

© American Mathematical Society 1977

$$\mathfrak{B} = \langle \alpha_1, \beta_1, \alpha_2, \beta_2, \dots, \alpha_g, \beta_g, \gamma_1, \dots, \gamma_{n+m} \rangle.$$

The elements of  $\mathfrak{B}$  satisfy the relations  $\gamma_1^{p_1} \sim \gamma_2^{p_2} \sim \dots \sim \gamma_n^{p_n} \sim 1$ ,  $\alpha_1 \beta_1 \alpha_1^{-1} \beta_1^{-1} \dots \alpha_g \beta_g \alpha_g^{-1} \beta_g^{-1} \gamma_1 \dots \gamma_m \sim 1$ . Another basis  $\mathfrak{B}'$  is equivalent to  $\mathfrak{B}$  if there is a curve  $\sigma$  such that each element  $\alpha'_i$  (respectively,  $\beta'_i, \gamma'_i$ ) of  $\mathfrak{B}'$  can be written  $\sigma \alpha_i \sigma^{-1}$  (respectively,  $\sigma \beta_i \sigma^{-1}, \sigma \gamma_i \sigma^{-1}$ ).  $S$  with an equivalence class of bases  $[\mathfrak{B}]$  is called a *marked surface*, and the space of marked surfaces of given signature constitutes the Teichmüller space  $T(S)$  of surfaces of that signature.

If  $d = 6g - 6 + 2n + 3m > 0$ , the universal covering surface of  $S$  is conformally equivalent to the upper half plane  $U$ .  $\pi_1(S)$  is isomorphic to a Fuchsian group  $\Gamma$  determined up to normalization, and the equivalence class of  $\mathfrak{B}$  determines a canonical *presentation*

$$\begin{aligned} \mathfrak{S} = \{ & A_1, B_1, \dots, A_g, B_g, C_1, \dots, C_{n+m}, \\ & C_1^{p_1} = C_2^{p_2} = \dots = C_n^{p_n} = C_{m+n} C_{m+n-1} \\ & \dots C_2 C_1 B_g^{-1} A_g^{-1} B_g A_g \dots B_1^{-1} A_1^{-1} B_1 A_1 = 1 \} \end{aligned}$$

of  $\Gamma$ . We say “ $\Gamma$  represents  $S$ ” via the projection map  $\pi: U \rightarrow U/\Gamma$ . In this way we have a uniquely determined identification between the space  $T(S)$  and the space of Fuchsian groups with canonical presentation or *marked groups*.

We can define the Poincaré metric  $ds = |dz|/y$  on  $U$  and note that  $\Gamma$  acts as a group of isometries with respect to this metric. The geodesics in  $U$  are circles orthogonal to the real axis  $\mathbf{R}$ . To each element  $A$  of  $\Gamma$  with two real fixed points (hyperbolic element) we can associate a unique geodesic, the geodesic through the fixed points. We call this geodesic  $h_A$ , the axis of  $A$ . It is left invariant by  $A$  and all its points are moved in one direction: toward the attracting fixed point. In what follows, we will make the simplifying assumption that all elements of  $\Gamma$  are hyperbolic. This is equivalent to assuming  $n = 0$ . The cases  $n > 0$  can be treated by similar techniques. We will write the signature or type of our surface  $(g; m)$ . We define the *intrinsic metric* on  $S$  as the metric on  $S$  induced from  $U$  via the projection  $\pi$ .

Each element of  $\Gamma$  now has an axis. These axes project onto closed geodesics on  $S$ . Moreover, conjugate axes project onto the same geodesic. Conjugacy classes of elements of  $\Gamma$  correspond to free homotopy classes of curves on  $S$  and the geodesic which is the projection of the axes of the elements in the conjugacy class is the unique geodesic in the free homotopy class. This geodesic has a well-defined length  $\delta$ .  $\delta$ , and the absolute value,  $k$ , of the trace of the conjugacy class of elements of  $\Gamma$  are real analytically related;  $k = 2 \cos g(\delta/2)$ . We will use these lengths or, equivalently, traces as “natural parameters” in the Teichmüller spaces we construct.

The projections of the axes of the generators  $C_1, \dots, C_m$  are curves homotopic to the (removed) boundaries of the removed disks. The removed disks make the surface appear to have infinite, ever-widening funnels and the geodesics go around the narrowest part of these funnels. Suppose we have two surfaces each of which has a funnel such that the corresponding geodesics have the same length. We can truncate each of the surfaces along its geodesic and obtain a new surface by gluing the two resulting surfaces

together along the geodesics. Of course there is freedom to twist one of the surfaces during the gluing process. The questions of describing and determining this “twist” will be carefully studied in the constructions below. Group theoretically, what happens is the following. If  $\Gamma_1$  is the group representing the first surface and  $C_1$  an element whose axis projects to the geodesic along which we cut, if  $\Gamma_2$  is the group representing the second surface and  $C_2^{-1}$  an element whose axis projects onto the corresponding truncating geodesic, then the new surface is represented by  $\Gamma = \Gamma_1 * \Gamma_2 \text{ am}\{C_1 = C_2^{-1}\}$ . How the twist enters in this amalgamation process is critical and will be discussed at length later.

We will use the gluing procedure to build our Teichmüller spaces for surfaces of any given finite type from the spaces corresponding to the particularly simple surfaces of signatures (0; 3) and (1; 1).

After we construct the Teichmüller space, we will ask which marked surfaces in this space have the same conformal structure. This is equivalent to asking which automorphisms of the group  $\Gamma$  arise from orientation preserving homeomorphisms of the underlying surface. Homeomorphisms homotopic to the identity yield equivalent markings and correspond to inner automorphisms. Since the automorphisms in question arise from homeomorphisms, the “funnels” are either left invariant or interchanged. Consequently, we want to look at those outer automorphisms which either leave the generators  $C_1, \dots, C_m$  fixed or send them into conjugates of one another. The group  $M(S)$  of such outer automorphisms modulo the inner automorphisms is called the *Teichmüller modular group* or the *mapping class group*. It is generated by automorphisms arising from homeomorphisms called Dehn twists. These twists can be described roughly as follows: cut the surface along a simple closed curve, twist one end by  $360^\circ$  and reglue. For surfaces of simple type, a full presentation of generators (coming from Dehn twists) and relations is known. For other surfaces of finite type, generators are known. These results are more fully discussed in [4], [5], [6] and [16].

$M(S)$  acts discontinuously on  $T(S)$ ; the space  $R(S) = T(S)/M(S)$  is well defined. Below we will try to determine its structure.

## 2. Surfaces of type (0; 3).

2A. The simplest groups with  $d > 0$  are free groups on two generators. We have two distinct cases to consider. In the first, the geodesics corresponding to the generators don't intersect and the surface is of type (0; 3); in the second they do and the surface is of type (1; 1).  $d = 3$  in both these cases.

In the first case, (0; 3), the group  $\Gamma$  has a presentation  $(C_1, C_2, C_3)$  and there are three disjoint geodesics on the surfaces corresponding to these generators. It is natural to take the traces (or lengths) of these generators (geodesics) as parameters. Uniformization theory tells us that to each such marked surface there is a Fuchsian group and so the traces are determined. (See [1], [10].) On the other hand, given the three numbers  $k_i = \text{trace } C_i$ ,  $i = 1, 2, 3$ , we will construct the group.

The group is determined up to normalization, so we may assume the axis of  $C_1$  is  $(0, \infty)$  directed toward 0. Furthermore, we may assume the axis of  $C_2$  has  $+1$  as its attracting endpoint. The condition that the axes don't intersect (since their projections don't) translates to

$$(2.1) \quad k_1^2 + k_2^2 + k_3^2 - k_1k_2k_3 - 2 > 2.$$

The left-hand side of this inequality is trace  $[C_1, C_2]$ , where  $[C_1, C_2] = C_2^{-1}C_1^{-1}C_2C_1$ . This condition coupled with the normalization assumptions imply the fixed points of  $C_2C_1$  are both greater than 1. This last condition implies further that  $k_1k_2k_3 < 0$ . Therefore, we may assume  $k_i < -2$ , and the generators explicitly are

$$C_1 = \begin{pmatrix} (k_1 + K_1)/2 & 0 \\ 0 & (k_1 - K_1)/2 \end{pmatrix}, \quad C_2 = \begin{pmatrix} (k_2 + J)/2 & -(K_2 + J)/2 \\ -(K_2 - J)/2 & (k_2 - J)/2 \end{pmatrix},$$

$$C_3 = \begin{pmatrix} (2k_3 - k_2K_1 - k_1J)/4 & (-K_1K_2 + Jk_1 + k_1K_2 - JK_1)/4 \\ (-JK_1 - Jk_1 + k_1K_2 + K_1K_2)/4 & (2k_3 + k_2K_1 + k_1J)/4 \end{pmatrix},$$

where  $K_i = \sqrt{k_i^2 - 4}$  and  $J = -(k_1k_2 - 2k_3)/K_1$  (see [11]).

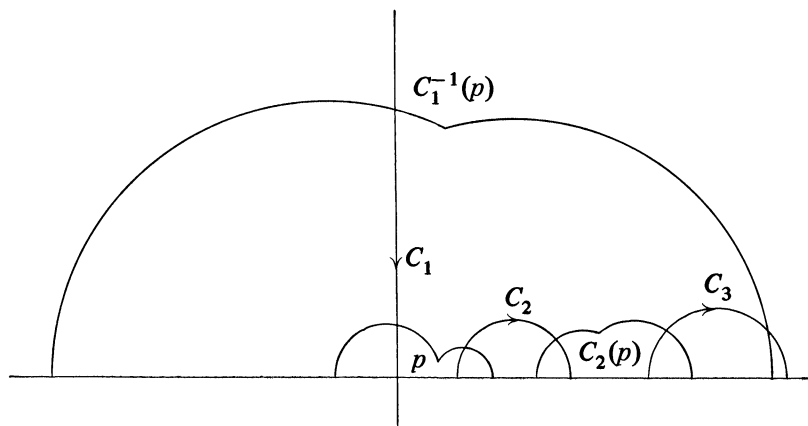

FIGURE 1

Once we have these transformations we can find the intersection point  $p$  of the axes of  $C_1C_2^{-1}$  and  $C_2^{-1}C_1$ , its images  $p_1 = C_2(p)$  and  $p_2 = C_1^{-1}(p)$ , and join them as in Figure 1 by geodesic lines. We check easily that the conditions of Poincaré [24] are fulfilled and, consequently, that the group generated by  $C_1$  and  $C_2$  is Fuchsian. We have, in summary,

**THEOREM 2.1.** *The Teichmüller space of Riemann surfaces of type (0; 3) is represented by the cell in  $\mathbf{R}^3$  determined by  $-k_1, -k_2, -k_3 > 2$ .*

**2B.** The groups  $\Gamma = \langle C_1, C_2 \rangle$  admit no nontrivial outer automorphisms which send the conjugacy classes of the elements  $C_1, C_2, C_2C_1$  into each other. That is,  $M(S) = \{\text{identity}\}$ ; hence we have

**THEOREM 2.2.** *If  $S$  is a surface of type (0; 3) the space  $R(S)$  is represented by a cell in  $\mathbf{R}^3$  determined by the inequalities  $-k_1, -k_2, -k_3 > 2$ .*

**3. Surfaces of type (1; 1).**

**3A.** Let us consider now the other case of free groups on two generators. These groups represent surfaces of type (1; 1). Since their presentations have the form  $\langle A, B, C = B^{-1}A^{-1}BA \rangle$ , it would at first seem that the moduli we should consider are the traces of  $A, B$  and  $C$ . However, from the previous

section, inequality (2.1), and the fact that  $C$  must also be hyperbolic, it follows that if we let  $x = \text{trace } A$ ,  $y = \text{trace } B$ ,  $z = \text{trace } AB$  and  $k = \text{trace } C$ , we must have

$$(3.1) \quad k = x^2 + y^2 + z^2 - xyz - 2 < -2.$$

Given  $x, y$  and  $k$  we have two choices for  $z$ . Each choice corresponds to an opposite orientation of the surface. Consequently, we must choose  $x, y, z$  and  $k$  satisfying relation (3.1) to determine our space. Given such a triple,  $(x, y, z)$ , we construct a group  $\Gamma$  by constructing a fundamental polygon as we did before. We take the intersection point of the axes of  $A$  and  $B$  as a starting point. The result is shown in Figure 2. The hexagon is nondegenerate because of the angle preserving nature of the elements of  $\Gamma$  and the hyperbolicity of the Poincaré geometry. See [10], [11] for a detailed discussion. We summarize:

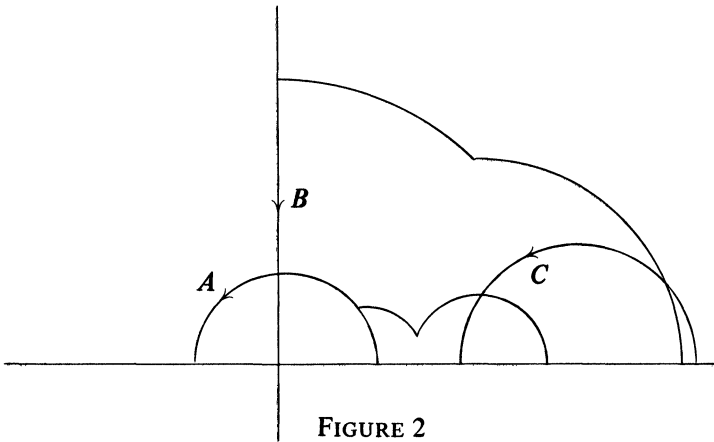

FIGURE 2

**THEOREM 3.1.** *The Teichmüller space of surfaces of type (1; 1) can be represented as the three manifold,  $\mathfrak{N}$ , in  $\mathbf{R}^4$  determined by the relations  $x^2 + y^2 + z^2 - xyz - 2 = k, x, y, z, -k > 2$ .*

3B. The Teichmüller modular group in this case is isomorphic to the usual modular group. To see this we look at  $\Phi_2$ , the group of automorphisms of a free group on two generators. By a theorem of Neumann [16], every element of  $\Phi_2$  leaves the conjugacy class of the generator  $C$  unchanged. Hence every element of  $\Phi_2$  corresponds to a homeomorphism of the surface. However,  $\Phi_2$  induces orientation reversing homeomorphisms as well as orientation preserving ones and so  $M(S)$  is a subgroup of index two in  $\Phi_2$ . We look at a standard presentation of generators of  $\Phi_2$  and take pairs to determine the action of  $M(S)$  on the moduli. The resulting generators acting on the moduli leave  $k$  invariant and act on  $x, y, z$  as follows:

$$S: x \rightarrow z, y \rightarrow x, z \rightarrow y, \quad T: x \rightarrow x, y \rightarrow xy - z, z \rightarrow y, \\ S^3 = 1, \quad (T \circ S)^2 = 1.$$

In [14] we proved

**THEOREM 3.2.** *The subdomain of  $\mathfrak{N}$  defined by the inequalities  $x \leq y$ ,*

$x < z, xz \geq 2y, xy \geq 2z$  is a fundamental domain for the group  $M(S)$  acting on the space  $T(S)$ .

The proof is similar to that of Theorem 4.3 below, which we carry out in this paper.

#### 4. Surfaces of type (0; 4).

4A. The Teichmüller spaces of surfaces of type  $(g; m)$  are built out of the ones we have just constructed for surfaces of types (0; 3) and (1; 1). The gluing together process and construction of the appropriate moduli is most easily seen in the (0; 4) case which we now consider.

The Fuchsian group  $\Gamma$  corresponding to a surface of type (0; 4) is a free group on three generators with the presentation  $\langle C_1, C_2, C_3, C_4; C_4C_3C_2C_1 = 1 \rangle$ . The axis of the transformation  $C_2C_1 = (C_4C_3)^{-1}$  projects onto a simple closed geodesic. It divides the surface into two surfaces of type (0; 3), each truncated along the geodesic of one funnel. We can express this group theoretically by writing  $\Gamma = \Gamma_1 * \Gamma_2 \{am H\}$  where  $\Gamma_1 = \langle C_1, C_2 \rangle$ ,  $\Gamma_2 = \langle C_3, C_4 \rangle$  and  $H = \langle C_2C_1 = (C_4C_3)^{-1} \rangle$ .

We want to determine moduli for our space  $T(S)$  via the construction of a fundamental polygon as we did in the previous cases. We can construct a fundamental polygon for each of the groups  $\Gamma_1$  and  $\Gamma_2$  using the method described in the previous section.

Given the moduli  $k_1, k_2, k_{12}$  and  $k_3, k_4, k_{34} = k_{12}$ , we can construct two normalized groups  $\Gamma_1$  and  $\Gamma'_2$ . For a surface of type (0; 4),  $d = 6$ . The constructions of  $\Gamma_1$  and  $\Gamma'_2$  use five parameters; the sixth will arise in the amalgamation process.

Let us assume that  $\Gamma_1$  has been normalized so that the imaginary axis directed toward 0 is the axis of  $C_2C_1$  and that  $+1$  is the repelling fixed point of  $C_2$ .  $C_1$  will have both its fixed points greater than  $+1$ , with the smaller the attracting fixed point.

The group,  $\Gamma$ , we wish to construct is to contain  $\Gamma_1$  and  $\Gamma_2$  as subgroups. Therefore, normalizing  $C_1$  and  $C_2$  as above determines the rest of the elements of  $\Gamma$  uniquely. In particular, we no longer have the freedom to normalize  $\Gamma_2$ . In  $\Gamma$ ,  $C_2C_1 = (C_4C_3)^{-1}$ ; hence the axis of  $C_4C_3$  must also be the imaginary axis but with  $i\infty$  as the attracting fixed point. Since any curve on the underlying (0; 4) surface which joins the projections of  $h_{C_2}$  and  $h_{C_3}$  must intersect the projection of  $h_{C_2C_1}$ , the fixed points of  $C_3$  must be negative. Let  $\tau$  be the attracting fixed point of  $C_3$ .

We renormalize  $\Gamma'_2$  to obtain  $\Gamma_2$  using the above conditions. Having done this, we can draw the polygon illustrated in Figure 3.  $q$  is the intersection point of the axes of  $C_3C_4^{-1}$  and  $C_4^{-1}C_3$ ,  $q_1 = C_4(q)$  and  $q_2 = C_3^{-1}(q)$ . Again the conditions of Poincaré's theorem are satisfied, and by the Klein-Maskit combination theorem [17] the group generated by the transformations identifying the sides of the polygon is Fuchsian and is, in fact,  $\Gamma$ .

Since the above construction would work equally well for any arbitrarily chosen negative number  $\tau$ ,  $\tau$  can be taken as the sixth parameter for our Teichmüller space.

$\tau$ , however, is not a trace and hence isn't "natural". We would like to find an element of  $\Gamma$  whose trace would determine  $\tau$  uniquely. We have decomposed  $\Gamma$  arbitrarily in some sense. We could as well have decomposed it into

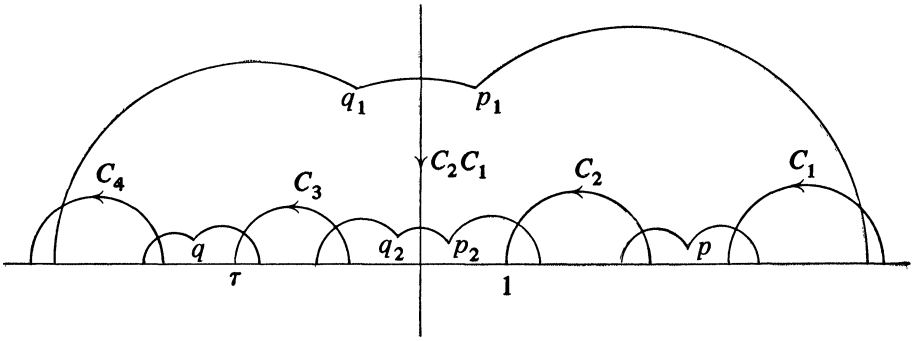

FIGURE 3

$\Gamma'_1 = \langle C_1, C_4 \rangle$ ,  $\Gamma'_2 = \langle C_2, C_3 \rangle$  with  $H' = \langle (C_1 C_4)^{-1} = C_3 C_2 \rangle$ . Mimicking the above construction of  $\Gamma$  in terms of these new groups, we see that trace  $C_3 C_2 = k_{23}$  enters where trace  $C_2 C_1$  did before. We can compute  $k_{23}$  in terms of  $\tau$  and try to solve. Unfortunately, the resulting equation is quadratic in  $\tau$  (see [12]). A geometric interpretation of the existence of two solutions is given in Remark 4.1. A third natural decomposition is  $\Gamma'' = \langle C_1, C_3 \rangle$ ,  $\Gamma''_2 = \langle C_3 C_2 C_3^{-1}, C_4 \rangle$  with  $H'' = \langle C_3 C_1 = C_3 C_2^{-1} C_3^{-1} C_4^{-1} \rangle$ , and a fourth is  $\Gamma''' = \langle C_2, C_4 \rangle$ ,  $\Gamma'''_2 = \langle C_2^{-1} C_3 C_2, C_1 \rangle$  with  $H''' = \langle C_4 C_2 = C_1^{-1} C_2^{-1} C_3^{-1} C_2 \rangle$ . We can compute trace  $C_3 C_1 = k_{13}$  and trace  $C_4 C_2 = k_{24}$  in terms of  $\tau$ . We have

$$C_1 = \begin{pmatrix} (2k_1 + k_2 K_{12} + k_{12} J)/4 & -(K_2 + J)(k_{12} - K_{12})/4 \\ -(k_{12} + K_{12})(K_2 - J)/4 & (2k_1 - k_2 K_{12} - k_{12} J)/4 \end{pmatrix}$$

$$C_2 = \begin{pmatrix} (k_2 - J)/2 & (K_2 + J)/2 \\ (K_2 - J)/2 & (k_2 + J)/2 \end{pmatrix},$$

$$C_2 C_1 = \begin{pmatrix} (k_{12} + K_{12})/2 & 0 \\ 0 & (k_{12} - K_{12})/2 \end{pmatrix},$$

$$C_3 = \begin{pmatrix} (k_3 + \tilde{J})/2 & (K_3 - \tilde{J})\tau/2 \\ (K_3 + \tilde{J})/2\tau & (k_3 - \tilde{J})/2 \end{pmatrix},$$

$$C_4 = \begin{pmatrix} (2k_4 - k_3 K_{12} - k_{12} \tilde{J})/4 & -(K_3 - \tilde{J})(k_{12} - K_{12})\tau/4 \\ -(K_3 + \tilde{J})(k_{12} + K_{12})/4\tau & (2k_4 + k_3 K_{12} + k_{12} \tilde{J})/4 \end{pmatrix},$$

where  $k_i < -2$ ,  $i = 1, 2, 3, 4$ ,  $k_{12} < -2$ ,  $K_i = \sqrt{k_i^2 - 4}$ ,  $J = (2k_1 - k_2 k_{12})/K_{12}$ ,  $\tilde{J} = (2k_4 - k_3 k_{12})/K_{12}$ . Therefore,

$$k_{23} = \frac{1}{4} \{ k_2 k_3 - J\tilde{J} + (\tau + \tau^{-1})(K_2 K_3 + J\tilde{J}) - (\tau - \tau^{-1})(\tilde{J} K_2 + J K_3) \},$$

$$k_{13} = \frac{1}{2} (k_1 k_3 + k_2 k_4) + (k_{12}/4)(J\tilde{J} - k_2 k_3)$$

$$- \frac{1}{8} (\tau + \tau^{-1}) \{ k_{12}(K_2 K_3 + J\tilde{J}) - K_{12}(\tilde{J} K_2 + J K_3) \}$$

$$+ \frac{1}{8} (\tau - \tau^{-1}) \{ k_{12}(\tilde{J} K_3 + J K_{12}) - K_{12}(K_2 K_3 + J\tilde{J}) \},$$

$$\begin{aligned}
 k_{24} = & \frac{1}{2}(k_1k_3 + k_2k_4) + (k_{12}/4)(J\tilde{J} - k_2k_3) \\
 & - \frac{1}{8}(\tau + \tau^{-1})\{K_{12}(K_2K_3 + J\tilde{J}) + k_{12}(\tilde{J}K_2 + JK_3)\} \\
 & + \frac{1}{8}(\tau - \tau^{-1})\{K_{12}(K_2K_3 + J\tilde{J}) + k_{12}(\tilde{J}K_3 + JK_2)\}.
 \end{aligned}$$

From these equations we have

$$(4.1) \quad k_{13} + k_{24} = k_1k_3 + k_2k_4 - k_{12}k_{23}$$

and

$$(4.2) \quad \begin{aligned}
 & k_{12}^2 + k_{23}^2 + k_{13}^2 + k_{12}k_{23}k_{12} - k_{12}(k_1k_2 + k_3k_4) - k_{13}(k_1k_3 + k_2k_4) \\
 & - k_{23}(k_2k_3 + k_1k_4) + k_1^2 + k_2^2 + k_3^2 + k_4^2 + k_1k_2k_3k_4 - 4 = 0.
 \end{aligned}$$

Note that these equations are invariant under cyclic permutation of the indices.

Let us set

$$\begin{aligned}
 \xi &= -k_{12}, \quad \eta = -k_{23}, \quad \zeta = -k_{13}, \quad \zeta' = -k_{24}, \\
 J_1 &= k_1k_2 + k_3k_4, \quad J_2 = k_2k_3 + k_1k_4, \quad J_3 = k_1k_3 + k_2k_4, \\
 J_4 &= k_1^2 + k_2^2 + k_3^2 + k_4^2 + k_1k_2k_3k_4 - 4.
 \end{aligned}$$

Note that  $J_i \geq 8, i = 1, 2, 3,$  and  $J_4 > 28.$  Equation (4.1) becomes

$$(4.1)' \quad \zeta + \zeta' = \xi\eta - J_3,$$

and equation (4.2) becomes

$$(4.2)' \quad \xi^2 + \eta^2 + \zeta^2 - \xi\eta\zeta + J_1\xi + J_2\eta + J_3\zeta + J_4 = 0.$$

For fixed  $k_1, k_2, k_3, k_4$  (4.2)' describes a 2-dimensional surface  $\mathfrak{M} = \mathfrak{M}(k_1, k_2, k_3, k_4)$  in the Euclidean space determined by the rectangular coordinates  $\xi, \eta, \zeta.$  Combining these results and those in [9]–[12], we have

**THEOREM 4.1.** *The Teichmüller space  $T(S)$  of surfaces of type (0; 4) is described by the six manifold  $\mathfrak{M} \times \mathbf{R}^4$  in  $\mathbf{R}^7,$  where  $\mathbf{R}^4$  is given by  $(k_1, k_2, k_3, k_4), k_i < -2,$  and  $\mathfrak{M}$  is the surface  $\mathfrak{M}(k_1, k_2, k_3, k_4)$  determined by equation (4.2)' above.*

**PROOF.** Given the coordinates  $(k_1, k_2, k_3, k_4, \xi, \eta, \zeta)$  we have described above an explicit construction for the marked group  $\Gamma.$  That is, we can explicitly write down generating transformations as identifying transformations of the sides of a nondegenerate non-Euclidean polygon. This polygon, with its sides identified, corresponds to a marked surface of type (0; 4). On the other hand, we have proved [9] that every marked surface of type (0; 4) admits a canonical modular polygon of this type. From the polygon we can read off the coordinates.

**REMARK 4.1.** Note that in the above development we singled out  $\zeta = k_{13}$  over  $\zeta' = k_{24}$  in equation (4.2)'. Suppose we consider a surface corresponding to a point  $(k_1, k_2, k_3, k_4, \xi, \eta, \zeta)$  and let  $\Gamma$  be the normalized Fuchsian group corresponding to it. Let  $R$  be the mapping of  $U$  which is the reflection in the imaginary axis ( $x + iy \rightarrow -x + iy$ ), and form a new group  $\Gamma' = R\Gamma R^{-1}.$  This reflection induces an orientation reversing self-map of the underlying surface. Now let  $T$  be the linear functional transformation which sends  $0, \infty$



into themselves and sends the image of the reflected attracting fixed point of  $C_3$  to  $+1$ . If  $\tilde{\Gamma} = TR\Gamma R^{-1}T^{-1}$ ,  $\tilde{\Gamma}$  is properly normalized and its coordinates  $(\tilde{k}_1, \tilde{k}_2, \tilde{k}_3, \tilde{k}_4, \tilde{\xi}, \tilde{\eta}, \tilde{\zeta})$  satisfy  $\tilde{k}_1 = k_4, \tilde{k}_2 = k_3, \tilde{k}_3 = k_2, \tilde{k}_4 = k_1, \tilde{J}_1 = J_1, \tilde{J}_2 = J_2, \tilde{J}_3 = J_3, \tilde{J}_4 = J_4$  and  $\tilde{\xi} = \xi, \tilde{\eta} = \eta, \tilde{\zeta} = \zeta'$ .

Call the mapping  $R$  induces on Teichmüller space  $R$  also, and call points  $t, t' \in T$  with  $t' = R(t)$  conjugate points. From the above equations we see that  $R$  leaves each surface  $\mathfrak{M}$  invariant. In the construction above, the expression for  $k_{23}$  was quadratic in  $\tau$ ; the two solutions correspond to conjugate points. Since  $R$  is an orientation reversing involution,  $R$  does not belong to the mapping class group.

4B. Our next task is to study the mapping class group for surfaces of type  $(0; 4)$ . Suppose a representative basis for the marking of  $\Gamma$  is  $\mathfrak{S} = \{\gamma_1, \gamma_2, \gamma_3, \gamma_4; \gamma_1\gamma_2\gamma_3\gamma_4 \sim 1\}$  and  $\gamma_i$  is freely homotopic to the projection of  $h_{C_i}$ . Let  $\sigma_i$  be the Dehn twist about  $\gamma_1\gamma_2$ ,  $\sigma_2$  the Dehn twist about  $\gamma_2\gamma_3$  and  $\sigma_3$  the Dehn twist about  $\gamma_3\gamma_4$ . Then

$$\begin{aligned} \sigma_1: \gamma_1 &\rightarrow \gamma_2, & \gamma_2 &\rightarrow \gamma_2^{-1}\gamma_1\gamma_2, & \gamma_3 &\rightarrow \gamma_3, & \gamma_4 &\rightarrow \gamma_4, \\ \sigma_2: \gamma_1 &\rightarrow \gamma_1, & \gamma_2 &\rightarrow \gamma_3, & \gamma_3 &\rightarrow \gamma_3^{-1}\gamma_2\gamma_3, & \gamma_4 &\rightarrow \gamma_4, \\ \sigma_3: \gamma_1 &\rightarrow \gamma_1, & \gamma_2 &\rightarrow \gamma_2, & \gamma_3 &\rightarrow \gamma_4, & \gamma_4 &\rightarrow \gamma_4^{-1}\gamma_3\gamma_4. \end{aligned}$$

We have

**THEOREM 4.2.** *The mapping class group  $M$  for surfaces of type  $(0; 4)$  admits a presentation with the Dehn twists  $\sigma_1, \sigma_2, \sigma_3$  as generators and  $\sigma_1\sigma_3 = \sigma_3\sigma_1, \sigma_1\sigma_2\sigma_1 = \sigma_2\sigma_1\sigma_2, \sigma_2\sigma_3\sigma_2 = \sigma_3\sigma_2\sigma_3, \sigma_1\sigma_2\sigma_3^2\sigma_2\sigma_1 = 1$  and  $(\sigma_1\sigma_2\sigma_3)^4 = 1$  as defining relations.*

**PROOF.** (See [16, p. 156], [5, p. 155].) We can derive another presentation from this one in which the generators are no longer simple Dehn twists but are more suitable for our purposes. Using the relations repeatedly we can show  $(\sigma_1\sigma_2\sigma_3)^4 = (\sigma_1\sigma_2\sigma_3^2\sigma_2\sigma_1)(\sigma_3\sigma_2)^3$  and, hence,  $(\sigma_3\sigma_2)^3 = 1$ . Similarly,  $(\sigma_2\sigma_3)^3 = (\sigma_1\sigma_2)^3 = (\sigma_2\sigma_1)^3 = 1$ . Let  $\tau = \sigma_1\sigma_2\sigma_3$  ( $\tau^{-1} = \sigma_3\sigma_2\sigma_1$ ) and  $\sigma = \sigma_3\sigma_2$ . It is easy to check that  $\sigma$  and  $\tau$  generate  $M$  and satisfy defining relations  $\sigma^3 = 1, \tau^4 = 1$ .

We compute the action of  $\sigma$  and  $\tau$  on the curves of the basis  $\mathfrak{S}$ , and their products.

$$\begin{aligned} \sigma: \gamma_1 &\rightarrow \gamma_1, & \gamma_2 &\rightarrow \gamma_3, & \gamma_3 &\rightarrow \gamma_4, & \gamma_4 &\rightarrow (\gamma_3\gamma_4)^{-1}\gamma_2\gamma_3\gamma_4 \sim \gamma_1\gamma_2\gamma_1^{-1}, \\ & \gamma_1\gamma_2 &\rightarrow \gamma_1\gamma_3, & \gamma_2\gamma_3 &\rightarrow \gamma_3\gamma_4 \sim (\gamma_1\gamma_2)^{-1}, & \gamma_1\gamma_3 &\rightarrow \gamma_1\gamma_4 \sim \gamma_1(\gamma_2\gamma_3)^{-1}\gamma_1^{-1}, \\ & \gamma_2\gamma_4 &\rightarrow \gamma_3\gamma_1\gamma_2\gamma_1^{-1}. \\ \tau: \gamma_1 &\rightarrow \gamma_4, & \gamma_2 &\rightarrow \gamma_4^{-1}\gamma_1\gamma_4, & \gamma_3 &\rightarrow \gamma_4^{-1}\gamma_2\gamma_4, & \gamma_4 &\rightarrow \gamma_4^{-1}\gamma_3\gamma_4, \\ & \gamma_1\gamma_2 &\rightarrow \gamma_1\gamma_4 \sim \gamma_1(\gamma_2\gamma_3)^{-1}\gamma_1^{-1}, & \gamma_2\gamma_3 &\rightarrow \gamma_4^{-1}\gamma_1\gamma_2\gamma_4, & \gamma_1\gamma_3 &\rightarrow \gamma_2\gamma_4, \\ & \gamma_2\gamma_4 &\rightarrow \gamma_4^{-1}\gamma_1\gamma_3\gamma_4. \end{aligned}$$

Call the induced mapping of the moduli of Theorem 4.1,  $S$  and  $T$ , respectively. Then

$$\begin{aligned} S: k_1 &\rightarrow k_1, & k_2 &\rightarrow k_3, & k_3 &\rightarrow k_4, & k_4 &\rightarrow k_2, & k_{12} &\rightarrow k_{13}, \\ k_{23} &\rightarrow k_{12}, & k_{13} &\rightarrow k_{23}, & k_{24} &\rightarrow k_2k_3 + k_1k_4 - k_{12}k_{13} - k_{23}, \\ \xi &\rightarrow \zeta, & \eta &\rightarrow \xi, & \zeta &\rightarrow \eta, & \zeta' &\rightarrow \xi\zeta - \eta - J_2, \end{aligned}$$

$$\begin{aligned}
J_1 &= k_1k_2 + k_3k_4 \rightarrow k_1k_3 + k_4k_2 = J_3, \\
J_2 &= k_2k_3 + k_1k_4 \rightarrow k_3k_4 + k_1k_2 = J_1, \\
J_3 &= k_1k_3 + k_2k_4 \rightarrow k_1k_4 + k_3k_2 = J_2, \\
J_4 &= k_1^2 + k_2^2 + k_3^2 + k_4^2 + k_1k_2k_3k_4 - 4 \\
&\rightarrow k_1^2 + k_2^2 + k_3^2 + k_4^2 + k_1k_2k_3k_4 - 4 = J_4,
\end{aligned}$$

$$\begin{aligned}
T: k_1 &\rightarrow k_4, k_2 \rightarrow k_1, k_3 \rightarrow k_2, k_4 \rightarrow k_3, \\
k_{12} &\rightarrow k_{23}, k_{23} \rightarrow k_{12}, k_{13} \rightarrow k_{24}, k_{24} \rightarrow k_{13}, \\
\xi &\rightarrow \eta, \eta \rightarrow \xi, \zeta \rightarrow \zeta', \zeta' \rightarrow \zeta, \\
J_1 &\rightarrow J_2, J_2 \rightarrow J_1, J_3 \rightarrow J_3, J_4 \rightarrow J_4.
\end{aligned}$$

$S$  and  $T$  satisfy the relations  $S^3 = 1$  and  $T^4 = 1$ . We write out for future use the element of infinite order,  $S^{-1}T^{-1}$ :

$$\begin{aligned}
S^{-1}T^{-1}: k_1 &\rightarrow k_2, k_2 \rightarrow k_1, k_3 \rightarrow k_3, k_4 \rightarrow k_4, \\
\xi &\rightarrow \xi, \eta \rightarrow \zeta', \zeta \rightarrow \eta, \zeta' \rightarrow \xi\zeta' - \eta - J_2, \\
J_1 &\rightarrow J_1, J_2 \rightarrow J_3, J_3 \rightarrow J_2, J_4 \rightarrow J_4.
\end{aligned}$$

We consider the action of these maps on the 7-tuple  $(k_1, k_2, k_3, k_4, \xi, \eta, \zeta)$ . Each map permutes the coordinates  $(k_1, k_2, k_3, k_4)$  and sends the point  $(\xi, \eta, \zeta)$  on the surface  $\mathfrak{M}(k_1, k_2, k_3, k_4)$  into another point on the *same* surface. This is analogous to the situation we encountered in §3, and we proceed to pursue this analogy further. Consider those points of  $\mathfrak{M}$  left fixed by  $T$ ; they lie on the curve defined by  $\xi\eta - 2\zeta - J_3 = 0$ . Call this curve  $K_3$ . The curve  $S(K_3) = K_1$  on  $\mathfrak{M}$  is defined by  $\eta\zeta - 2\xi - J_1 = 0$  and is left fixed by  $STS^{-1}$ ; the curve  $S^{-1}(K_3) = K_2$  on  $\mathfrak{M}$  is defined by  $\xi\zeta - 2\eta - J_2 = 0$  and is left fixed by  $S^{-1}TS$ . Assuming any two of these curves intersect leads to a contradiction since  $\xi, \eta, \zeta', J_i, i = 1, 2, 3, 4$ , are all positive. Moreover, the region  $\Delta$  of  $\mathfrak{M}$  bounded by  $K_1, K_2$  and  $K_3$  is simply connected and defined by  $\eta\zeta - 2\xi - J_1 > 0, \xi\zeta - 2\eta - J_2 > 0$  and  $\xi\eta - 2\zeta - J_3 > 0$ . The curves  $\xi = \eta, \eta = \zeta, \xi = \zeta$  don't play quite the same role as they did before. However, we compute that  $\xi = \eta$  intersects only  $K_3, \eta = \zeta$  intersects only  $K_1, \xi = \zeta$  intersects only  $K_2$  and that the three intersect in a point inside  $\Delta$ . Figure 4 shows a schematic representation of  $\mathfrak{M}$  on which  $\Delta$  is shaded.

The curve  $\xi = 2\lambda$  is a hyperbola on  $\mathfrak{M}$  given by the equation

$$\eta^2 - 2\lambda\eta\zeta + \zeta^2 + J_2\eta + J_3\zeta + 4\lambda^2 + 2\lambda J_1 + J_4 = 0.$$

$\eta$  attains its minimum value  $\eta_0(\lambda) = (J_3\lambda + J_2)/2(\lambda^2 - 1)$  at  $2\lambda\zeta - 2\eta - J_2 = 0$  and  $\zeta$  attains its minimum value  $\zeta_0(\lambda) = (J_2\lambda + J_3)/2(\lambda^2 - 1)$  at  $2\lambda\eta - 2\zeta - J_3 = 0$ . The segment  $H_\lambda^0$  of  $H_\lambda$  between  $(\eta_0, \zeta(\eta_0))$  and  $(\eta(\zeta_0), \zeta_0)$  is called the *minimal segment* of  $H_\lambda$ .

The curve  $\eta = \zeta$  intersects  $H_\lambda$  once and the intersection point is in the minimal segment. If  $2\lambda < \eta_0$ ,  $H_\lambda$  doesn't intersect the curve  $\xi = \eta$  at all. Similarly, if  $2\lambda < \zeta_0$ ,  $H_\lambda$  doesn't intersect the curve  $\xi = \zeta$ . If  $2\lambda = \eta_0$ ,  $H_\lambda$  and  $\xi = \eta$  have exactly one common point and they are tangent to each other at that point. If  $2\lambda > \eta_0$ ,  $H_\lambda$  and  $\xi = \eta$  intersect in two points. Similarly, if  $2\lambda = \zeta_0$ ,  $H_\lambda$  and  $\xi = \zeta$  have one common point where they are tangent, and if  $2\lambda > \zeta_0$  they have two common points.

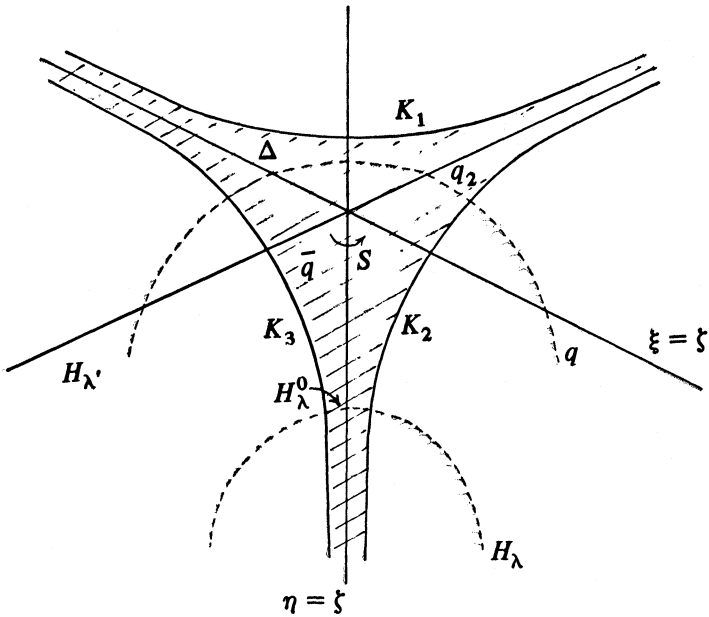

FIGURE 4

LEMMA 4.1. Let  $q = (k_1, k_2, k_3, k_4, \xi, \eta, \zeta)$  be the coordinates of a marked surface of type  $(0; 4)$ . Let  $\mathfrak{M} = \mathfrak{M}(k_1, k_2, k_3, k_4)$  be the surface defined by equation (4.2)'. Then there is a marked surface of type  $(0; 4)$  with coordinates  $\bar{q} = (\bar{k}_1, \bar{k}_2, \bar{k}_3, \bar{k}_4, \bar{\xi}', \bar{\eta}, \bar{\zeta})$  equivalent to  $q$  such that  $(\bar{k}_1, \bar{k}_2, \bar{k}_3, \bar{k}_4)$  is a permutation of  $(k_1, k_2, k_3, k_4)$  and  $(\bar{\xi}, \bar{\eta}, \bar{\zeta})$  is a point on the surface  $\mathfrak{M}(k_1, k_2, k_3, k_4)$  such that  $\bar{\xi} < \bar{\eta}, \bar{\xi} < \bar{\zeta}, \bar{\xi}\bar{\zeta} - 2\bar{\eta} - J_2 > 0$  and  $\bar{\xi}\bar{\eta} - 2\bar{\zeta} - J_3 > 0$ .

PROOF. The transformation  $S$  changes the ordering of the 4-tuple  $(k_1, k_2, k_3, k_4)$  and sends the surface  $\mathfrak{M}$  into itself permuting the coordinates  $(\xi, \eta, \zeta)$ . It also permutes the curves  $\eta\zeta - 2\xi - J_1 = 0, \xi\eta - 2\zeta - J_3 = 0$  and  $\xi\zeta - 2\eta - J_2 = 0$  and sends the region  $\Delta$  bounded by them into itself.

Applying  $S$  or  $S^{-1}$  if necessary to our point  $q$ , we may assume that  $\xi < \eta, \xi < \zeta$ . Only one of the inequalities (i)  $\xi\zeta - 2\eta - J_2 > 0$ , (ii)  $\xi\eta - 2\zeta - J_3 > 0$  can fail to hold for  $q$ . Assume the latter does not hold. These conditions on  $q$  imply also that  $\eta < \zeta$ . As a first step in obtaining  $\bar{q}$  from  $q$ , set  $q^1 = S^{-1}T^{-1}(q) = (\dots, \xi^1, \eta^1, \zeta^1)$ , where  $\xi^1 = \xi, \eta^1 = \xi\eta - \zeta - J_3 = \zeta', \zeta^1 = \eta, J_1^1 = J_1, J_2^1 = J_3, J_3^1 = J_2$ . The above inequalities and remarks imply the coordinates of  $q^1$  satisfy  $\xi^1 < \zeta, \eta^1 < \zeta, \xi < \zeta' < \zeta$ ,

(i) 
$$\xi^1\zeta^1 - 2\eta^1 - J_2^1 = -\xi\eta + 2\zeta + J_3 > 0.$$

The point  $q_1$  again lies on the hyperbola  $H_{\xi/2}$ . It is either in the minimal segment  $H_{\xi/2}^0$  or in the same component of the complement of the minimal segment as  $q$  and situated between  $q$  and the minimal segment. If  $q_1$  is not in the minimal segment,  $\xi^1\eta^1 - 2\zeta^1 - J_3^1 < 0$ , and we set  $q_2 = S^{-1}T^{-1}(q_1)$ .  $q_2$  is either in the minimal segment or closer to it than  $q_1$ . We define recursively,  $q_n = S^{-1}T^{-1}(q_{n-1})$ . Since these points  $q_n$  are all congruent under the modular group, and since the modular group acts discontinuously, the points  $q_n$

cannot accumulate. Hence for some  $N$ ,  $q_N$  lies in the minimal segment. Apply  $S$  or  $S^{-1}$  to  $q_N$  if necessary to obtain the desired  $\bar{q}$  (see Figure 4). Q.E.D.

Let us now recall the reflection transformation  $R$  which we defined in Remark 4.1. Let  $F$  be the group generated by  $R$ ,  $S$  and  $T$ . Since  $R$  induces an orientation reversing homeomorphism of the underlying marked Riemann surface, the group  $F$  is a representation of the group of *all* homeomorphisms, orientation preserving and reversing, of the underlying surface.  $F$  acts discontinuously on the Teichmüller space  $T(S)$ . We verify that the following relations hold in  $F$ :  $R^2 = S^3 = T^4 = 1$ ,  $RT^3 = TR$ ,  $STR = RTS^{-1}$ .

$M$  is a subgroup of index 2 in  $F$ . Therefore we will first construct a fundamental domain  $\Delta^*$  for  $F$  acting on  $T(S)$  and obtain a fundamental domain for  $M$  acting on  $T(S)$  by forming  $\Delta^* \cup R(\Delta^*)$ .

**THEOREM 4.3.** *A fundamental domain  $\Delta^*$  for  $F$ , acting on  $T(S)$ , is defined by the inequalities  $k_1 \leq k_2 \leq k_3 \leq k_4$  in  $\mathbf{R}^4$ , and the inequalities  $\xi\eta - 2\zeta - J_3 \geq 0$ ,  $\xi\zeta - 2\eta - J_2 \geq 0$  and  $\eta\zeta - 2\xi - J_1 \geq 0$  on the corresponding surfaces  $\mathfrak{N}(k_1, k_2, k_3, k_4)$ .*

**PROOF.** Consider the transformation  $RTS$  in  $F$ :

$$\begin{aligned} RTS: k_1 &\rightarrow k_4, & k_2 &\rightarrow k_3, & k_3 &\rightarrow k_1, & k_4 &\rightarrow k_2, \\ \xi &\rightarrow \xi, & \eta &\rightarrow \zeta, & \zeta &\rightarrow \eta, & \zeta' &\rightarrow \xi\zeta - \eta - J_2, \\ J_1 &\rightarrow J_1, & J_2 &\rightarrow J_3, & J_3 &\rightarrow J_2, & J_4 &\rightarrow J_4. \end{aligned}$$

Using Lemma 4.2 and the transformation  $RTS$  if necessary, we can find, given an arbitrary point  $\bar{q} \in T(S)$ , a point  $q$  congruent under the group  $F$  to  $\bar{q}$  such that the coordinates  $(\xi, \eta, \zeta)$  of  $q$  satisfy

$$\xi \leq \eta \leq \zeta, \quad \xi\eta - 2\zeta - J_3 \geq 0,$$

and the coordinates  $(k_1, k_2, k_3, k_4)$  are some permutation of the coordinates  $(\bar{k}_1, \bar{k}_2, \bar{k}_3, \bar{k}_4)$  of  $\bar{q}$ .

This region  $\Delta_0$ , defined by  $\xi \leq \eta \leq \zeta$  and  $\xi\eta - 2\zeta - J_3 \geq 0$ , on the surface  $\mathfrak{N}(k_1, k_2, k_3, k_4)$  is one sixth of the domain  $\Delta$  defined above; that is,

$$\Delta = [\Delta_0 \cup S(\Delta_0) \cup S^2(\Delta_0) \cup RTS(\Delta_0) \cup RTS^2(\Delta_0) \cup RT(\Delta_0)].$$

We must also consider restrictions on the  $(k_1, k_2, k_3, k_4)$  coordinates in the construction of a fundamental domain since they undergo permutation under the various mapping elements. To this end we remark that the maps  $T^2$ ,  $ST^2S^2$  and  $S^2T^2S$  leave  $(\xi, \eta, \zeta)$  fixed and yield a permutation of  $(k_1, k_2, k_3, k_4)$  of order 2. From among these images of  $q$  we choose the 4-tuple with smallest first entry  $(k_1^0, k_2, k_3, k_4)$ ;  $S$  and  $S^2$  permute the last three coordinates cyclically and we may choose that 4-tuple and its corresponding point in  $\Delta$  with smallest second coordinate:  $(k_1^0, k_2^0, k_3, k_4)$ . If  $k_3 \leq k_4$  we have described  $\Delta^*$ ; if not, the map  $T^2RTS$  interchanges the coordinates  $k_3$  and  $k_4$ , and since  $T^2$  doesn't affect the  $(\xi, \eta, \zeta)$  coordinates,  $T^2RTS$  sends these into  $(\xi, \zeta, \eta)$ . Therefore given any point  $\bar{q}$  we can find a congruent point in the region  $\Delta^*$ . This completes the first half of the proof.

To finish the proof that  $\Delta^*$  is a fundamental domain for  $F$ , we must show that if  $W$  is any word in  $F$ , not equal to the identity, and if  $\mathring{\Delta}^*$  is the interior of  $\Delta^*$ , then  $W(\mathring{\Delta}^*) \cap \mathring{\Delta}^* = \emptyset$ . We first note that since any word  $W$  acts at

most by permutation on the coordinates  $(k_1, k_2, k_3, k_4)$  of any point  $q$  in  $\mathring{\Delta}^*$ , and the conditions defining  $\mathring{\Delta}^*$  completely determine the order of these coordinates, it will suffice to prove that  $W(\mathring{\Delta}_0) \cap \mathring{\Delta}_0 = \emptyset$ , where  $\mathring{\Delta}_0$  is the interior of  $\Delta_0$ . Next we note that  $\mathring{\Delta}_0$  is a domain on the surface  $\mathfrak{N}$  and that the element  $T^2$  of  $F$ , while permuting the coordinates  $(k_1, k_2, k_3, k_4)$  of a point  $q$ , acts as the identity on the coordinates  $(\xi, \eta, \zeta)$  and, hence, also on the surface  $\mathfrak{N}$ . We therefore consider the group  $\tilde{F} = F/\langle T^2 \rangle$  which is a group of self-mappings of the surface  $\mathfrak{N}$  and agrees with the action of  $F$  on the surface  $\mathfrak{N}$ . Hence it will suffice to prove that for  $\tilde{W}$ , any nontrivial word in  $\tilde{F}$ ,  $\tilde{W}(\mathring{\Delta}_0) \cap \mathring{\Delta}_0 = \emptyset$ .

$\tilde{F}$  is generated by  $\tilde{R}, \tilde{S}$  and  $\tilde{T}$ , the images of  $R, S$  and  $T$  of  $F$  under the quotient mapping. The relations these generators satisfy are  $\tilde{S}^3 = \tilde{T}^2 = \tilde{R}^2 = 1, \tilde{R}\tilde{T} = \tilde{T}\tilde{R}, (\tilde{R}\tilde{T}\tilde{S})^2 = 1$ . It will, however, be more convenient to consider the following set of generators for  $\tilde{F}$ :  $R_1 = \tilde{R}, R_2 = \tilde{R}\tilde{T}\tilde{S}, R_3 = \tilde{R}\tilde{T}$ ; they satisfy the relations  $R_1^2 = R_2^2 = R_3^2 = 1$ .

Now consider the region  $\Delta_0$  and let  $\tilde{W}$  be a word in the generators  $R_1, R_2, R_3$ . Each  $R_i(\Delta_0), i = 1, 2, 3$ , is a reflection of  $\Delta_0$  in one of its sides. Suppose there were a point  $q \in \mathring{\Delta}_0 \cap \tilde{W}(\mathring{\Delta}_0)$ . Associate a closed path  $\gamma$  on  $\mathfrak{N}$  to  $Q$  as follows: if  $R_{i_1}$  is the first letter of  $\tilde{W}$  (reading from right to left) we join  $q$  to a point  $q_1$  in  $R_{i_1}(\Delta_0) = \Delta_1$  by a path on  $\mathfrak{N}$  which crosses the side of  $\Delta_0$  left fixed by  $R_{i_1}$ . The next letter  $R_{i_2}$  of  $\tilde{W}$  determines a reflection in one of the sides of  $\Delta_1$ ; set  $\Delta_2 = R_{i_2}(\Delta_1)$  and join  $q_1$  to a point  $q_2$  in  $\Delta_2$  by a path which crosses the side of  $\Delta_1$  left fixed by  $R_{i_2}$ . We continue this procedure for each letter of  $\tilde{W}$  until we arrive at a region  $\Delta_n$  such that  $q \in \Delta_n$ . We join  $q_{n-1}$  to  $q_n = q$  by a path crossing the common side of  $\Delta_{n-1}$  and  $\Delta_n$ . We propose to show that  $\Delta_n = \Delta_0$  and, hence, that  $\tilde{W}$  is the identity. This will complete the proof.

The generators of  $\tilde{F}$  are all involutions of  $\mathfrak{N}$ . The generators  $R_2$  and  $R_3$  are reflections of  $\mathfrak{N}$  in the planes  $\eta = \zeta$  and  $\xi = \eta$ , respectively. The vertex,  $\xi = \eta = \zeta$ , of  $\Delta_0$  is a fixed point of the element  $R_3R_2$  which satisfies  $(R_3R_2)^3 = 1$ . To see how the involution  $R_1$  acts on  $\mathfrak{N}$  we consider the intersection of the plane  $\xi = 2\lambda$  with the surface  $\mathfrak{N}$ . This is a hyperbola  $H_\lambda$  given by

$$\eta^2 - 2\lambda\eta\zeta + \zeta^2 + J_2\eta + J_3\zeta + (2J\lambda + J_4 + 4\lambda^2) = 0$$

on  $\mathfrak{N}$ . Except for the point  $(\eta, (2\lambda\eta - J_2)/2)$  there are two points on  $H_\lambda$  for each value of  $\eta$ .  $R_1$  leaves the point  $(\eta, (2\lambda\eta - J_2)/2)$  fixed and interchanges the pair of corresponding points of  $H_\lambda$  for every other value of  $\eta$ . As  $\xi$  varies, these fixed points define a curve  $\xi\eta - 2\zeta - J_2 = 0$  on  $\mathfrak{N}$  which is left pointwise fixed by  $R_1$ . The reflections in the planes send their fixed curves into one another as do the reflections in the hyperbolas.

$\Delta_0$  has two vertices; one where the curves on  $\mathfrak{N}$  defined by  $\xi = \eta$  and  $\eta = \zeta$  intersect and one where  $\xi = \eta$  intersects the curve on  $\mathfrak{N}$  defined by  $2\zeta = \xi\eta - J_2$ . The curve on  $\mathfrak{N}$  defined by  $\xi = \zeta$  passes through the first vertex although it isn't a boundary of  $\Delta_0$ . We see therefore that there are six curves which meet at the first vertex and four which meet at the second.

Consider now these curves and all their images on  $\mathfrak{N}$  under the action of  $\tilde{F}$ . Since all the elements are reflections as described above, the images of the vertices will again be points where six or four curves meet.

Let us look now at the curve  $\gamma$  we have associated to the word  $\tilde{W}$ . The curve is far from unique. The region on  $\mathfrak{M}$  that it bounds is compact though and contains only finitely many images of the vertices. We can put a grid on  $\mathfrak{M}$  small enough so that each vertex is contained in only one square of the grid. Following Poincaré [24], we see that going around  $\gamma$  yields the same word as going around the squares of the grid contained inside  $\gamma$ . However, each square is either totally inside some image of  $\Delta_0$ , crosses one side and returns through that side or goes around a single vertex. It is clear that the transformation associated to each of these possibilities can only be the identity. We conclude that  $\Delta_n = \Delta_0$  and that  $\tilde{W}$  is the identity as required. Q.E.D.

Since we have identified each point in  $T(S)$  with its conjugate, it follows that:

**THEOREM 4.4.** *A fundamental domain for the Teichmüller modular group  $M$  acting on the Teichmüller space of marked surfaces of type  $(0; 4)$  is the domain defined by the inequalities  $k_1 \leq k_2 \leq k_3$ ,  $k_1 \leq k_2 \leq k_4$  in  $\mathbf{R}^4$ , and the inequalities  $\xi\eta - 2\zeta - J_3 \geq 0$ ,  $\xi\zeta - 2\eta - J_2 \geq 0$  and  $\eta\zeta - 2\xi - J_1 \geq 0$  on the corresponding surfaces  $\mathfrak{M}(k_1, k_2, k_3, k_4)$ .*

### 5. Surfaces of type $(2; 0)$ .

5A. We turn now to the next case: the Teichmüller space of surfaces of type  $(2; 0)$ . The Fuchsian group  $\Gamma$  corresponding to such a group is a one relator group on four generators and has the following presentation:

$$\Gamma = \langle A_1, B_1, A_2, B_2; B_2^{-1}A_2^{-1}B_2A_2B_1^{-1}A_1^{-1}B_1A_1 = 1 \rangle.$$

Set  $C = B_1^{-1}A_1^{-1}B_1A_1 = A_2^{-1}B_2^{-1}A_2B_2$ . Since the presentation arises from a canonical basis, the axis  $h_C$  of  $C$  projects onto a simple closed geodesic  $\gamma$  which divides the surface into two tori, each with a hole. As in §4A we express this situation group theoretically by writing  $\Gamma = \Gamma_1 * \Gamma_2 \{am H\}$ , where  $\Gamma_i = \langle A_i, B_i \rangle$ ,  $i = 1, 2$ , and  $H = \langle C \rangle$ .

To determine moduli, we construct normalized fundamental polygons from the traces of  $A_i$ ,  $B_i$ ,  $A_iB_i$  and  $C$  according to the procedure in §3A. Recall, if  $x_i = \text{trace } A_i$ ,  $y_i = \text{trace } B_i$ ,  $z_i = \text{trace } A_iB_i$  and  $\xi = -\text{trace } C$ , then  $x_i^2 + y_i^2 + z_i^2 - x_iy_iz_i - 2 + \xi = 0$ ,  $i = 1, 2$ . We thus have seven parameters and two relations spanning a space of dimension 5. We note, however, that we have normalized both  $\Gamma_1$  and  $\Gamma_2$  and are really only entitled to normalize one of these groups. When we renormalize  $\Gamma_2$  so that  $B_1^{-1}A_1^{-1}B_1A_1 = A_2^{-1}B_2^{-1}A_2B_2$ , we still have one degree of freedom, exactly as we had before in §4A. In fact, we can consider our surface of type  $(2; 0)$  as a surface of type  $(0; 4)$  with the holes identified in pairs. In this regard the role of  $C_1$  is played by  $A_1$ , that of  $C_2$  by  $B_1^{-1}A_1^{-1}B_1$ , that of  $C_3$  by  $A_2$  and that of  $C_4$  by  $B_2^{-1}A_2^{-1}B_2$ . We have  $\xi = |\text{trace } C|$ . We set  $\eta = |\text{trace } A_2B_1^{-1}A_1^{-1}B_1|$ ,  $\zeta = |\text{trace } A_2A_1|$ . We rewrite equation (4.2)' in these terms, and from [11] and [12] we conclude:

**THEOREM 5.1.** *The Teichmüller space  $T(S)$  of surfaces of type  $(2; 0)$  is described by the six-manifold in  $\mathbf{R}^9$  defined by the equations:*

$$(5.1) \quad x_1^2 + y_1^2 + z_1^2 - x_1y_1z_1 + \xi - 2 = 0,$$

$$(5.2) \quad x_2^2 + y_2^2 + z_2^2 - x_2y_2z_2 + \xi - 2 = 0,$$

$$(5.3) \quad \xi^2 + \eta^2 + \zeta^2 - \xi\eta\zeta + (x_1^2 + x_2^2)\xi + 2x_1x_2(\eta + \zeta) + 2x_1^2 + 2x_2^2 + x_1^2x_2^2 - 4 = 0.$$

(In the notation of (4.2)',  $J_1 = x_1^2 + x_2^2$ ,  $J_2 = J_3 = 2x_1x_2$ ,  $J_4 = 2(x_1^2 + x_2^2) + x_1^2x_2^2 - 4$ .)

5B. The action of the modular group  $M$  is much more complicated than it was in the previous cases. We can no longer study  $M$  group theoretically but must work geometrically. Moreover, we cannot obtain as good a description of the space  $R(S)$  as we did before. We obtain a region  $R(S)$  which is a fundamental domain for  $T(S)$  in the following sense.

DEFINITION 5.1.  $R(S)$  is a rough fundamental domain for  $M(S)$  acting on  $T(S)$  if

(i)  $\bigcup_{\varphi \in M} \overline{\varphi(R(S))} = T(S)$ , and

(ii) the set  $\{\bigcup_{\varphi \in M} (\varphi(q) \cap R(S))\}$  is finite for each  $q \in T(S)$ .

Note that for a fundamental domain, the set of condition (ii) contains only one point for almost all  $q$ .

$M$  is generated by Dehn twists about the projections of the axes of  $A_1, B_1, A_2, B_2$  and  $B_2A_2^{-1}B_2^{-1}A_1$  ([5], [6]).

REMARK 5.1. A Dehn twist about a curve  $\gamma$  on the surface changes the free homotopy class of only those curves which intersect  $\gamma$ . Classes corresponding to curves disjoint from  $\gamma$  are left invariant. Consequently, twists about disjoint curves commute.

The elements of  $M$  are defined only up to free homotopy. We will assume, therefore, that the element  $\varphi \in M$  that we write down sends the geodesic of a free homotopy class into the geodesic of the image class. We denote a Dehn twist about the geodesic  $\gamma$  by  $\varphi_\gamma$ .

DEFINITION 5.2. A partition of a surface  $S$  of type  $(g; m)$  is a set of  $3g - 3 + m$  simple disjoint geodesics. Since there is a unique geodesic in each free homotopy class, this is the maximal number of such curves which a surface admits.

The partitions belonging to a surface of type  $(2; 0)$  contain 3 curves. In [15] we proved that at most one dividing geodesic can belong to a partition. We therefore define:

DEFINITION 5.3. A partition of type I on a surface of type  $(2; 0)$  contains a dividing geodesic. A partition of type II contains no dividing geodesic.

In [13] we proved

LEMMA 5.1. Let  $S$  be a surface of type  $(g; m)$  and let  $\alpha$  and  $\beta$  be simple geodesics on  $S$  which intersect. Then there is a number  $\rho > 0$ , which is independent of  $S$  and its type, such that  $\|\alpha\| \cdot \|\beta\| > \rho^2$ , where  $\|\alpha\|$  and  $\|\beta\|$  are the lengths of the geodesics.

Using this lemma, Bers proves the following theorem which is crucial to the arguments below.

THEOREM 5.2. Let  $S$  be a surface of type  $(g; m)$  and let  $l_1, \dots, l_m$  be the lengths of the geodesics corresponding to the holes. There exists a number  $L$  depending only on  $g$  and the numbers  $l_1, \dots, l_m$  such that  $S$  admits a partition in which each curve of the partition has length less than  $L$ .

We can assume without loss of generality that  $L \geq \rho$ .

**DEFINITION 5.4.** A partition in which each geodesic has length less than  $L$  is called a *B-partition*.

For surfaces  $S$  of type  $(2; 0)$  define

$$(5.5) \quad T^I(S) = \{S \in T(S) \mid S \text{ admits a } B\text{-partition of type I}\}$$

and

$$(5.6) \quad T^{II}(S) = \{S \in T(S) \mid S \text{ admits a } B\text{-partition of type II}\}.$$

We see that  $T(S)$  is the union of  $T^I(S)$  and  $T^{II}(S)$  and that these subspaces of  $T(S)$  have a nonempty intersection. We want to find rough fundamental domains for the action of  $M$  on each of these subspaces. Since each surface admits only a finite number of  $B$ -partitions, we look first at those elements of  $M$  which leave each curve of a given  $B$ -partition invariant.

All the closed curves we encounter below are really defined only up to free homotopy. Hence we will assume, unless specifically stated otherwise, that closed curves are geodesics.

If we consider a point in  $T(S)$  and look at those closed curves on  $S$  which are the projections of the axes of  $A_1, A_2$  and  $C$ , we obtain a partition of type I. If we consider the projections of the axes of  $A_1, A_2$  and  $A_1A_2$ , we obtain a partition of type II. If  $L$  is the bound in Bers' theorem 5.2, let  $\bar{L}$  be the corresponding bound on the traces of the conjugacy classes of elements of  $\Gamma$ .

Let  $R^I$  be the subset of  $T^I$  whose coordinates satisfy

$$\begin{aligned} 2 < x_1, x_2, \xi \leq \bar{L}, \quad x_1 \leq x_2, \quad x_i \leq y_i, \quad x_i \leq z_i, \\ x_i y_i - 2z_i \geq 0, \quad x_i z_i - 2y_i \geq 0, \quad i = 1, 2, \quad \xi \eta - 2\xi - J_3 \geq 0, \\ \xi \zeta - 2\eta - J_2 \geq 0, \quad \eta \zeta - 2\xi - J_1 \geq 0, \quad J_1 = x_1^2 + x_2^2, \\ J_2 = J_3 = 2x_1 x_2, \quad J_4 = 2x_1^2 + 2x_2^2 + x_1^2 x_2^2 - 4. \end{aligned}$$

**LEMMA 5.2.**  $\{\cup_{\varphi \in M} \varphi(R^I)\} \supset T^I$ .

**PROOF.** Let  $q$  be a point of  $T^I$ . By definition, the underlying marked surface  $S$  of  $q$  admits a  $B$ -partition of type I. Label the geodesics of the partition  $(\beta_1, \beta_2, \gamma)$  where  $\gamma$  is the dividing geodesic. Clearly,  $(\beta_1, \beta_2, \gamma)$  are *not* necessarily the geodesics arising from the marking. We want to use these closed curves to construct a new marking on  $S$  and, hence, an equivalent point  $\bar{q}$  to  $q$  such that  $\bar{q} \in R^I$ .  $\gamma$  divides  $S$  into two surfaces  $T_1$  and  $T_2$ , each of type  $(1; 1)$ . Each  $T_i$  can contain only one of the nondividing geodesics of the partition. Let  $T_1$  be the half containing  $\beta_1$  and  $T_2$  the half containing  $\beta_2$ .

Let  $k$  be the trace of the conjugacy class of elements in  $\Gamma$  determined by the geodesic  $\gamma$ . Let  $x_1$  and  $x_2$  be the corresponding traces for  $\beta_1$  and  $\beta_2$  and assume we have labelled so that  $x_1 \leq x_2$ . Using Theorem 3.2 we can find two unique points in the moduli space of surfaces of type  $(1; 1)$  which represent each  $T_i$  and whose coordinates  $x_i, y_i, z_i$  and  $k$  satisfy

$$x_i^2 + y_i^2 + z_i^2 - x_i y_i z_i - 2 = k, \quad x_i \leq y_i, z_i, \quad x_i y_i - 2z_i \geq 0, \quad x_i z_i - 2y_i \geq 0.$$

In this way we obtain curves  $\alpha_i$  on  $T_i$  so that the marking  $\{\alpha_i, \beta_i\}$  corresponds to the moduli  $x_i, y_i, z_i, i = 1, 2$ . We can obtain a marking for  $S$  by joining the intersection points of the geodesics  $\alpha_i, \beta_i$  by a curve (open



geodesic)  $\sigma$  and taking the intersection point of  $\alpha_1$  and  $\beta_1$  as base point. The marking is then  $\{\alpha_1, \beta_1, \sigma\alpha_2\sigma^{-1}, \sigma\beta_2\sigma^{-1}\}$ . We have much freedom in choosing  $\sigma$ .

However, if we consider the amalgamation process described in the statements before Theorem 5.2 we can apply Theorem 4.4 and choose  $\sigma$  so that the corresponding elements of the group  $\Gamma$  with this marking are  $A_1, B_1, A_2, B_2, C$  and if  $|\text{trace } C| = -k = \xi, |\text{trace } A_1B_2A_2B_2^{-1}| = \eta$  and  $|\text{trace } A_1A_2| = \zeta$ , then  $\xi, \eta$ , and  $\zeta$  satisfy  $\xi\eta - 2\zeta - J_3 \geq 0, \xi\zeta - 2\eta - J_2 \geq 0$  and  $\eta\zeta - 2\xi - J_1 \geq 0$ . Q.E.D.

LEMMA 5.3. *The set  $\{\cup_{\varphi \in M} \varphi(q) \cap R^I\}$  is finite for each  $q \in T^I$ .*

PROOF. For each point of  $R^I$ , the curves  $(\beta_1, \beta_2, \gamma)$  determined from a corresponding marking on the underlying surface form a  $B$ -partition of type I. Any surface admits only a finite number of  $B$ -partitions of type I without regard to marking. We therefore need to show only that for each unmarked surface  $S$ , with fixed  $B$ -partition of type I, there are only finitely many marked surfaces in  $R^I$ , with underlying surface  $S$ , such that the closed curves  $(\beta_1, \beta_2, \gamma)$  of the marking are the curves of the fixed partition. It is clear, however, from the construction of the point in  $R^I$  corresponding to a given point in  $T^I$ , that there are only finitely many such points. The construction is defined up to choice of orientation of curves and up to choice from among the points which lie on boundaries of the fundamental domains of Theorems 4.4 and 3.2. In any event there can be only finitely many points. Q.E.D.

Let  $R^{II}$  be the subset of  $T^{II}$  whose coordinates satisfy

$$2 \leq x_1 \leq x_2 \leq \xi \leq \bar{L}, \quad \xi\eta - 2\zeta - 2x_1x_2 \geq 0, \quad \xi\zeta - 2\eta - 2x_1x_2 \geq 0,$$

$$\eta\zeta - 2\xi - (x_1^2 + x_2^2) \geq 0 \quad \text{and} \quad x_i^2 + y_i^2 + z_i^2 - x_iy_iz_i + \eta - 2 = 0$$

with  $x_i \leq y_i, x_i \leq z_i$  and  $x_iy_i - 2z_i \geq 0, x_iz_i - 2y_i \geq 0, i = 1, 2$ .

LEMMA 5.4.  $\cup_{\varphi \in M} \overline{\varphi(R^{II})} \supset T^{II}$ .

PROOF. Let  $q$  be a point of  $T^{II}$ . By definition, the underlying surface  $S$  admits a partition of type II. Label the geodesics of such a partition  $(\beta_1, \beta_2, \beta_3)$  in order of increasing length. As in the proof of Lemma 5.2, we want to use these closed curves to construct a new marking on  $S$  and, hence, a point  $\bar{q}$  in  $R^{II}$  equivalent to  $q$ . In this case we first let  $S_0$  be the surface of type (0; 4) obtained from  $S$  by cutting along the geodesics  $\beta_1$  and  $\beta_2$ . We order the resulting holes so that the first and second correspond to the two sides of the  $\beta_1$  curve and the third and fourth to the two sides of the  $\beta_2$  curve. We let  $x_1$  and  $x_2$  be the corresponding traces. If  $\xi$  is the trace corresponding to the curve  $\beta_3$  which divides  $S_0$ , we can apply Theorem 4.4 to find  $\eta$  and  $\zeta$  satisfying

$$\begin{aligned} &\xi^2 + \eta^2 + \zeta^2 - \xi\eta\zeta + (x_1^2 + x_2^2)\xi \\ &\quad + 2x_1x_2(\eta + \zeta) + 2(x_1^2 + x_2^2) + x_1^2x_2^2 - 4 = 0 \end{aligned}$$

and

$$\xi\eta - 2\zeta - 2x_1x_2 \geq 0, \quad \xi\zeta - 2\eta - 2x_1x_2 \geq 0, \quad \eta\zeta - 2\xi - (x_1^2 + x_2^2) \geq 0.$$

Of the geodesics corresponding to  $\eta$  and  $\zeta$ , one of them must divide the original surface  $S$ . Since the pairs of holes of  $S_0$  have equal length, we can interchange  $\zeta$  and  $\eta$  and remain within the fundamental domain of Theorem 4.4. Therefore, we assume the geodesic corresponding to  $\eta$  is the one which divides on  $S$ ; call it  $\gamma$ .

We now divide  $S$  along  $\gamma$  as in the proof of Lemma 5.2 to obtain one holed tori,  $T_1$  and  $T_2$ . We use Theorem 3.2 to find geodesics  $\alpha_1$  and  $\alpha_2$  on  $T_1$  and  $T_2$  so that the corresponding traces  $y_i$  (and  $z_i$ ) satisfy

$$x_i^2 + y_i^2 + z_i^2 - x_i y_i z_i - \eta + 2 = 0, \quad i = 1, 2,$$

and

$$x_i < y_i, \quad x_i < z_i, \quad x_i y_i - 2z_i \geq 0, \quad x_i z_i - 2y_i \geq 0, \quad i = 1, 2.$$

We define the curve  $\sigma$  joining the intersection points of  $\alpha_i$  and  $\beta_i$  so that  $\xi$  is the trace corresponding to the curve  $\alpha_1 \sigma \alpha_2 \sigma^{-1}$  with base point the intersection of  $\alpha_1$  and  $\beta_1$ . This gives us the desired new marking on  $S$  and, hence, the point  $\bar{q} \in R^{\text{II}}$  which is equivalent to the original point  $q$ . Q.E.D.

LEMMA 5.5. *The set  $\{\cup_{\varphi \in M} [\varphi(q) \cap R^{\text{II}}]\}$  is finite for each  $q \in T^{\text{II}}$ .*

PROOF. We argue as in the proof of Lemma 5.3 and consider what choices we made in the construction of the proof of Lemma 5.4. Again the only choices are in orientation and from a finite set within or on the boundaries of the fundamental domains of Theorems 3.2 and 4.4. Q.E.D.

Combining these lemmas, we obtain

THEOREM 5.3. *A rough fundamental domain for  $M$  acting on the Teichmüller space  $T(S)$  of surfaces of type  $(2; 0)$  is the subspace  $R = R^{\text{I}} \cup R^{\text{II}}$  where  $R^{\text{I}}$  and  $R^{\text{II}}$  are defined above.*

**6. The Teichmüller space of surfaces of type  $(g; m)$ .** The construction of Teichmüller space for surfaces of type  $(g; m)$  is analogous to that for surfaces of type  $(0; 4)$  and that for surfaces of type  $(2; 0)$ . We break up a surface of type  $(g; m)$  into simple subsurfaces of types  $(1; 1)$  and  $(0; 3)$ , we construct spaces for each of these simple surfaces and then combine them as we did in §§4A and 5A. The construction proceeds as follows. We consider the marked surface and determine a set of geodesics on the surface from the marking which we call *moduli curves*. There are three types of moduli geodesics: *dividing curves*, *handle curves* and *twist curves*. The dividing curves break up the surface into the subsurfaces; the handle curves are on the tori; and the twist curves are those which occur in the recombination process.

As in §4A, it is easier to work with marked Fuchsian groups and the traces of their elements than to work directly with the surface. The axes of the elements we look at project onto the moduli curves on the surface. Those elements whose axes project onto handle curves are the *handle elements*, those whose axes project onto dividing curves are the *dividing elements*, and those whose axes project onto twist curves are the *twist elements*.

Let  $\Gamma$  be the marked Fuchsian group and let  $\mathfrak{S} = \{A_1 B_1, \dots, A_g, B_g, D_1, \dots, D_m\}$  be the canonical presentation. The elements  $A_i, B_i$  and  $A_i B_i$ ,  $i = 1, \dots, g$ , are the handle elements; let  $x_i = |\text{trace } A_i|$ ,  $y_i = |\text{trace } B_i|$ ,  $z_i = |\text{trace } A_i B_i|$ . Let  $C_i = B_i^{-1} A_i^{-1} B_i A_i$ ,  $i = 1, \dots, g$ . These are dividing

elements; let  $k_i = |\text{trace } C_i|$ ,  $i = 1, \dots, g$ . The elements  $D_j$ ,  $j = 1, \dots, m$ , are also dividing; let  $k_{g+j} = |\text{trace } D_j|$ ,  $j = 1, \dots, m$ . Consider further the dividing elements  $C_2C_1 = E_1$ ,  $C_3C_2C_1 = E_2, \dots, C_g \cdots C_1 = E_{g-1}$ ,  $D_1C_g \cdots C_1 = E_g, \dots, D_{m-2}D_{m-1} \cdots D_1C_g \cdots C_1 = E_{g+m-3}$ ; let  $\eta_j = |\text{trace } E_j|$ ,  $j = 1, \dots, g + m - 3$ .

DEFINITION 6.1. The projections of the axes of  $A_1, \dots, A_g, C_1, \dots, C_g$  and  $E_1, \dots, E_{g+m-3}$  form a partition on the underlying surface  $S$ ; we call this partition a *canonical partition* for the marked surface  $S$  or for the marked group  $\Gamma$ .

Cutting  $S$  along the curves corresponding to  $C_1, \dots, C_g$  and  $E_1, \dots, E_{g+m-3}$  renders it into  $g$  surfaces of type (1; 1) and  $g + m - 2$  surfaces of type (0; 3). Label as  $T_i$  the (1; 1) surface bounded by the dividing curves corresponding to  $C_i$ ,  $i = 1, \dots, g$ . Set  $E_0 = C_1$ ,  $C_{g+j} = D_j$ ,  $j = 1, \dots, m - 1$ , and  $E_{g+m-2} = D_m$ . Then label as  $S_j$  the (0; 3) surface bounded by the dividing curves corresponding to  $E_{j-1}$ ,  $E_j$ , and  $C_{j+1}$ ,  $j = 1, \dots, g + m - 2$ .  $T_1$  is attached to  $S_1$ ,  $T_{i+1}$  is attached to  $S_i$ ,  $i = 2, \dots, g - 1$ . (If  $m = 0$  both  $T_{g-1}$  and  $T_g$  are attached to  $S_{g-2}$ .)

Using the constructions in §§4 and 5 as models, we consider pairs of twist curves which intersect the boundary curves of the subsurfaces. The traces of the corresponding twist elements are the parameters determining the twists. For convenience below we label the geodesics with the names of the corresponding group elements.

Across  $C_1$ :  $A_1C_2$  and  $A_2E_1$ ; set  $|\text{trace } A_1C_2| = l_1$ ,  $|\text{trace } A_2E_1| = m_1$ ,

Across  $C_i$ :  $A_iE_{i-2}$  and  $A_iE_{i-1}$ ; set  $|\text{trace } A_iE_{i-2}| = l_i$ ,  $|\text{trace } A_iE_{i-1}| = m_i$ ,  $i = 2, \dots, g$ .

The surface  $S_j$  is attached to the surface  $S_{j+1}$ . The twists in this case are:

Across  $E_j$ :  $E_{j-1}E_{j+1}$  and  $C_{j+1}E_{j+1}$ , set

$$|\text{trace } E_{j-1}E_{j+1}| = \xi_j, |\text{trace } C_{j+1}E_{j+1}| = \zeta_j, \quad j = 1, \dots, g + m - 3.$$

THEOREM 6.1. The Teichmüller space of surfaces of type  $(g; m)$  is the  $6g + 3m - 6$  dimensional subspace of  $\mathbf{R}^{9g+4m-9}$  spanned by the parameters  $x_i, y_i, z_i, k_i, l_i, m_i, i = 1, \dots, g, k_{g+j}, j = 1, \dots, m, \xi_j, \eta_j, \zeta_j, j = 1, \dots, g + m - 3$ , each varying in the interval  $(2, \infty)$  and subject to the  $3g + m - 3$  constraints

$$(6.2.1) \quad x_i^2 + y_i^2 + z_i^2 - x_i y_i z_i - 2 + k_i = 0, \quad i = 1, \dots, g.$$

$$(6.2.2) \quad k_i^2 + l_i^2 + m_i^2 - k_i l_i m_i + J_1^i k_i + J_2^i l_i + J_3^i m_i + J_4^i = 0$$

where

$$J_1^i = x_i^2 + \eta_{i-1} \eta_{i-2}, \quad J_2^i = x_i (\eta_{i-1} + \eta_{i-2}) = J_3^i, \\ J_4^i = 2x_i^2 + \eta_{i-1}^2 + \eta_{i-2}^2 + x_i^2 \eta_{i-1} \eta_{i-2} - 4, \quad i = 1, \dots, g,$$

and

$$(6.2.3) \quad \xi_j^2 + \eta_j^2 + \zeta_j^2 - \xi_j \eta_j \zeta_j + K_1^j \xi_j + K_2^j \eta_j + K_3^j \zeta_j + K_4^j = 0$$

where

$$K_1^j = \eta_{j-1} \eta_{j+1} + k_{j+1} k_{j+2},$$

$$K_2^j = \eta_{j+1} k_{j+2} + \eta_{j-1} k_{j+1},$$

$$\begin{aligned}
 K_3^j &= \eta_{j-1}k_{j+1} + \eta_{j+1}k_{j+2} \quad \text{and} \\
 K_4^j &= \eta_{j-1}^2 + \eta_{j+1}^2 + k_{j+1}^2 + k_{j+2}^2 + \eta_{j-1}\eta_{j+1}k_{j+1}k_{j+2} - 4, \\
 & \qquad \qquad \qquad j = 1, \dots, g + m - 3.
 \end{aligned}$$

PROOF. The proof is given in [11], [12].

**7. Partitions.** If  $S$  is a surface of type  $(g; m)$  the action of the modular group  $M$  on the space  $T(S)$  is quite complicated. Therefore, as in §5B, we make critical use of Bers' Theorem 5.2. Partitions play a crucial role in this approach and we turn our attention now to a classification of them.

Recall that a partition on a surface of type  $(g; m)$  consists of  $3g - 3 + 2m$  simple closed mutually disjoint geodesics.  $m$  of these are the dividing geodesics of the free homotopy classes of the boundary curves. Cutting the surface along all the curves of a partition yields  $m$  infinite funnels and  $2g + m - 2$  surfaces of type  $(0; 3)$  truncated along the boundary geodesics. Each such sphere with three holes is attached to one, two or three other such spheres across its boundary curves. It may or may not be attached to itself. The ways in which these spheres are attached are invariant under topological mappings.

In our construction in §5B, we were able to use  $B$ -partition geodesics as moduli curves. For the cases of higher genus, many types of partitions are such that not all of the partition geodesics can be used as moduli curves. As we shall see, the dividing curves of the partition may always be used as moduli curves, hence the more dividing curves a partition has, the easier it is to handle with our methods.

LEMMA 7.1. *The maximum number of dividing curves in a partition on a surface of type  $(g; m)$  is  $2g + 2m - 3$ .*

PROOF. Since the boundary geodesics are dividing by definition, there are always at least  $m$  dividing curves.

First we consider the special case  $g = 0$  and prove the theorem by induction on  $m$ . On a surface of genus zero any simple closed curve is dividing. Therefore, we need to count how many disjoint homotopically nontrivial curves we can have on such a surface. If  $m = 3$ , any simple closed curve is homotopic to one of the boundary curves so the theorem is true. Assume it is true for surfaces of type  $(0; k)$ ,  $k < m$ . Now let  $S$  be a surface of type  $(0; m)$ ,  $m > 3$ , and let  $\gamma$  be any simple closed geodesic on  $S$  which is not homotopic to a boundary curve.  $\gamma$  divides  $S$  into two surfaces,  $S_1$  of type  $(0; k)$  and  $S_2$  of type  $(0; l)$ , such that  $k + l = m + 2$  and  $k, l \geq 3$ . Hence,  $k, l < m$  and by the induction hypothesis we can find a maximal set of  $2k - 3$  disjoint simple closed dividing curves on  $S_1$  and a maximal set of  $2l - 3$  disjoint simple closed dividing curves on  $S_2$ . Since  $\gamma$  is counted on both  $S_1$  and  $S_2$  we have  $2k - 3 + 2l - 3 - 1 = 2m - 3$  disjoint simple closed dividing curves on  $S$ . This set is maximal since any simple closed geodesic not intersecting  $\gamma$  lies either wholly on  $S_1$  or wholly on  $S_2$ .

We turn now to the general case of a surface of type  $(g; m)$  and prove the theorem by induction on  $g$ . We assume it is true for all surfaces of type  $(k; m)$ ,  $k < g$ , and let  $S$  be the given surface of type  $(g; m)$ . Let  $\gamma_1$  be any simple closed dividing geodesic on  $S$  and let  $S_1$  and  $S'_1$  be the two surfaces into which  $\gamma_1$  renders  $S$ . If their types are, respectively,  $(g_1; m_1)$  and  $(g'_1; m'_1)$ , then

$g_1 + g'_1 = g$  and  $m_1 + m'_1 = m + 2$ . If  $g_1$  and  $g'_1$  are both nonzero we apply the induction hypothesis to  $S_1$  to obtain a maximal set of  $2g_1 + 2m_1 - 3$  disjoint simple closed dividing curves on  $S_1$ , and to  $S'_1$  to obtain a maximal set of  $2g'_1 + 2m'_1 - 3$  simple closed dividing curves on  $S'_1$ . Then since  $S = S_1 \cup S'_1$  and  $\gamma_1$  is counted on both  $S_1$  and  $S'_1$  we have  $2g_1 + 2m_1 - 3 + 2g'_1 + 2m'_1 - 3 - 1 = 2g + 2m - 3$  disjoint simple dividing curves on  $S$ . Any other simple dividing geodesic disjoint from  $\gamma_1$  lies wholly either on  $S_1$  or  $S'_1$  and by the maximality condition of the induction hypothesis must intersect some curve of the set on  $S_1$  or  $S'_1$ .

Suppose that  $g'_1 = 0$ ; then there is a maximal set of  $2m'_1 - 3$  disjoint simple dividing curves on  $S'_1$ . Let  $\gamma_2$  be a simple dividing geodesic on  $S_1$ . Let  $S_2$  and  $S'_2$  be the resulting surfaces of respective types  $(g_2; m_2)$  and  $(g'_2; m'_2)$ ;  $g_2 + g'_2 = g_1 = g$ ,  $m_2 + m'_2 = m_1 + 2$ . As above if neither  $g_2$  nor  $g'_2$  is zero the induction hypothesis implies the desired conclusions. If  $g'_2 = 0$  we continue recursively; at the  $i$ th step we obtain a surface of type  $(g; m_i)$  with  $m_i \leq m_{i-1} - 1$ . After  $n$  steps the geodesic  $\gamma_n$  renders  $S_{n-1}$  into  $S_n$  and  $S'_n$  such that  $S_n$  has type  $(g; 1)$  and  $S'_n$  has type  $(0; m'_n)$ . If  $g = 1$  there is only one simple dividing curve on  $S_n$ , the boundary curve. If  $g > 1$ , any simple closed dividing geodesic  $\gamma_{n+1}$  on  $S_n$  not homotopic to the boundary curve divides  $S_n$  into two surfaces  $S_{n+1}$  and  $S'_{n+1}$  of respective types  $(g_{n+1}; m_{n+1})$  and  $(g'_{n+1}; m'_{n+1})$  where  $g_{n+1}, g'_{n+1} > 0$ ,  $g_{n+1} + g'_{n+1} = g$ ,  $m_{n+1} + m'_{n+1} = m_n + 2 = 3$ . Let  $S' = \cup_{i=1}^{n+1} S'_i$ .  $S'$  has type  $(g'_{n+1}; m - m_{n+1} + 2)$ ; applying the induction hypothesis to  $S'$  we find a maximal set of  $2g'_{n+1} + 2(m - m_{n+1}) + 1$  disjoint simple closed dividing curves on  $S'$ . Similarly we find a maximal set of  $2g_{n+1} + 2m_{n+1} - 3$  disjoint simple closed dividing curves on  $S_{n+1}$ .  $S = S' \cup S_{n+1}$  and  $\gamma_{n+1}$  is counted on both  $S'$  and  $S_{n+1}$  so that we have  $2g + 2m - 3$  disjoint simple closed curves on  $S$ . Again the maximality of the sets of geodesics on the subsurfaces implies we have a maximal set for  $S$ . Q.E.D.

The next lemma is a generalization of Lemma 5.2.

**LEMMA 7.2.** *Let  $S$  of type  $(g; m)$  be given with a partition  $P$  which has  $2g + 2m - 3$  dividing curves. There is a marking for  $S$ , and hence for the Fuchsian group  $\Gamma$  representing  $S$ , such that the canonical partition for the marked group  $\Gamma$  is precisely  $P$ .*

**PROOF.** Let  $S$  be the given surface of type  $(g; m)$  and let  $P$  be a partition on  $S$ ,  $2g + 2m - 3$  of whose curves are dividing; the remaining  $g$  curves are nondividing. The dividing curves render  $S$  into  $g$  surfaces of type  $(1; 1)$  and  $g + m - 2$  surfaces of type  $(0; 3)$ . On each surface  $T_i$ , of type  $(1; 1)$ , label the nondividing geodesic  $\alpha_i$  and the boundary geodesic  $\gamma_i$ . Then, according to Theorem 3.2 we can find a nondividing geodesic  $\beta_i$  on  $T_i$  such that the traces of the group elements corresponding to  $\alpha_i, \beta_i, \alpha_i\beta_i$  and  $\gamma_i$  satisfy the inequalities stated therein. These inequalities yield bounds for the lengths of  $\beta_i$  and  $\alpha_i\beta_i$  in terms of the lengths of the partition curves  $\alpha_i$  and  $\beta_i$ .  $\alpha_i$  and  $\beta_i$  generate the fundamental group of  $T_i$  and the base point  $p_i$  can be taken as their intersection point.

According to the proof of Theorem 2.1 we can find a point  $q_j$  on each surface  $S_j$  of type  $(0; 3)$  such that if  $\gamma_j^1, \gamma_j^2$  and  $\gamma_j^3$  are the three boundary curves of  $S_j$  and  $\sigma_j^1, \sigma_j^2, \sigma_j^3$  are open geodesics joining  $q_j$  to each of the three curves  $\gamma_j^1, \gamma_j^2$  and  $\gamma_j^3$ , respectively, then the curves  $\sigma_j^1\gamma_j^1(\sigma_j^1)^{-1}, \sigma_j^2\gamma_j^2(\sigma_j^2)^{-1}$  and

$\sigma_j^3 \gamma_j^3 (\sigma_j^3)^{-1}$  generate the fundamental group for  $S_j$  with base point  $q_j$ .

According to the proof of Theorem 4.4, for each pair of adjacent sub-surfaces  $S_j$  and  $S_k$  (or  $T_k$ ), there exists a geodesic joining  $q_j$  to  $q_k$  (or  $p_k$ ), such that if  $\gamma_j^1, \gamma_j^2$  and  $\gamma_k^1, \gamma_k^2$  (or  $\alpha_k, (\alpha_k)^{-1}$ ) are the boundary curves of the union, then the traces of the group elements corresponding to  $\gamma_j^1, \gamma_j^2, \gamma_k^1, \gamma_k^2, \gamma_j^3 = \gamma_k^3, \gamma_j^1 \gamma_k^2, \gamma_j^1 \gamma_k^1$  satisfy the inequalities stated therein. These inequalities yield bounds for the lengths of the moduli curves  $\gamma_j^1 \gamma_k^2$  and  $\gamma_j^1 \gamma_k^1$  in terms of the lengths of the partition curves  $\gamma_j^1, \gamma_j^2, \gamma_j^3, \gamma_k^1$  and  $\gamma_k^2$ .

If we now choose  $p_1$  as base point, and consider all the curves we have on the surface as joined by the open geodesics to  $p_1$ , they constitute a canonical basis for the fundamental group of  $S$ . The canonical partition for the correspondingly marked group  $\Gamma$  is precisely the partition with which we began. Q.E.D.

In view of this lemma, we can refer below to partitions with a maximal number of dividing curves as canonical partitions. Since from our point of view canonical partitions are most desirable, we want to classify topologically different types of partitions in terms of their deviation from canonical partitions.

Given a partition  $P$  on a surface  $S$ , we first determine the number  $d_0 = d_0(P)$  of dividing curves in the partition. Since any simple closed geodesic on  $S$  which doesn't belong to the partition intersects at least one partition curve, we ask the following question. Consider all possible simple dividing geodesics which we can draw on the surface which are disjoint from the  $d_0$  dividing curves of  $P$ ; then what is the least number  $n_1 = n_1(P)$  of partition curves which are intersected by such a dividing curve? If  $S$  has type  $(2; 0)$ , either  $d_0 = 1$  or  $d_0 = 0$  and  $n_1 = 1$ . We now draw as many as possible mutually disjoint simple dividing curves which are disjoint from the  $d_0$  dividing partition curves and which intersect  $n_1$  partition curves. Call this number  $d_{n_1} = d_{n_1}(P)$ . Clearly  $d_{n_1} \leq 2g + 2m - 3$ .

We continue in a recursive fashion. We look at all simple dividing curves which we may now draw on  $S$  which are disjoint from the original  $d_0$  partition dividing curves and also from the  $d_1$  new dividing curves we have added. What is the least number  $n_2 = n_2(P)$  of nondividing partition curves that one of these geodesics must intersect? Let  $d_{n_2}$  be the maximum number of mutually disjoint such curves. If  $d_0 + d_{n_1} + d_{n_2} = 2g + 2m - 3$  we are done;

Figure 5 illustrates the various possible types of partitions when  $S$  has type  $(3; 0)$ .

Before looking at the general picture we consider the following special case.

**LEMMA 7.3.** *Let  $T$  be a surface of type  $(1; 2)$  and suppose  $P$  is a partition on  $T$  without a dividing curve. We can find a dividing curve on  $T$  whose length is bounded in terms of the lengths of the partition curves, in the sense described in the proof of Lemma 7.2.*

**PROOF.** Label the boundary curves of  $T$ ,  $\delta_1$  and  $\delta_2$ . Label the other two nondividing partition curves  $\gamma_1$  and  $\gamma_2$ . We can consider  $T$  as a sphere with four holes, two of which are identified. Let the four holed sphere have curves  $\delta_1, \delta_2, \gamma_1, \gamma_1^{-1}$  as boundary curves. We can find a geodesic  $\sigma$  in the class

determined by  $\delta_1, \delta_2$  whose length is bounded in terms of the lengths of  $\gamma_1, \delta_1, \delta_2$  and  $\gamma_2$  by using Theorem 4.4 as we did in the proof of Lemma 7.2.  $\sigma$  is dividing; it divides  $T$  into a torus with one hole (bounded by  $\sigma$ ) and a sphere with three holes (bounded by  $\sigma, \delta,$  and  $\delta_2$ ). (See Figure 6.)

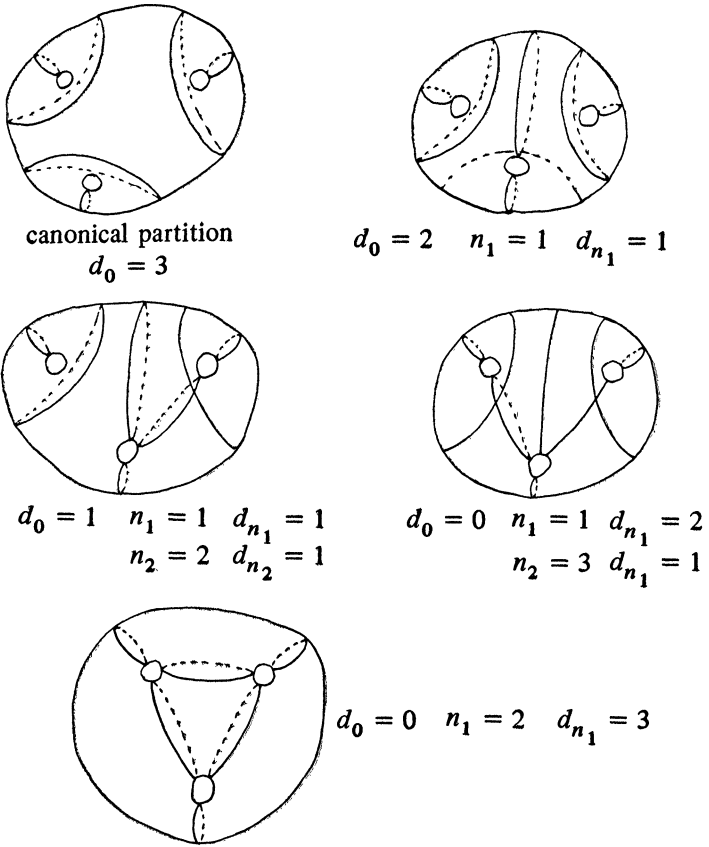

FIGURE 5

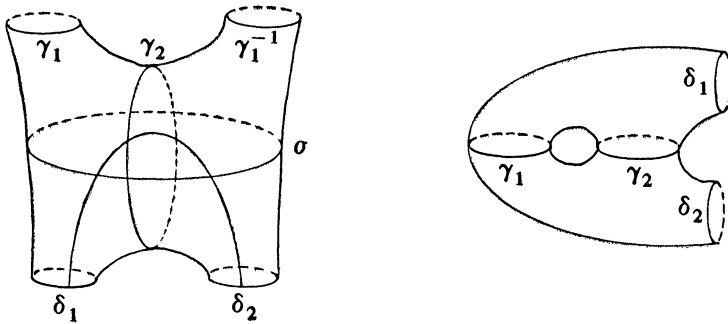

FIGURE 6

LEMMA 7.4. *Let  $S$  be a surface of type  $(g; m)$  and let  $P$  be any partition on  $P$ . We can find a new partition  $\tilde{P}$  on  $S$  which is canonical and such that the lengths of the curves of the new partition are bounded in terms of a set of inequalities involving the lengths of the curves of the original partition.*

PROOF. We may assume  $6g - 6 + 3m > 6$  since we have treated all the other possibilities above. Moreover, let us assume that the given partition is not canonical because in that case the theorem holds trivially.

Let  $\sigma$  be a simple closed dividing curve on  $S$  which intersects exactly  $n_1(P)$  nondividing partition curves. First, suppose  $n_1 = 1$ , and let  $\gamma$  be the partition curve which  $\sigma$  intersects.  $\gamma$  is the boundary curve of two distinct  $(0; 3)$  surfaces,  $S_1$  and  $S_2$  determined by the partition. Were  $S_1 = S_2$ ,  $S_1 \cup S_2$  identified across  $\gamma$ , would be a surface of type  $(1; 1)$  and there is a unique dividing geodesic on such a surface which doesn't intersect any simple nondividing geodesic on it; hence  $S_1$  and  $S_2$  are distinct.  $S_1 \cup S_2$  is, therefore, either a surface of type  $(0; 4)$ , if the remaining boundary curves are all distinct, or a surface of type  $(1; 2)$  otherwise. Since we are assuming  $6g - 6 + 3m > 6$ , these are the only possibilities. In either of these cases,  $\sigma$  can be chosen so that its length is bounded in terms of the lengths of the partition curves using the method of Lemma 7.3 or Theorem 4.4.

Suppose now  $n_1(P) > 1$ . Travelling in a given direction along  $\sigma$ , let  $\gamma_1, \gamma_2$  and  $\gamma_3$  be three consecutive partition curves which  $\sigma$  intersects. Although  $\sigma$  intersects each partition curve twice, we may, since  $n_1 > 1$ , choose  $\gamma_1, \gamma_2$  and  $\gamma_3$  so that  $\gamma_1$  and  $\gamma_2$  are distinct. Let  $S_1$  be the  $(0; 3)$  surface two of whose boundary curves are  $\gamma_1$  and  $\gamma_2$ . Let  $S_2$  be the  $(0; 3)$  surface two of whose boundary curves are  $\gamma_2$  and  $\gamma_3$ . Unless  $\gamma_3 = \gamma_2$  or  $\gamma_3 = \gamma_1$ ,  $S_1$  and  $S_2$  are uniquely determined. If  $\gamma_3 = \gamma_2$ ,  $S_1$  is uniquely determined and either  $S_2 = S_1$  or  $S_2$  is an adjacent three-holed sphere; we choose  $S_2 \neq S_1$ . If  $\gamma_3 = \gamma_1$  the union of  $S_1$  and  $S_2$  across  $\gamma_1$  is uniquely determined although which three-holed surface should be called  $S_1$  and which  $S_2$  is not determined. The union in this case is a surface of type  $(1; 2)$  and the length of  $\sigma$  can be bounded in terms of the lengths of the partition curves by Lemma 7.3. (See Figure 7.)

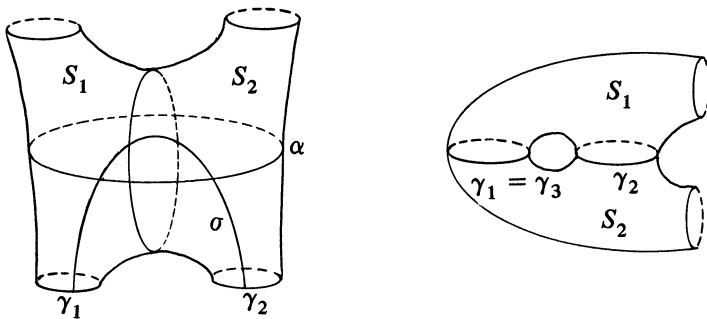

FIGURE 7



In the nonexceptional case  $\gamma_1 \neq \gamma_2 \neq \gamma_3$ ; on the four-holed sphere which is the union of  $S_1$  and  $S_2$  across  $\gamma_2$ , we can find a curve  $\alpha_1$  in the class determined by  $\gamma_1\gamma_3$  whose length is bounded by the lengths of the partition curves as in §4B. Since  $\alpha_1$  and  $\sigma$  are geodesics they don't intersect. Moreover, since  $\alpha_1$  is on the four-holed sphere  $S_1 \cup S_2$ , the only partition curve it intersects is  $\gamma_2$ . Now consider the revised partition  $P^1$  on the whole surface whose curves are  $\alpha_1$  and all those of  $P$  except  $\gamma_2$ . For this partition the number  $n_1(P^1)$  is  $n_1(P) - 1$ . We can repeat this process to find  $\alpha_2$  whose length is bounded in terms of the lengths of the original curves and  $\alpha_1$ . We revise the partition  $P^1$  to obtain  $P^2$  where  $\alpha_2$  replaces another partition curve and such that  $n_1(P^2)$  is  $n_1(P) - 2$ . After  $n_1 - 1$  such steps,  $n_1(P^{n_1-1}) = 1$  and we can obtain  $\alpha_{n_1}$ , which is dividing as in the first part of the proof. The length of  $\alpha_{n_1}$  is bounded in terms of a series of inequalities involving the original partition curves and  $\alpha_1, \dots, \alpha_{n_1-1}$ . Moreover,  $\alpha_{n_1}$  intersects  $n_1$  of the original partition curves. The revised partition  $P^{n_1}$  has one more dividing curve than  $P$  does:  $d_0(P^{n_1}) = d_0(P) + 1$ .

We repeat the above procedure for the partition  $P^{n_1} = \bar{P}$  starting with a dividing geodesic  $\sigma$  which is disjoint from all of the original dividing curves, and also from  $\alpha_{n_1}$ , and such that  $\sigma$  intersects a minimal number,  $n_1(\bar{P})$ , of nondividing curves of the partition  $\bar{P}$ . We obtain a revision  $\bar{P}$  of  $\bar{P}$  which has  $d_0(P) + 2$  dividing curves. Repeating this procedure a finite number of times we obtain a revised partition with a maximal number of dividing curves and such that the lengths of the curves of the revised partition are bounded in terms of a sequence of inequalities involving the lengths of the original partition curves and the lengths of the curves of the intermediary revised partitions. Q.E.D.

**8. The rough fundamental domain.** Let  $T(S)$  be the Teichmüller space of surfaces of type  $(g; m)$ . Let the numbers  $\lambda_1, \lambda_2, \dots, \lambda_m$  be given. Let  $\mathring{T}(S)$  be the subset of  $T(S)$  such that the moduli  $(k_{g+1}, k_{g+2}, \dots, k_{g+m})$ , corresponding to the boundary curves are some permutation of the  $m$ -tuple  $(\lambda_1, \dots, \lambda_m)$ . Let  $M$  be the Teichmüller modular group. It clearly acts on  $\mathring{T}(S)$ . Let  $r$  be the number of topologically distinct types of partitions that a surface of type  $(g; m)$  admits. Recalling definition 5.5 we define  $\mathring{T}^\nu(S) = \{S \in \mathring{T}(S) | S \text{ admits a } B\text{-partition of type } \nu\}$ ,  $\nu = 1, \dots, r$ . As in §5B we see that  $\mathring{T}(S)$  is the union of these subspaces and that they have a nonempty intersection. Let  $T^\nu(S)$  be the union of  $\mathring{T}^\nu(S)$  as the numbers  $\lambda_1, \dots, \lambda_m$  vary from 2 to  $\infty$ . Then

$$T(S) = \bigcup_{\nu=1}^r T^\nu(S).$$

Let  $q$  be a point in  $\mathring{T}^\nu(S)$  and let  $S$  be the underlying surface. For any  $B$ -partition of type  $\nu$  on  $S$ , we can, by Lemma 7.4, find a canonical partition such that the lengths of the dividing curves of the canonical partition satisfy a set of inequalities involving the bound  $L$  on the lengths of the  $B$ -partition curves. By Lemma 7.2 we can find a marking from the canonical partition such that the twist curves have lengths which satisfy inequalities involving the bound  $L$  also.

Let  $\mathring{R}^\nu$  be the subset of  $\mathring{T}^\nu(S)$  such that if  $\bar{L} = 2 \cosh(L/2)$ , the handle

moduli  $x_i$  satisfy  $x_i \leq \bar{L}$ ,  $i = 1, \dots, g$ , and such that the dividing and twist moduli satisfy the inequalities of Lemmas 7.2 and 7.4. (Recall Lemmas 5.2 and 5.4.)

LEMMA 8.1.  $\mathring{T}^\nu(S) = \bigcup_{\varphi \in M} \overline{\varphi(\mathring{R}^\nu)}$ .

PROOF. Every point in  $\mathring{T}^\nu(S)$  admits a  $B$ -partition of type  $\nu$  and Lemmas 7.2 and 7.4 describe an algorithm to construct a point in  $\mathring{R}^\nu$  congruent to the point. Q.E.D.

LEMMA 8.2. *The set  $\{\bigcup_{\varphi \in M} \varphi(q) \cap \mathring{R}^\nu\}$  is finite for each  $q \in \mathring{T}^\nu(S)$ .*

PROOF. For each point of  $\mathring{R}^\nu$ , we can read off, in terms of the moduli curves, a set of curves on the underlying surface  $S$  which form a  $B$ -partition of type  $\nu$ . The surface  $S$  admits only finitely many different  $B$ -partitions of type  $\nu$ . Looking at the proofs of lemmas 7.2 and 7.4 we see that corresponding to each possible  $B$ -partition of type  $\nu$  there are only finitely many points in  $\mathring{T}^\nu$  satisfying the inequalities which define  $\mathring{R}^\nu$ . Q.E.D.

Let  $R^\nu$  be the subset of  $T^\nu(S)$  formed by taking the union of the sets  $\mathring{R}^\nu$  as the parameters  $\lambda_i$ ,  $i = 1, \dots, m$ , vary from 2 to  $\infty$ . We have finally

THEOREM 8.1. *A rough fundamental domain for  $M$  acting on  $T(S)$  is the subspace  $R = \bigcup_{\nu=1}^r R^\nu$ .*

PROOF. Every point in  $T(S)$  lies in some  $\mathring{T}^\nu(S)$  and, hence, by Lemma 8.1, is congruent to some point in  $\mathring{R}^\nu$  which in turn belongs to  $\mathring{R}^\nu$ . Moreover, every point  $q \in T(S)$  belongs to only finitely many of the subspaces  $T^\nu(S)$  and, hence, to only finitely many of the subspaces  $\mathring{T}^\nu(S)$ . Consequently, by Lemma 8.2, the set  $\{\bigcup_{\varphi \in M} \varphi(q) \cap T(S)\}$  is finite. Q.E.D.

**9. Cusps.** We now consider the boundary of  $T(S)$ ,  $\partial T(S)$ . A point on the boundary corresponds again to a marked Fuchsian group such that if  $\Gamma$  is a normalized marked group in the interior of  $T(S)$  and  $\Gamma_0$  is a normalized marked group on the boundary, there is a natural homomorphism  $f: \Gamma \rightarrow \Gamma_0$ . There is no longer a quasi-conformal homeomorphism of the underlying surfaces though.

DEFINITION 9.1. A marked group  $\Gamma_0$  on the boundary of  $T(S)$  is called a *cusps* if for some hyperbolic element  $A \in \Gamma$ ,  $f(A)$  is parabolic, that is,  $|\text{tr } f(A)| = 2$ . See [3], [19].

Geometrically, in a neighborhood of a cusp  $\Gamma_0$ , there is a sequence of marked groups  $\Gamma_n$  in  $T(S)$ ,  $\Gamma_n \rightarrow \Gamma_0$ , such that on  $q_n$ , the underlying marked surface, there is a distinguished geodesic  $\gamma_n$  and the length of  $\gamma_n$  tends to 0 as  $n$  tends to  $\infty$ .

LEMMA 9.1. *Let  $T(S)$  be either the Teichmüller space of surfaces of type (1; 1) or (0; 4). Let  $k$  be the boundary modulus in the (1; 1) case; let  $(k_1, k_2, k_3, k_4)$  be the boundary moduli in the (0; 4) case. Let  $R(S)$  be the fundamental domain for  $M(S)$  acting on  $T(S)$  constructed in §§3B or 4B, respectively, such that each of the boundary moduli is bounded by an arbitrary constant  $M$ . Then  $\mathring{R}(S) \cap \partial T(S)$  is a set of cusps.*

PROOF. We carry out the proof for the case where  $S$  has type (1; 1). The

computation when  $S$  has type  $(0; 4)$  is analogous.

The domain  $R(S)$  is described by the relation  $x^2 + y^2 + z^2 - xyz - 2 + k = 0$ , and the inequalities  $xy - 2z > 0$ ,  $xz - 2y > 0$ ,  $x \leq y$ ,  $x \leq z$ ,  $x, y, z \geq 2$ ,  $2 < k < M$ . We want to show that if any of the parameters tend to  $\infty$  within  $R(S)$  some other parameter tends to 2. Our restriction on  $k$  says it cannot tend to  $\infty$ . Recall that for a fixed  $k$  and  $x = \lambda$ ,  $y$  and  $z$  lie on the minimal segment of the hyperbola  $y^2 + z^2 - 2\lambda yz + \lambda^2 - 2 + k = 0$ . Let the coordinates of the endpoint of the minimal segment such that  $\lambda y = 2z$  be  $(\lambda, y_0, \lambda_0/2)$ . The inequalities defining the minimal segment are then  $y_0 \leq y \leq \lambda y_0/2$ ,  $y_0 \leq z \leq \lambda y_0/2$ . As  $y$  and  $z$  tend to  $\infty$ ,  $y_0$  tends to  $\infty$ . Since

$$\lambda^2 + y_0^2 - \frac{\lambda^2 y_0^2}{4} - 2 + k = 0, \quad \lambda^2 = 4 \left[ \frac{y_0^2 - 2 - k}{y_0 - 4} \right]$$

as  $y_0$  tends to  $\infty$ ,  $\lambda$  tends to 2. Q.E.D.

The following theorem was conjectured by Bers [3].

**THEOREM.** *Let  $T(S)$  be the Teichmüller space of surfaces of type  $(g; m)$ . Let  $R(S)$  be the rough fundamental domain constructed in §8 such that the boundary moduli are all less than some arbitrary constant  $M$ . Then  $R(S) \cap \partial T(S)$  is a set of cusps.*

**PROOF.** We want to show that whenever one of the moduli tends to  $\infty$  within the region  $R(S)$ , there is some curve on the underlying surface such that the trace of the corresponding group element tends to 2. We need only consider those moduli curves which are not elements of a  $B$ -partition on the surface since the latter remain bounded by definition.

Let  $\sigma$  be a moduli curve whose length tends to  $\infty$  as we travel along a path in  $R(S)$ . Suppose  $\alpha$  is a  $B$ -partition curve which  $\sigma$  intersects and which is also a moduli curve. There are various possibilities. Either  $\alpha$  is a handle curve and  $\sigma$  lies on the handle determined by  $\alpha$  in the algorithm for constructing  $R(S)$ , in which case, via Lemma 9.1 it follows that the modulus corresponding to  $\alpha$  tends to 2; or  $\alpha$  is a twist curve and  $\sigma$  lies on a subsurface of type  $(0; 4)$  determined by the twist  $\alpha$ , in which case, again by Lemma 9.1, the modulus corresponding to  $\alpha$  tends to 2.

If  $\sigma$  intersects no  $B$ -partition curve which is also a moduli curve, we must be more careful. We must proceed step by step as in the constructions in Lemmas 7.2 and 7.4. Suppose first,  $\sigma$  intersects only one curve  $\alpha$ , belonging to a  $B$ -partition, but not a moduli curve. Then  $\alpha$  is the boundary curve of two adjacent surfaces of type  $(0; 3)$ , the rest of whose boundary curves belong to the partition.  $\sigma$  is then a twist curve on the union of these surfaces and we can again apply Lemma 9.1 to conclude that the trace of the element corresponding to  $\alpha$  tends to 2.

If  $\sigma$  intersects more than one such nonmoduli,  $B$ -partition curve  $\alpha$ , we proceed through the refinements of the  $B$ -partition as described in §7 until we reach one where  $\sigma$  intersects only one such curve  $\alpha$ . We now apply the above argument. Q.E.D.

**REMARK 9.1.** It is clear that the condition on the boundary moduli is necessary because all control on the area, diameter, collars, etc., disappears when the boundary elements are arbitrarily long.

## BIBLIOGRAPHY

1. L. Bers, *On moduli of Riemann surfaces*, Lecture Notes, Eidgenössische Technische Hochschule, Zürich, 1964 (mimeographed).

2. ———, *Spaces of degenerating Riemann surfaces*, Discontinuous Groups and Riemann Surfaces, Princeton Univ. Press, Princeton, N. J., 1974, pp. 43–55. MR 50 #13497.

3. ———, *On boundaries of Teichmüller spaces and on kleinian groups*. I, Ann. of Math. (2) 91 (1970), 570–600. MR 45 #7044.

4. J. S. Birman and H. M. Hilden, *On the mapping class groups of closed surfaces as covering spaces*, Advances in the Theory of Riemann Surfaces, Princeton Univ. Press, Princeton, N. J., 1971, pp. 81–115. MR 45 #1169.

5. J. S. Birman, *Braids, links, and mapping class groups*, Princeton Univ. Press, Princeton, N. J.; Univ. of Tokyo Press, Tokyo, 1974. MR 51 #11477.

6. M. Dehn, *Die Gruppe der Abbildungsklassen*, Acta Math. 69 (1938), 135–206.

7. W. Fenchel and J. Nielsen, *On discontinuous groups of motions* (unpublished manuscript).

8. R. Fricke and F. Klein, *Vorlesungen über die Theorie der automorphen Funktionen*, Leipzig, 1926.

9. L. Keen, *Intrinsic moduli on Riemann surfaces*, Ann. of Math. (2) 84 (1966), 404–420. MR 34 #2859.

10. ———, *Canonical polygons for finitely generated Fuchsian groups*, Acta Math. 115 (1965), 1–16. MR 32 #1349.

11. ———, *On Fricke moduli*, Advances in the Theory of Riemann Surfaces, Princeton Univ. Press, Princeton, N. J., 1971, pp. 205–224. MR 44 #5450.

12. ———, *A correction to "On Fricke moduli"*, Proc. Amer. Math. Soc. 40 (1973), 60–62. MR 47 #8845.

13. ———, *Collars on Riemann surfaces*, Discontinuous Groups and Riemann Surfaces, Princeton Univ. Press, Princeton, N. J., 1974, pp. 263–268. MR 52 #738.

14. ———, *On fundamental domains and the Teichmüller modular group*, Contributions to Analysis, Academic Press, New York and London, 1974, pp. 185–194. MR 51 #885.

15. ———, *A modular group and Riemann surfaces of genus 2*, Math. Z. 142 (1975), 205–219. MR 51 #8404.

16. W. Magnus, A. Karass and D. Solitar, *Combinatorial group theory*, Interscience, New York and London, 1966. MR 34 #7617.

17. B. Maskit, *Construction of Kleinian groups*, Proc. Conf. on Complex Analysis, Springer-Verlag, Berlin and New York, 1965, pp. 281–296. MR 31 #2396.

18. ———, *On Klein's combination theorem*, Trans. Amer. Math. Soc. 120 (1965), 499–509. MR 23 #274.

19. ———, *On boundaries of Teichmüller spaces and on kleinian groups*. II, Ann. of Math. (2) 91 (1970), 607–639. MR 45 #7045.

20. J. P. Matelsky, *A compactness theorem for Fuchsian groups of the second kind*, Duke Math. J. (to appear).

21. D. Mumford, *A remark on Mahler's compactness theorem*, Proc. Amer. Math. Soc. 28 (1971), 289–294. MR 43 #2157.

22. J. Nielsen, *Die isomorphismen der allgemeinen unendlichen Gruppe mit zwei Erzeugenden*, Math. Ann. 78 (1918), 385–397.

23. ———, *Untersuchungen zur Topologie der geschlossenen zweiseitigen Flächen*. I, II, III, Acta Math. 50 (1927), 189–358; *ibid.* 53 (1929), 1–76; *ibid.* 87 (1932), 87–167.

24. H. Poincaré, *Theorie des groupes Fuchsians*, Acta Math. 1 (1882), 1–62.

DEPARTMENT OF MATHEMATICS, LEHMAN COLLEGE AND THE GRADUATE CENTER OF THE CITY UNIVERSITY OF NEW YORK, NEW YORK, NEW YORK 10036