

GENERATING THE EXTENDED MAPPING CLASS GROUP BY THREE INVOLUTIONS

TÜLİN ALTUNÖZ, MEHMETÇİK PAMUK and OĞUZ YILDIZ

(Received October 27, 2020, revised September 22, 2021)

Abstract

We prove that the extended mapping class group, $\text{Mod}^*(\Sigma_g)$, of a connected orientable surface of genus g , can be generated by three involutions for $g \geq 5$. In the presence of punctures, we prove that $\text{Mod}^*(\Sigma_{g,p})$ can be generated by three involutions for $g \geq 10$ and $p \geq 6$ (with the exception that for $g \geq 11$, p should be at least 15).

1. Introduction

Let $\Sigma_{g,p}$ denote a connected orientable surface of genus g with $p \geq 0$ punctures. When $p = 0$, we drop it from the notation and write Σ_g . The mapping class group of Σ_g is the group of isotopy classes of orientation preserving diffeomorphisms and is denoted by $\text{Mod}(\Sigma_g)$. It is a classical result that $\text{Mod}(\Sigma_g)$ is generated by finitely many Dehn twists about nonseparating simple closed curves [4, 9, 14]. The study of algebraic properties of mapping class group, finding small generating sets, generating sets with particular properties, is an active one leading to interesting developments. Wajnryb [23] showed that $\text{Mod}(\Sigma_g)$ can be generated by two elements given as a product of Dehn twists. As the group is not abelian, this is the smallest possible. Korkmaz [11] improved this result by first showing that one of the two generators can be taken as a Dehn twist and the other as a torsion element. He also proved that $\text{Mod}(\Sigma_g)$ can be generated by two torsion elements. Recently, the third author showed that $\text{Mod}(\Sigma_g)$ is generated by two torsions of small orders [24].

Generating $\text{Mod}(\Sigma_g)$ by involutions was first considered by McCarthy and Papadopoulos [17]. They showed that the group can be generated by infinitely many conjugates of a single involution (element of order two) for $g \geq 3$. In terms of generating by finitely many involutions, Luo [16] showed that any Dehn twist about a nonseparating simple closed curve can be written as a product six involutions, which in turn implies that $\text{Mod}(\Sigma_g)$ can be generated by $12g + 6$ involutions. Brendle and Farb [2] obtained a generating set of six involutions for $g \geq 3$. Following their work, Kassabov [10] showed that $\text{Mod}(\Sigma_g)$ can be generated by four involutions if $g \geq 7$. Recently, Korkmaz [12] showed that $\text{Mod}(\Sigma_g)$ is generated by three involutions if $g \geq 8$ and four involutions if $g \geq 3$. The third author improved these results by showing that this group can be generated by three involutions if $g \geq 6$ [25].

The extended mapping class group $\text{Mod}^*(\Sigma_g)$ is defined to be the group of isotopy classes of all self-diffeomorphisms of Σ_g . The mapping class group $\text{Mod}(\Sigma_g)$ is an index two normal subgroup of $\text{Mod}^*(\Sigma_g)$. In [11], it is proved that $\text{Mod}^*(\Sigma_g)$ can be generated by two

elements, one of which is a Dehn twist. Moreover, it follows from [11, Theorem 14] that $\text{Mod}^*(\Sigma_g)$ can be generated by three torsion elements for $g \geq 1$. Also, Du [5, 6] proved that $\text{Mod}^*(\Sigma_g)$ can be generated by two torsion elements of order 2 and $4g+2$ for $g \geq 3$. In terms of involution generators, as it contains nonabelian free groups, the minimal number of involution generators is three and Stukow [22] proved that $\text{Mod}^*(\Sigma_g)$ can be generated by three involutions for $g \geq 1$. Although our main interest in this paper is to find minimal generating sets for the extended mapping class group in the presence of punctures, in Section 3, we test our techniques to find minimal generating sets of involutions. In this direction, we obtain the following result (see Theorems 3.2 and 3.3):

Theorem A. *For $g \geq 5$, the extended mapping class group $\text{Mod}^*(\Sigma_g)$ can be generated by three involutions.*

In the presence of punctures, the mapping class group $\text{Mod}(\Sigma_{g,p})$ is defined to be the group of isotopy classes of orientation-preserving self-diffeomorphisms of $\Sigma_{g,p}$ preserving the set of punctures. The extended mapping class group $\text{Mod}^*(\Sigma_{g,p})$ is defined as the group of isotopy classes of all (including orientation-reversing) self-diffeomorphisms of $\Sigma_{g,p}$ that preserve the set of punctures. Kassabov [10] gave involution generators of $\text{Mod}(\Sigma_{g,p})$, proving that this group can be generated by four involutions if $g > 7$ or $g = 7$ and p is even, five involutions if $g > 5$ or $g = 5$ and p is even, six involutions if $g > 3$ or $g = 3$ and p is even (Allowing orientation reversing involutions these results can also be used for $\text{Mod}^*(\Sigma_{g,p})$ [10, Remark 3]). Later, Monden [18] removed the parity conditions on the number of punctures. For $g \geq 1$ and $p \geq 2$, he [19] also proved that $\text{Mod}(\Sigma_{g,p})$ can be generated by three elements, one of which is a Dehn twist. Moreover, he gave a similar generating set for $\text{Mod}^*(\Sigma_{g,p})$ consisting of three elements. Recently, Monden showed that $\text{Mod}(\Sigma_{g,p})$ and $\text{Mod}^*(\Sigma_{g,p})$ are generated by two elements [20].

In Section 4, we prove the following result, giving a partial answer to Question 5.6 of [18].

Theorem B. *For $g \geq 10$ and $p \geq 6$ (with the exception that for $g \geq 11$, p should be at least 15), the extended mapping class group $\text{Mod}^*(\Sigma_{g,p})$ can be generated by three involutions.*

REMARK. At the end of the paper, we also show that the same result holds for $g \geq 10$ and $p = 1, 2, 3$.

Before we finish the introduction, let us point out that by the version of Dehn-Nielsen-Baer theorem for punctured surfaces (see [7, Section 8.2.7]), $\text{Mod}^*(\Sigma_{g,p})$ is isomorphic to the subgroup of the outer automorphism group $\text{Out}(\pi_1(\Sigma_{g,p}))$ consisting of elements that preserve the set of conjugacy classes of the simple closed curves surrounding individual punctures. Note also that these conjugacy classes are precisely the primitive conjugacy classes that correspond to the parabolic elements of the group of isometries of the hyperbolic plane.

2. Background and Results on Mapping Class Groups

Let $\Sigma_{g,p}$ be a connected orientable surface of genus g with p punctures specified by the set $P = \{z_1, z_2, \dots, z_p\}$ of p distinguished points. If p is zero then we omit from the notation.

The mapping class group $\text{Mod}(\Sigma_{g,p})$ of the surface $\Sigma_{g,p}$ is defined to be the group of the isotopy classes of orientation preserving diffeomorphisms $\Sigma_{g,p} \rightarrow \Sigma_{g,p}$ which fix the set P . The extended mapping class group $\text{Mod}^*(\Sigma_{g,p})$ of the surface $\Sigma_{g,p}$ is defined to be the group of isotopy classes of all (including orientation-reversing) diffeomorphisms of $\Sigma_{g,p}$ which fix the set P . Let $\text{Mod}_0^*(\Sigma_{g,p})$ denote the subgroup of $\text{Mod}^*(\Sigma_{g,p})$ which consists of elements fixing the set P pointwise. It is obvious that we have the exact sequence:

$$1 \longrightarrow \text{Mod}_0^*(\Sigma_{g,p}) \longrightarrow \text{Mod}^*(\Sigma_{g,p}) \longrightarrow S_p \longrightarrow 1,$$

where S_p denotes the symmetric group on the set $\{1, 2, \dots, p\}$ and the restriction of the isotopy class of a diffeomorphism to its action on the puncture points gives the last projection.

Let $\beta_{i,j}$ be an embedded arc joining two punctures z_i and z_j and not intersecting δ on $\Sigma_{g,p}$. Let $D_{i,j}$ be a closed regular neighbourhood of $\beta_{i,j}$ such that it is a disk with two punctures. There is a diffeomorphism $H_{i,j} : D_{i,j} \rightarrow D_{i,j}$, which interchanges the punctures such that $H_{i,j}^2$ is the right handed Dehn twist about $\partial D_{i,j}$ and is equal to the identity on the complement of the interior of $D_{i,j}$. Such a diffeomorphism is called *the (right handed) half twist* about $\beta_{i,j}$. One can extend it to a diffeomorphism of $\text{Mod}(\Sigma_{g,p})$. Throughout the paper we do not distinguish a diffeomorphism from its isotopy class. For the composition of two diffeomorphisms, we use the functional notation; if g and h are two diffeomorphisms, then the composition gh means that h is applied first.

For a simple closed curve a on $\Sigma_{g,p}$, following [1, 12] the right-handed Dehn twist t_a about a will be denoted by the corresponding capital letter A .

Now, let us recall the following basic properties of Dehn twists which we use frequently in the remaining of the paper. Let a and b be simple closed curves on $\Sigma_{g,p}$ and $f \in \text{Mod}^*(\Sigma_{g,p})$.

- **Commutativity:** If a and b are disjoint, then $AB = BA$.
- **Conjugation:** If $f(a) = b$, then $fAf^{-1} = B^s$, where $s = \pm 1$ depending on whether f is orientation preserving or orientation reversing on a neighbourhood of a with respect to the chosen orientation.

3. Involution generators for $\text{Mod}^*(\Sigma_g)$

We start with this section by embedding Σ_g into \mathbb{R}^3 so that it is invariant under the reflections ρ_1 and ρ_2 (see Figures 1 and 2). Here, ρ_1 and ρ_2 are the reflections in the xz -plane so that $R = \rho_1\rho_2$ is the rotation by $\frac{2\pi}{g}$ about the x -axis. Now, let us recall the following set of generators given by Korkmaz [12, Theorem 5].

Theorem 3.1. *If $g \geq 3$, then the mapping class group $\text{Mod}(\Sigma_g)$ is generated by the four elements $R, A_1A_2^{-1}, B_1B_2^{-1}, C_1C_2^{-1}$.*

By adding an orientation reversing self-diffeomorphism to the above generating set, one can easily see that $\text{Mod}^*(\Sigma_g)$ can be generated by five elements. In the following theorems, we show that one can reduce the number of generators to three and all the generators are of order two.

Theorem 3.2. *If $g \geq 5$ and odd, then $\text{Mod}^*(\Sigma_g)$ is generated by the involutions ρ_1, ρ_2 and $\rho_1A_1B_2C_{\frac{g+3}{2}}A_3$.*

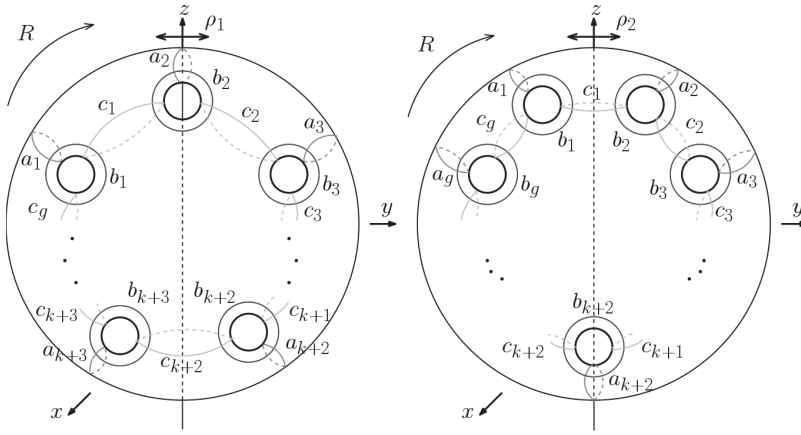

Fig.1. The reflections ρ_1 and ρ_2 on Σ_g if $g = 2k + 1$.

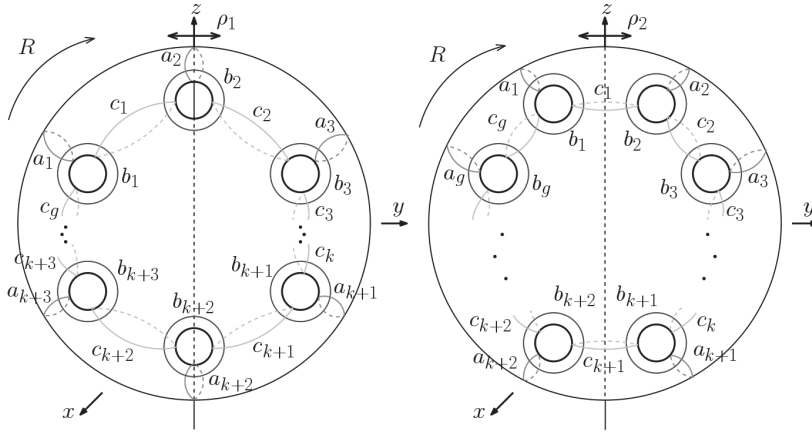

Fig.2. The reflections ρ_1 and ρ_2 on Σ_g if $g = 2k$.

Proof. Consider the surface Σ_g as in Figure 1 and observe that the involution ρ_1 satisfies

$$\rho_1(a_1) = a_3, \rho_1(b_2) = b_2 \text{ and } \rho_1(c_{\frac{g+3}{2}}) = c_{\frac{g+3}{2}}.$$

Since ρ_1 reverses the orientation of a neighbourhood of any simple closed curve, we get

$$\rho_1 A_1 \rho_1 = A_3^{-1}, \rho_1 B_2 \rho_1 = B_2^{-1} \text{ and } \rho_1 C_{\frac{g+3}{2}} \rho_1 = C_{\frac{g+3}{2}}^{-1}.$$

It is easily seen that $\rho_1 A_1 B_2 C_{\frac{g+3}{2}} A_3$ is an involution. Let K be the subgroup of $\text{Mod}^*(\Sigma_g)$ generated by the set

$$\{\rho_1, \rho_2, \rho_1 A_1 B_2 C_{\frac{g+3}{2}} A_3\}.$$

Note that the rotation R and the orientation reversing diffeomorphism ρ_1 (or ρ_2) are contained in K . Hence, all we need to show is that the elements $A_1 A_2^{-1}, B_1 B_2^{-1}$ and $C_1 C_2^{-1}$ belong to K . For $g \geq 7$ and odd, by proof of [1, Theorem 3.4], these elements are contained in K . For $g = 5$, the proof follows from the proof of [1, Theorem 3.3]. \square

Next, we deal with the even genera case.

Theorem 3.3. *If $g \geq 6$ and even, then $\text{Mod}^*(\Sigma_g)$ is generated by the involutions ρ_1 , ρ_2 and $\rho_1 A_2 C_{\frac{g}{2}} B_{\frac{g+4}{2}} C_{\frac{g+6}{2}}$.*

Proof. Consider the surface Σ_g as in Figure 2 when $g \geq 6$ and even. The involution ρ_1 satisfies

$$\rho_1(a_2) = a_2, \rho_1(b_{\frac{g+4}{2}}) = b_{\frac{g+4}{2}} \text{ and } \rho_1(c_{\frac{g}{2}}) = c_{\frac{g+6}{2}}.$$

Since ρ_1 reverses the orientation of a neighbourhood of any simple closed curve, we have

$$\rho_1 A_2 \rho_1 = A_2^{-1}, \rho_1 B_{\frac{g+4}{2}} \rho_1 = B_{\frac{g+4}{2}}^{-1} \text{ and } \rho_1 C_{\frac{g}{2}} \rho_1 = C_{\frac{g+6}{2}}^{-1}.$$

It can be shown that $\rho_1 A_2 C_{\frac{g}{2}} B_{\frac{g+4}{2}} C_{\frac{g+6}{2}}$ is an involution. Let H be the subgroup of $\text{Mod}^*(\Sigma_g)$ generated by the set

$$\{\rho_1, \rho_2, \rho_1 A_2 C_{\frac{g}{2}} B_{\frac{g+4}{2}} C_{\frac{g+6}{2}}\}.$$

Note that the rotation R is in H . Since H contains the orientation reversing diffeomorphism ρ_1 (or ρ_2), again all we need to show is that the elements $A_1 A_2^{-1}$, $B_1 B_2^{-1}$ and $C_1 C_2^{-1}$ are contained in H . By the proof of [1, Theorem 3.5], these elements are contained in H . \square

4. Involution generators for $\text{Mod}^*(\Sigma_{g,p})$

In this section, we introduce punctures on a genus g surface and present involution generators for the extended mapping class group $\text{Mod}^*(\Sigma_{g,p})$. First, we recall the following basic lemma from algebra.

Lemma 4.1. *Let G and K be groups, Suppose that we have the following short exact sequence holds,*

$$1 \longrightarrow N \xrightarrow{i} G \xrightarrow{\pi} K \longrightarrow 1.$$

Then the subgroup H contains $i(N)$ and has a surjection to K if and only if $H = G$.

For $G = \text{Mod}^*(\Sigma_{g,p})$ and $N = \text{Mod}_0^*(\Sigma_{g,p})$ (self-diffeomorphisms fixing the punctures pointwise), we have the following short exact sequence:

$$1 \longrightarrow \text{Mod}_0^*(\Sigma_{g,p}) \longrightarrow \text{Mod}^*(\Sigma_{g,p}) \longrightarrow S_p \longrightarrow 1,$$

where S_p denotes the symmetric group on the set $\{1, 2, \dots, p\}$. Therefore, we have the following useful result which follows immediately from Lemma 4.1. Let H be a subgroup of $\text{Mod}^*(\Sigma_{g,p})$. If the subgroup H contains $\text{Mod}_0^*(\Sigma_{g,p})$ and has a surjection to S_p then $H = \text{Mod}^*(\Sigma_{g,p})$.

In the presence of punctures, we consider the reflections ρ_1 and ρ_2 as shown in Figures 3, 4, 5 and 6. Note that the element $R = \rho_1 \rho_2$ is contained in $\text{Mod}^*(\Sigma_{g,p})$ and we have

- $R(a_i) = a_{i+1}$, $R(b_i) = b_{i+1}$ for $i = 1, \dots, g-1$ and $R(b_g) = b_1$,
- $R(c_i) = c_{i+1}$ for $i = 1, \dots, g-2$,
- $R(z_1) = z_p$ and $R(z_i) = z_{i-1}$ for $i = 2, \dots, p$.

In the proof of the following lemmata, we basically follow Theorem 3.1.

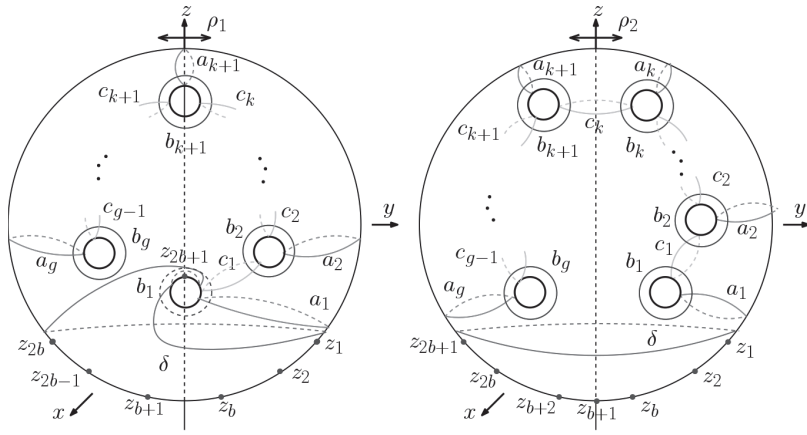

Fig.3. The reflections ρ_1 and ρ_2 if $g = 2k$ and $p = 2b + 1$.

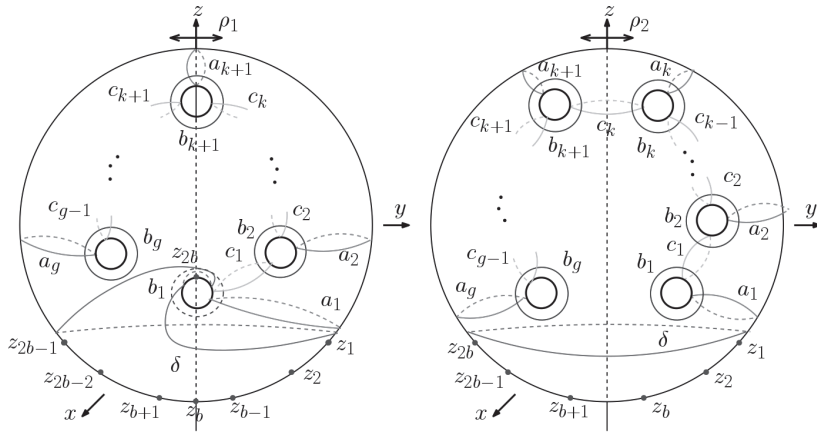

Fig.4. The reflections ρ_1 and ρ_2 if $g = 2k$ and $p = 2b$.

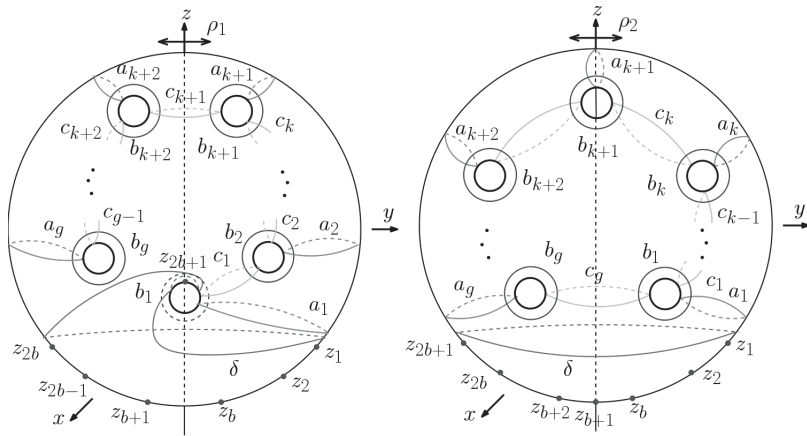

Fig.5. The reflections ρ_1 and ρ_2 if $g = 2k + 1$ and $p = 2b + 1$.

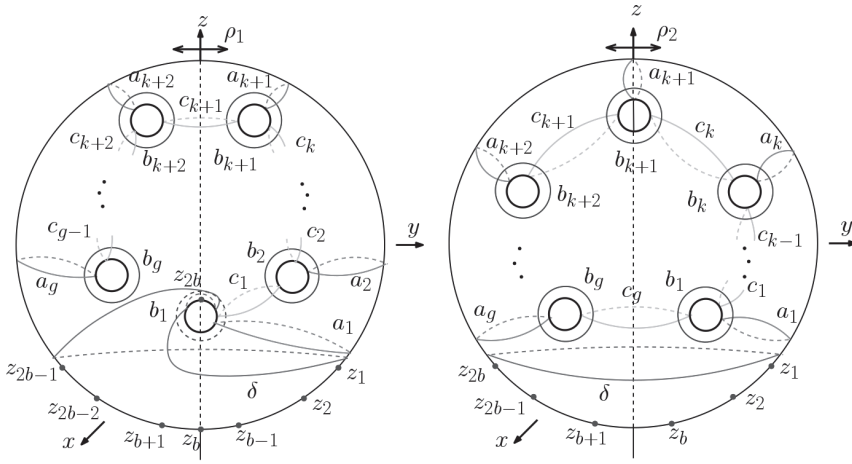

Fig. 6. The reflections ρ_1 and ρ_2 if $g = 2k + 1$ and $p = 2b$.

Lemma 4.2. For $g = 2k \geq 10$, the subgroup H of $\text{Mod}^*(\Sigma_{g,p})$ generated by

$$\begin{cases} \rho_1, \rho_2, \rho_2 H_{b,b+2} B_{k-3} A_{k-1} C_k A_{k+2} B_{k+4} & \text{if } p = 2b + 1 \geq 7, \\ \rho_1, \rho_2, \rho_2 H_{b,b+1} B_{k-3} A_{k-1} C_k A_{k+2} B_{k+4} & \text{if } p = 2b \geq 6 \end{cases}$$

contains the Dehn twists A_i , B_i and C_j for $i = 1, \dots, g$ and $j = 1, \dots, g - 1$.

Proof. Consider the models for $\Sigma_{g,p}$ as shown in Figures 3 and 4. Start with the case $p = 2b + 1$. Let $E_1 := H_{b,b+2} B_{k-3} A_{k-1} C_k A_{k+2} B_{k+4}$ so that the subgroup H is generated by the elements ρ_1 , ρ_2 and $\rho_2 E_1$. Since H contains the elements ρ_1 , ρ_2 and $\rho_2 E_1$, it follows that H also contains the elements $R = \rho_1 \rho_2$ and $E_1 = \rho_2 \rho_2 E_1$.

Let E_2 denote the conjugation of E_1 by R^{-1} . Since

$$R^{-1}(b_{k-3}, a_{k-1}, c_k, a_{k+2}, b_{k+4}) = (b_{k-4}, a_{k-2}, c_{k-1}, a_{k+1}, b_{k+3})$$

and

$$R^{-1}(z_b, z_{b+2}) = (z_{b+1}, z_{b+3}),$$

it follows that $E_2 = R^{-1} E_1 R = H_{b+1,b+3} B_{k-4} A_{k-2} C_{k-1} A_{k+1} B_{k+3} \in H$. Let E_3 be the conjugation of E_2 by R^3 . Since the element R^3 satisfies

$$R^3(b_{k-4}, a_{k-2}, c_{k-1}, a_{k+1}, b_{k+3}) = (b_{k-1}, a_{k+1}, c_{k+2}, a_{k+4}, b_{k+6})$$

and

$$R^3(z_{b+1}, z_{b+3}) = (z_{b-2}, z_b),$$

the element

$$E_3 = R^3 E_2 R^{-3} = H_{b-2,b} B_{k-1} A_{k+1} C_{k+2} A_{k+4} B_{k+6} \in H.$$

Consider the element $E_4 = (E_2 E_3) E_2 (E_2 E_3)^{-1}$, which is contained in H . Thus,

$$E_4 = H_{b+1,b+3} B_{k-4} A_{k-2} B_{k-1} A_{k+1} C_{k+2}$$

As we have similar cases in the remaining parts of the paper, let us explain this calculation in more details. It is easy to verify that the diffeomorphism E_2E_3 maps the curves $\{b_{k-4}, a_{k-2}, c_{k-1}, a_{k+1}, b_{k+3}\}$ to the curves $\{b_{k-4}, a_{k-2}, b_{k-1}, a_{k+1}, c_{k+2}\}$, respectively. Since the half twists $H_{b+1, b+3}$ and $H_{b-2, b}$ commute, we get

$$\begin{aligned} E_4 &= (E_2E_3)E_2(E_2E_3)^{-1} \\ &= (E_2E_3)(H_{b+1, b+3}B_{k-4}A_{k-2}C_{k-1}A_{k+1}B_{k+3})(E_2E_3)^{-1} \\ &= H_{b+1, b+3}B_{k-4}A_{k-2}B_{k-1}A_{k+1}C_{k+2}. \end{aligned}$$

We also get the element

$$E_5 = RE_4R^{-1} = H_{b, b+2}B_{k-3}A_{k-1}B_kA_{k+2}C_{k+3} \in H.$$

Hence the subgroup H contains the element

$$E_6 = E_1E_5^{-1} = C_kB_{k+4}C_{k+3}^{-1}B_k^{-1}.$$

Moreover, we have the following elements:

$$\begin{aligned} E_7 &= RE_5R^{-1} = H_{b-1, b+1}B_{k-2}A_kB_{k+1}A_{k+3}C_{k+4}, \\ E_8 &= R^{-3}E_7R^3 = H_{b+2, b+4}B_{k-5}A_{k-3}B_{k-2}A_kC_{k+1} \text{ and} \\ E_9 &= (E_7E_8)E_7(E_7E_8)^{-1} = H_{b-1, b+1}B_{k-2}A_kC_{k+1}A_{k+3}C_{k+4}, \end{aligned}$$

are contained in H . Thus, we obtain the element $E_7E_9^{-1} = B_{k+1}C_{k+1}^{-1} \in H$. By conjugating $B_{k+1}C_{k+1}^{-1}$ with powers of R , we have $B_iC_i^{-1} \in H$ for all $i = 1, \dots, g-1$. Moreover, the element $E_6(B_kC_k^{-1}) = B_{k+4}C_{k+3}^{-1}$ is contained in H . Thus, each $B_{i+1}C_i^{-1}$ is in H for all $i = 1, \dots, g-1$ by conjugating this element with powers of R . Consider the elements

$$\begin{aligned} E_{10} &= (B_kC_k^{-1})(B_{k+5}C_{k+4}^{-1})(C_{k+4}B_{k+4}^{-1})E_1 \\ &= H_{b, b+2}B_{k-3}A_{k-1}B_kA_{k+2}B_{k+5}, \\ E_{11} &= R^{-1}E_{10}R = H_{b+1, b+3}B_{k-4}A_{k-2}B_{k-1}A_{k+1}B_{k+4} \\ E_{12} &= R^3E_{11}R^{-3} = H_{b-2, b}B_{k-1}A_{k+1}B_{k+2}A_{k+4}B_{k+7} \text{ and} \\ E_{13} &= (E_{11}E_{12})E_{11}(E_{11}E_{12})^{-1} = H_{b+1, b+3}B_{k-4}A_{k-2}B_{k-1}A_{k+1}A_{k+4}, \end{aligned}$$

which are contained in H . Hence, H contains the element $E_{13}E_{11}^{-1} = A_{k+4}B_{k+4}^{-1}$. Hence, $A_iB_i^{-1} \in H$ for $i = 1, \dots, g$, by conjugating $A_{k+4}B_{k+4}^{-1}$ with powers of R . Finally, we obtain the following elements:

$$\begin{aligned} A_1A_2^{-1} &= (A_1B_1^{-1})(B_1C_1^{-1})(C_1B_2^{-1})(B_2A_2^{-1}), \\ B_1B_2^{-1} &= (B_1C_1^{-1})(C_1B_2^{-1}) \text{ and} \\ C_1C_2^{-1} &= (C_1B_2^{-1})(B_2C_2^{-1}), \end{aligned}$$

which are all contained in H . This completes the proof for $p = 2b + 1 \geq 7$ by Theorem 3.1.

For $p = 2b \geq 6$, one can replace $H_{b, b+2}$ with $H_{b, b+1}$ and follow exactly the same steps as above. \square

Lemma 4.3. For $g = 2k + 1 \geq 13$, the subgroup H of $\text{Mod}^*(\Sigma_{g,p})$ generated by

$$\begin{cases} \rho_1, \rho_2, \rho_2 H_{b,b+2} A_{k-1} C_{k-3} B_{k+1} C_{k+4} A_{k+3} & \text{if } p = 2b + 1 \geq 7, \\ \rho_1, \rho_2, \rho_2 H_{b,b+1} A_{k-1} C_{k-3} B_{k+1} C_{k+4} A_{k+3} & \text{if } p = 2b \geq 6 \end{cases}$$

contains the Dehn twists A_i , B_i and C_j for $i = 1, \dots, g$ and $j = 1, \dots, g - 1$.

Proof. Consider the models for $\Sigma_{g,p}$ as shown in Figures 5 and 6. First let us consider the case $p = 2b + 1$. Let $F_1 = H_{b,b+2} A_{k-1} C_{k-3} B_{k+1} C_{k+4} A_{k+3}$ so that the subgroup H generated by the elements ρ_1 , ρ_2 and $\rho_2 F_1$. It follows from H contains the elements ρ_1 , ρ_2 and $\rho_2 F_1$ that H also contains the elements $R = \rho_1 \rho_2$ and $F_1 = \rho_2 \rho_2 F_1$.

Let F_2 denote the conjugation of F_1 by R^{-1} so that

$$F_2 = R^{-1} F_1 R = H_{b+1,b+3} A_{k-2} C_{k-4} B_k C_{k+3} A_{k+2} \in H.$$

and let F_3 be the conjugation of F_2 by R^3 :

$$F_3 = R^3 F_2 R^{-3} = H_{b-2,b} A_{k+1} C_{k-1} B_{k+3} C_{k+6} A_{k+5} \in H.$$

From these, we get the following element:

$$\begin{aligned} F_4 &= (F_2 F_3) F_2 (F_2 F_3)^{-1} \\ &= H_{b+1,b+3} A_{k-2} C_{k-4} C_{k-1} B_{k+3} A_{k+2}, \end{aligned}$$

which is contained in H . Thus, the subgroup H contains the element

$$F_5 = F_4 F_2^{-1} = C_{k-1} B_{k+3} C_{k+3}^{-1} B_k^{-1}.$$

Also we get the following elements:

$$\begin{aligned} F_6 &= R^3 F_4 R^{-3} = H_{b-2,b} A_{k+1} C_{k-1} C_{k+2} B_{k+6} A_{k+5} \text{ and} \\ F_7 &= (F_4 F_6) F_4 (F_4 F_6)^{-1} = H_{b+1,b+3} A_{k-2} C_{k-4} C_{k-1} C_{k+2} A_{k+2}, \end{aligned}$$

which are contained in H . Hence, we see that the element $F_7 F_4^{-1} = C_{k+2} B_{k+3}^{-1} \in H$, which implies that $C_i B_{i+1}^{-1} \in H$ for all $i = 1, \dots, g - 1$ by the action of R . It follows from the element $B_k C_{k-1}^{-1} \in H$ that $F_5 (B_k C_{k-1}^{-1}) = B_{k+3} C_{k+3}^{-1}$ is also contained in H . Similarly we have $B_i C_i^{-1} \in H$ for all $i = 1, \dots, g - 1$ by the action of R . Moreover, the elements

$$\begin{aligned} F_8 &= (B_{k+1} C_k^{-1}) (C_k B_k^{-1}) F_2 \\ &= H_{b+1,b+3} A_{k-2} C_{k-4} B_{k+1} C_{k+3} A_{k+2}, \\ F_9 &= R^3 F_8 R^{-3} = H_{b-2,b} A_{k+1} C_{k-1} B_{k+4} C_{k+6} A_{k+5} \text{ and} \\ F_{10} &= (F_8 F_9) F_8 (F_8 F_9)^{-1} = H_{b+1,b+3} A_{k-2} C_{k-4} A_{k+1} B_{k+4} A_{k+2} \end{aligned}$$

are all in H . Thus H contains the element $F_8 F_{10}^{-1} (B_{k+4} C_{k+3}^{-1}) = B_{k+1} A_{k+1}^{-1}$. Hence, $B_i A_i^{-1} \in H$ for $i = 1, \dots, g$ by conjugating this element with powers of R . The remaining part of the proof can be completed as in the proof of Lemma 4.2. \square

Lemma 4.4. For $g = 11$, the subgroup H of $\text{Mod}^*(\Sigma_{g,p})$ generated by

$$\begin{cases} \rho_1, \rho_2, \rho_1 H_{b,b+1} B_1 A_4 C_6 A_9 & \text{if } p = 2b + 1 \geq 15, \\ \rho_1, \rho_2, \rho_1 H_{b-1,b+1} B_1 A_4 C_6 A_9 & \text{if } p = 2b \geq 16 \end{cases}$$

contains the Dehn twists A_i , B_i and C_j for $i = 1, \dots, g$ and $j = 1, \dots, g - 1$.

Proof. Consider the models for $\Sigma_{g,p}$ as shown in Figures 5 and 6. Let us first consider the case $p = 2b + 1$. Let $G_1 = H_{b,b+1}B_1A_4C_6A_9$ and H be the group generated by the elements ρ_1, ρ_2 and ρ_1G_1 . It is easy to see that H contains the elements $R = \rho_1\rho_2$ and $G_1 = \rho_1\rho_1G_1$. We then have the following elements:

$$\begin{aligned} G_2 &= R^{-3}G_1R^3 = H_{b+3,b+4}B_9A_1C_3A_6, \\ G_3 &= (G_1G_2)G_1(G_1G_2)^{-1} = H_{b,b+1}A_1A_4C_6B_9, \\ G_4 &= R^3G_3R^{-3} = H_{b-3,b-2}A_4A_7C_9B_1, \\ G_5 &= (G_4G_3)G_4(G_4G_3)^{-1} = H_{b-3,b-2}A_4A_7B_9A_1, \\ G_6 &= R^3G_5R^{-3} = H_{b-6,b-5}A_7A_{10}B_1A_4 \text{ and} \\ G_7 &= (G_5G_6)G_5(G_5G_6)^{-1} = H_{b-3,b-2}A_4A_7B_9B_1, \end{aligned}$$

which are all in H . Thus, we obtain the element $G_5G_7^{-1} = A_1B_1^{-1}$. By conjugating by powers of R , we see that $A_iB_i^{-1} \in H$ for $i = 1, 2, \dots, g$. We also have

$$\begin{aligned} G_8 &= (B_4A_4^{-1})G_1 = H_{b,b+1}B_1B_4C_6A_9 \in H, \\ G_9 &= R^{-3}G_8R^3 = H_{b+3,b+4}B_9B_1C_3A_6 \in H \text{ and} \\ G_{10} &= (G_9G_8)G_9(G_9G_8)^{-1} = H_{b+3,b+4}A_9B_1B_4A_6 \in H. \end{aligned}$$

Hence, we get $G_9G_{10}^{-1}(A_9B_9^{-1}) = C_3B_4^{-1} \in H$, which implies that $C_iB_{i+1} \in H$ for $i = 1, 2, \dots, g - 1$ by the action of R . Moreover, the subgroup H contains the following elements:

$$\begin{aligned} G_{11} &= (B_9A_9^{-1})G_1 = H_{b,b+1}B_1A_4C_6B_9, \\ G_{12} &= R^{-3}G_{11}R^3 = H_{b+3,b+4}B_9A_1C_3B_6 \text{ and} \\ G_{13} &= (G_{12}G_{11})G_{12}(G_{12}G_{11})^{-1} = H_{b+3,b+4}B_9B_1C_3C_6. \end{aligned}$$

It follows that $G_{12}G_{13}^{-1}(B_1A_1^{-1}) = B_6C_6^{-1}$. Again, by the action of R , the elements $B_iC_i^{-1} \in H$. One can complete the remaining part of the proof as in the proof of Lemma 4.2. \square

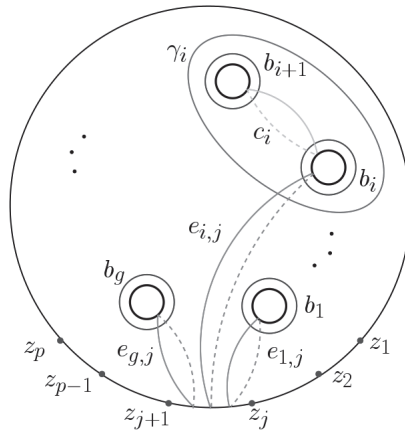

Fig. 7. The curves γ_i and $e_{i,j}$ on the surface $\Sigma_{g,p}$.

Lemma 4.5. *Let $g \geq 2$. For $i = 1, \dots, g-1$, in the mapping class group $\text{Mod}(\Sigma_{g,p})$, the element*

$$\phi_i = B_{i+1}\Gamma_i^{-1}C_iB_i$$

maps the curve $e_{i,j}$ to the curve $e_{i+1,j}$, where the curves γ_i and $e_{i,j}$'s are as in Figure 7. Moreover, the diffeomorphism ϕ_i is contained in the group H for $i = 1, \dots, g-1$.

Proof. It is easy to see that the diffeomorphism ϕ_i maps $e_{i,j}$ to $e_{i+1,j}$. Consider the diffeomorphism

$$S = A_1B_1C_1 \cdots C_{g-2}B_{g-1}C_{g-1}B_g.$$

Since $S \in H$ and S maps a_2 to γ_1 , the element $SA_2S^{-1} = \Gamma_1 \in H$. By conjugating with powers of R , the element Γ_i is in H . We conclude that $\phi_i \in H$. \square

Let H be the subgroup of $\text{Mod}^*(\Sigma_{g,p})$ generated by the elements given explicitly in lemmata 4.2, 4.3 and 4.4 with the conditions mentioned in these lemmata.

Lemma 4.6. *The group $\text{Mod}_0^*(\Sigma_{g,p})$ is contained in the group H .*

Proof. Since the group H contains the Dehn twists $A_1, A_2, B_1, B_2, \dots, B_g$ and C_1, C_2, \dots, C_{g-1} by lemmata 4.2, 4.3 and 4.4, it suffices to prove that H also contains the elements $E_{i,j}$ for some fixed i and $j = 1, 2, \dots, p-1$. First note that H contains A_g and $R = \rho_1\rho_2$. Consider the models for $\Sigma_{g,p}$ as shown in Figures 3, 4, 5 and 6, Since the diffeomorphism R maps a_g to $e_{1,p-1}$, we have

$$RA_gR^{-1} = E_{1,p-1} \in H.$$

The diffeomorphism $\phi_{g-1} \cdots \phi_2\phi_1$ in Lemma 4.5 is given by $\phi_i = B_{i+1}\Gamma_i^{-1}C_iB_i$ which maps each $e_{i,j}$ to $e_{i+1,j}$ for $j = 1, 2, \dots, p-1$ (see Figure 7). So we get

$$\phi_{g-1} \cdots \phi_2\phi_1 E_{1,p-1} (\phi_{g-1} \cdots \phi_2\phi_1)^{-1} = E_{g,p-1} \in H.$$

Similarly, the diffeomorphism R sends $e_{g,p-1}$ to $e_{1,p-2}$. Then we have

$$RE_{g,p-1}R^{-1} = E_{1,p-2} \in H.$$

It follows from

$$\phi_{g-1} \cdots \phi_2\phi_1 E_{1,p-2} (\phi_{g-1} \cdots \phi_2\phi_1)^{-1} = E_{g,p-2} \in H$$

that

$$R(E_{g,p-2})R^{-1} = E_{1,p-3} \in H.$$

Continuing in this way, we conclude that the elements $E_{1,1}, E_{1,2}, \dots, E_{1,p-1}$ are contained in H . This completes the proof. \square

We thank the referee for pointing us the proof of the following lemma.

Lemma 4.7. *The symmetric group S_{2b+1} is generated by the transposition $(b, b+2)$ and the $(2b+1)$ -cycle $(1, 2, \dots, 2b+1)$.*

Proof. Set $\tau = (b, b + 2)$ and $\sigma = (1, 2, \dots, 2b + 1)$. It is easy to verify that

$$\sigma^2 = (1, 3, 5, \dots, 2b + 1, 2, 4, 6, \dots, 2b).$$

Now, rewrite $s_i = 2i - 1$ for $i = 1, 2, \dots, b + 1$ and $s_{b+1+i} = 2i$ for $i = 1, 2, \dots, b$. This gives

$$\sigma^{-b+1}\tau\sigma^{b-1} = (s_1, s_2),$$

$$\sigma^2 = (s_1, s_2, \dots, s_{2b+1}).$$

Since (s_1, s_2) and $(s_1, s_2, \dots, s_{2b+1})$ generate S_{2b+1} , we see that $S_{2b+1} = \langle \tau, \sigma \rangle$. \square

Now, we are ready to prove the main theorem of this section.

Proof of Theorem B. Consider the surface $\Sigma_{g,p}$ as in Figures 3 and 4.

If $g = 2k \geq 10$ and $p \geq 6$: In this case, consider the surface $\Sigma_{g,p}$ as in Figures 3 and 4. Since

$$\rho_2(b_{k-3}) = b_{k+4}, \rho_2(a_{k-1}) = a_{k+2} \text{ and } \rho_2(c_k) = c_k$$

and ρ_2 is an orientation reversing diffeomorphism, we get

$$\rho_2 B_{k-3} \rho_2 = B_{k+4}^{-1}, \rho_2 A_{k-1} \rho_2 = A_{k+2}^{-1} \text{ and } \rho_2 C_k \rho_2 = C_k^{-1}.$$

Also, observe that $\rho_2 H_{b,b+2} \rho_2 = H_{b,b+2}^{-1}$ for $p = 2b + 1$ and $\rho_2 H_{b,b+1} \rho_2 = H_{b,b+1}^{-1}$ for $p = 2b$. Then it is easy to see that each

$$\begin{cases} \rho_2 H_{b,b+2} B_{k-3} A_{k-1} C_k A_{k+2} B_{k+4} & \text{if } p = 2b + 1, \\ \rho_2 H_{b,b+1} B_{k-3} A_{k-1} C_k A_{k+2} B_{k+4} & \text{if } p = 2b \end{cases}$$

is an involution. Therefore, the generators of the subgroup H given in Lemma 4.2 are involutions.

If $g = 2k + 1 \geq 13$ and $p \geq 6$: In this case, consider the surface $\Sigma_{g,p}$ as in Figures 5 and 6. It follows from

$$\rho_2(a_{k-1}) = a_{k+3}, \rho_2(c_{k-3}) = c_{k+4} \text{ and } \rho_2(b_{k+1}) = b_{k+1}$$

and ρ_2 is an orientation reversing diffeomorphism that

$$\rho_2 A_{k-1} \rho_2 = A_{k+3}^{-1}, \rho_2 C_{k-3} \rho_2 = C_{k+4}^{-1} \text{ and } \rho_2 B_{k+1} \rho_2 = B_{k+1}^{-1}.$$

Also, by the fact that $\rho_2 H_{b,b+2} \rho_2 = H_{b,b+2}^{-1}$ for $p = 2b + 1$ and $\rho_2 H_{b,b+1} \rho_2 = H_{b,b+1}^{-1}$ for $p = 2b$, it is easy to see that the elements

$$\begin{cases} \rho_2 H_{b,b+2} A_{k-1} C_{k-3} B_{k+1} C_{k+4} A_{k+3} & \text{if } p = 2b + 1, \\ \rho_2 H_{b,b+1} A_{k-1} C_{k-3} B_{k+1} C_{k+4} A_{k+3} & \text{if } p = 2b \end{cases}$$

are involutions.

If $g = 11$ and $p \geq 15$: Consider the surface $\Sigma_{g,p}$ as in Figures 5 and 6. It is easy to see that

$$\rho_1(b_1) = b_1, \rho_1(a_4) = a_9 \text{ and } \rho_1(c_6) = c_6$$

and ρ_1 is an orientation reversing diffeomorphism that

$$\rho_1 B_1 \rho_1 = B_1^{-1}, \rho_1 A_4 \rho_1 = A_9^{-1} \text{ and } \rho_1 C_6 \rho_1 = C_6^{-1}.$$

Also, since $\rho_1 H_{b,b+1} \rho_1 = H_{b,b+1}^{-1}$ for $p = 2b + 1$ and $\rho_1 H_{b-1,b+1} \rho_1 = H_{b-1,b+1}^{-1}$ for $p = 2b$, it is easy to verify that the elements

$$\begin{cases} \rho_1 H_{b,b+1} B_1 A_4 C_6 A_9 & \text{if } p = 2b + 1, \\ \rho_1 H_{b-1,b+1} B_1 A_4 C_6 A_9 & \text{if } p = 2b \end{cases}$$

are involutions. We see that the generators of the subgroup H given in Lemma 4.4 are involutions.

The group $\text{Mod}_0^*(\Sigma_{g,p})$ is contained in H by Lemma 4.6. We finish the proof by showing that H is mapped surjectively onto S_p by Lemma 4.1: The subgroup H contains the element $\rho_2 \rho_1$ which has the image $(1, 2, \dots, p) \in S_p$. For $g \neq 11$, since the subgroup H contains the Dehn twists A_i, B_i and C_i by lemmata 4.2 and 4.3, the group H contains the half twist $H_{b,b+2}$ if $p = 2b + 1$ and the half twist $H_{b,b+1}$ if $p = 2b$. For $p = 2b + 1$, it follows from Lemma 4.7 that the image of $H_{b,b+2}$ which is $(b, b + 2)$ and the p -cycle $(1, 2, \dots, p)$ generate S_p . For $p = 2b$, it is clear that the image of $H_{b,b+1}$ which is $(b, b + 1)$ and again the p -cycle $(1, 2, \dots, p)$ generate S_p . Likewise, for $g = 11$, by Lemma 4.4, the subgroup H contains the half twist $H_{b,b+1}$ if $p = 2b + 1$, the half twist $H_{b-1,b+1}$ if $p = 2b$. For the latter case H also contains the half twist $R^{-1} H_{b-1,b+1} R = H_{b,b+2}$. This finishes the proof by the above argument.

Before we finish the paper let us mention the cases $p = 2$ or $p = 3$. In these cases, the generating set of H can be chosen as

$$H = \begin{cases} \{\rho_1, \rho_2, \rho_2 B_{k-3} A_{k-1} C_k A_{k+2} B_{k+4}\} & \text{if } g = 2k \geq 10, \\ \{\rho_1, \rho_2, \rho_2 A_{k-1} C_{k-3} B_{k+1} C_{k+4} A_{k+3}\} & \text{if } g = 2k + 1 \geq 13. \\ \{\rho_1, \rho_2, \rho_1 B_1 A_4 C_6 A_9\} & \text{if } g = 11. \end{cases}$$

One can easily prove that the group H contains $\text{Mod}_0^*(\Sigma_{g,p})$ by the similar arguments in the proofs of lemmata 4.3, 4.2, 4.4 and 4.6. The element $\rho_2 \rho_1 \in H$ has the image $(1, 2, \dots, p) \in S_p$. Thus, for $p = 2$ this element generates S_p . If $p = 3$, the element ρ_1 has the image $(1, 2)$. Therefore, the group H is mapped surjectively onto S_p for $p = 2, 3$. We conclude that the group H is equal to $\text{Mod}^*(\Sigma_{g,p})$. \square

ACKNOWLEDGEMENTS. We would like to thank Tara Brendle for her helpful comments. We also would like to thank the referee for carefully reading our manuscript, pointing out an error in an earlier version and suggesting useful ideas which improved the paper. The first author was partially supported by the Scientific and Technological Research Council of Turkey (TÜ Bİ TAK)[grant number 117F015].

References

[1] T. Altunöz, M. Pamuk and O. Yildiz: *Generating the twist subgroup by involutions*, to appear in J. Topol. Anal.

- [2] T.E. Brendle and B. Farb: *Every mapping class group is generated by 6 involutions*, J. Algebra **278** (2004), 187–198.
- [3] D.R.J. Chillingworth: *A finite set of generators for the homeotopy group of a non-orientable surface*, Proc. Cambridge Philos. Soc. **65** (1969), 409–430.
- [4] M. Dehn: *The group of mapping classes*; in Papers on Group Theory and Topology, Springer-Verlag, 1987, Translated from the German by J. Stillwell.
- [5] X. Du: *The extended mapping class group can be generated by two torsions*, J. Knot Theory Ramifications **26** (2017), 1750061, 9pp.
- [6] X. Du: *The torsion generating set of the extended mapping class groups in low genus cases*, Osaka J. Math. **58** (2021), 805–825.
- [7] B. Farb and D. Margalit: *A primer on mapping class groups*, Princeton Mathematical Series **49**, Princeton University Press, Princeton, NJ, 2012.
- [8] S. Gervais: *A finite presentation of the mapping class group of a punctured surface*, Topology **40** (2001), 703–725.
- [9] S. Humphries: *Generators for the mapping class group*; in Topology of Low Dimensional Manifolds, Proc. Second Sussex Conf., Chelwood Gate, (1977), Lecture Notes in Math. **722**, Springer-Verlag, 1979, 44–47.
- [10] M. Kassabov: *Generating mapping class groups by involutions*, arXiv:mathT/0311455.
- [11] M. Korkmaz: *Generating the surface mapping class group by two elements*, Trans. Amer. Math. Soc. **357** (2005), 3299–3310.
- [12] M. Korkmaz: *Mapping class group is generated by three involutions*, Math. Res. Lett. **27** (2020), 1095–1108.
- [13] W.B.R. Lickorish: *Homeomorphisms of non-orientable two manifolds*, Proc. Cambridge Philos. Soc. **59** (1963), 307–317.
- [14] W.B.R. Lickorish: *A finite set of generators for the homeotopy group of a 2-manifold*, Proc. Cambridge Philos. Soc. **60** (1964), 769–778.
- [15] W.B.R. Lickorish: *On the homeomorphisms of a non-orientable surface*, Proc. Cambridge Philos. Soc. **61** (1965), 61–64.
- [16] F. Luo: *Torsion elements in the mapping class group of a surface*, arXiv:math/0004048.
- [17] J.D. McCarthy and A. Papadopoulos: *Involutions in surface mapping class groups*, Enseign. Math. **33** (1987), 275–290.
- [18] N. Monden: *Generating the mapping class group of a punctured surface by involutions*, Tokyo J. Math. **34** (2011), 303–312.
- [19] N. Monden: *The mapping class group of a punctured surface is generated by three elements*, Hiroshima Math. J. **41** (2011), 1–9.
- [20] N. Monden: *On minimal generating sets for the mapping class group of a punctured surface*, arXiv:2103.01525.
- [21] J. Powell: *Two theorems on the mapping class group of a surface*, Proc. Amer. Math. Soc. **68** (1978), 347–350.
- [22] M. Stukow: *The extended mapping class group is generated by 3 symmetries*, C. R. Math. Acad. Sci. Paris **338** (2004), 403–406.
- [23] B. Wajnryb: *Mapping class group of a surface is generated by two elements*, Topology **35** (1996), 377–383.
- [24] O. Yıldız: *Generating mapping class group by two torsion elements*, arXiv:2003.05789.
- [25] O. Yıldız: *Generating mapping class group by three involutions*, arXiv:2002.09151.

Tülin Altunöz

Department of Mathematics, Middle East Technical University
Ankara

Turkey

e-mail: atulin@metu.edu.tr

and

Faculty of Engineering, Başkent University

Ankara

Turkey

e-mail: tulinaltunoz@baskent.edu.tr

Mehmetcik Pamuk

Department of Mathematics, Middle East Technical University
Ankara

Turkey

e-mail: mpamuk@metu.edu.tr

Oğuz Yıldız

Department of Mathematics, Middle East Technical University
Ankara

Turkey

e-mail: oguzyildiz16@gmail.com