

RANK 2 AFFINE MANIFOLDS IN GENUS 3

DAVID AULICINO* & DUC-MANH NGUYEN

Abstract

We complete the classification of rank two affine manifolds in the moduli space of translation surfaces in genus three. Combined with a recent result of Mirzakhani and Wright, this completes the classification of higher rank affine manifolds in genus three.

CONTENTS

1.	Introduction	206
	1.1. Statement of the main result	208
	1.2. Outline	210
2.	Preliminaries	211
	2.1. Unramified double covers	219
3.	A special case of cylinder collapsing	222
4.	Getting four cylinders	225
5.	Four cylinders	231
	5.1. Case 4.IV)	231
	5.2. Case 4.III)	232
	5.3. Case 4.II)	234
	5.4. Case 4.I)	237
6.	Five cylinders	250
	6.1. Case 5.I)	251
	6.2. Case 5.II)	258
	6.3. Proof of Theorem 1.3: Part I	263
7.	Six cylinders	263
	7.1. Proof of Theorem 1.3: Part II	268
	Appendix A. Proof of Lemma 5.6	268
	Appendix B. Proof of Lemma 5.9	273

*D. A. was partially supported by the National Science Foundation under Award Nos. DMS - 1204414, DMS - 1600360, DMS - 1738381 and PSC-CUNY Grant B # 60571-00 48.

Received January 24, 2017.

Appendix C. 6-cylinder diagrams in genus three

276

References

278

1. Introduction

A translation surface is a Riemann surface with a flat geometry given by a holomorphic 1-form on the surface. It is natural to consider the moduli space of translation surfaces, which is the moduli space of Riemann surfaces carrying the bundle of holomorphic 1-forms, also called Abelian differentials. This moduli space admits an action by $\mathrm{SL}_2(\mathbb{R})$. The works of [EM18, EMM15, Fil16] prove that $\mathrm{SL}_2(\mathbb{R})$ orbit closures are *affine submanifolds* admitting a finite ergodic $\mathrm{SL}_2(\mathbb{R})$ -invariant measure, and are also quasi-projective subvarieties of the moduli space of Abelian differentials. However, a complete classification of all quasi-projective subvarieties of moduli space that are $\mathrm{SL}_2(\mathbb{R})$ -invariant is beyond the scope of current techniques. Nevertheless, such a classification was obtained in genus two prior to the aforementioned results [McM07].

The purpose of this paper is to contribute to the classification of the orbit closures in higher genus. Specifically, we complete the classification of rank two affine submanifolds in genus three (see below for a brief introduction to the notion of cylinder rank). Combined with the recent result [MW18, Th. 1.1], a consequence of our result is the following

Theorem A. *Let $M = (X, \omega)$ be a translation surface in a stratum $\mathcal{H}(\kappa)$ in genus three. Then either the closure of the $\mathrm{GL}^+(2, \mathbb{R})$ -orbit of M is one of the following: the component of $\mathcal{H}(\kappa)$ that contains M , the intersection of this component with the hyperelliptic locus, with the Prym locus, or with the intersection of these two loci, or M is completely periodic in the sense of Calta, and the ratio of the circumferences of any pair of parallel cylinders belongs to a finite set.*

The (cylinder) rank of an orbit closure was introduced in [Wri15], and it counts half the degrees of freedom in absolute periods of points (or translation surfaces) in the orbit closure. By definition, the cylinder rank of an orbit closure of surfaces in genus g cannot be greater than g . Any stratum of translation surfaces in genus g is of rank g . On the other hand, closed $\mathrm{SL}_2(\mathbb{R})$ -orbits are examples of rank one affine submanifolds as well as the Prym eigenform loci discovered by [McM06]. Following a result of [Wri15], every surface in a rank one orbit closure is *completely periodic* (in the sense of Calta), meaning that if the surface has a regular closed geodesic in some direction, then any other trajectory in the same direction is either a saddle connection or a closed (regular) geodesic. Orbit closures of rank at least two are said to be of *higher rank*.

The works of [NW14, ANW16, AN16] established the classification of rank two orbit closures in strata in genus three with at most two zeros. This paper exclusively concerns rank two orbit closures in $\mathcal{H}(2, 1, 1)$ and $\mathcal{H}(1, 1, 1, 1)$.

All of the previous works heavily relied on “cylinder proportions” to establish the symmetry required to prove that a translation surface admitted an involution. However, this approach seems to be unrealistic for the last two strata because of the large number of cylinder diagrams that must be analyzed. (There are 190 3-cylinder diagrams, 92 4-cylinder diagrams, and 26 5-cylinder diagrams to consider.¹) On the other hand, for translation surfaces satisfying most cylinder diagrams in a stratum with several zeros, it is possible to deform the surface by collapsing some cylinders to get a translation surface in a lower stratum. We developed new tools based on this observation that rely on [MW17].

While it will be necessary to compute a few cylinder proportions, it is degeneration techniques that will take center stage in the proofs in this paper. A posteriori, all rank two affine manifolds in these two strata contain rank two affine manifolds in lower strata of genus three in their boundary. Eventually, we will show that every surface in any rank two affine manifold in genus three admits a Prym involution (see the definitions below). Some affine manifolds consist exclusively of hyperelliptic Riemann surfaces, that is, they have a hyperelliptic involution in addition to the Prym involution. The existence of those involutions will be established by observing that they exist on the surfaces in the boundary, and with the appropriate assumptions, they can be extended to surfaces in the interior of the affine manifold (see Proposition 2.10). Combined with a dimension count, this allows us to get the complete list of all rank two affine manifolds in the remaining strata.

Another key ingredient is Proposition 2.15, which may be interesting in its own right. This proposition generalizes the results of Masur and Kontsevich-Zorich on the density of the set of Jenkins-Strebel differentials with a single cylinder in any stratum of translation surfaces (see also [Lan08] for related results in the space of quadratic differentials). The essential observation in its proof is the flat surface implication of the result of [EMM15] that the upper triangular orbit closure is equal to the $\mathrm{SL}_2(\mathbb{R})$ orbit closure.

Mirzakhani conjectured that if the rank is at least two, then the orbit closure covers a stratum of Abelian or quadratic differentials. The result of this paper thus confirms the conjecture in genus three. It is also verified in other contexts. In [MW18], Mirzakhani and Wright prove that the only orbit closures of maximal rank are hyperelliptic

¹Computed in Sage using the `surface_dynamics` package. The results in this paper do not rely on any Sage computations.

loci and connected components of the moduli spaces of translation surfaces with specified orders of zeros, known as strata. In [Apl18], it is proven that all higher rank orbit closures in hyperelliptic connected components of strata arise from covering constructions. Though this conjecture is not true in full generality by [MMW17] and forthcoming work of Eskin, McMullen, Mukamel, and Wright, the exceptions appear to be extremely rare.

Together with the result of [MW18], our results complete the classification of higher rank orbit closures in genus three. We hope that this classification facilitates results in genus three concerning higher rank affine manifolds, e.g. [Aul15, Thm. 2.8] follows easily from the main result of this paper and the Forni Geometric Criterion [For11]. Furthermore, we hope that it inspires ideas that lead to classifications in higher genus.

Finally, we remark that we believe that a classification of rank three affine manifolds in genus three should be relatively easy to accomplish using our techniques. However, given the general nature of the result announced in [MW17], we refrain from attempting such a classification with our methods.

1.1. Statement of the main result. Let $M = (X, \omega)$ be a translation surface in genus three. Throughout this paper, by a *Prym involution* of M , we will mean an automorphism τ of the Riemann surface X such that

- a) $\tau^2 = \text{id}_X$,
- b) $\tau^*\omega = -\omega$,
- c) τ has exactly four fixed points in X .

Remark that condition b) means that τ is isometric for the flat metric structure whose derivative is given by $-\text{id}$ at regular points.

Let $Y := X/\langle\tau\rangle$ be the quotient of X by the action of a Prym involution τ . By definition, there exists a double cover $\pi : X \rightarrow Y$ ramified at four points (the fixed points of τ). It follows from the Riemann-Hurwitz formula that Y is a Riemann surface of genus one. Condition b) implies that there exists a meromorphic quadratic differential η on Y such that $\pi^*\eta = \omega^2$.

We will call the subset of $\mathcal{H}_3 = \Omega\mathcal{M}_3$ consisting of surfaces admitting a Prym involution the *Prym locus* and denote it by \mathcal{P} . As usual, the subset of \mathcal{H}_3 consisting of pairs (X, ω) where X is a hyperelliptic surface is called the *hyperelliptic locus*, and we denote it by \mathcal{L} .

Naturally, the intersection of \mathcal{P} with each connected component $\mathcal{H}^*(\kappa)$ of a stratum $\mathcal{H}(\kappa)$ (here $*$ is either “hyp” or “odd”) consists of standard double covers of quadratic differentials in some stratum in genus one.

It follows from Lemma 2.16 below that the intersection $\mathcal{P} \cap \mathcal{L} \subset \mathcal{H}_3$ consists of unramified double covers of translation surfaces in genus two. Actually, it is not difficult to show that any unramified double cover of

a surface in \mathcal{H}_2 must be contained in $\mathcal{P} \cap \mathcal{L}$. Our main result can be stated as follows

Theorem 1.1. *Let \mathcal{M} be a rank two affine submanifold of a connected component of a stratum $\mathcal{H}(\kappa)$ in genus three. Then either \mathcal{M} is a component of $\mathcal{P} \cap \mathcal{H}^*(\kappa)$, or \mathcal{M} is a component of $\mathcal{M} = \mathcal{P} \cap \mathcal{L} \cap \mathcal{H}^*(\kappa)$. In the latter case \mathcal{M} is a locus consisting of unramified double covers of surfaces in a stratum of \mathcal{H}_2 .*

Theorem 1.1 was proved for strata $\mathcal{H}(\kappa)$ such that $|\kappa| \leq 2$ by our previous classifications (see [NW14, ANW16, AN16]). Namely, in $\mathcal{H}(4)$ we have two components $\mathcal{H}^{\text{odd}}(4)$ and $\mathcal{H}^{\text{hyp}}(4)$, the Prym locus does not intersect $\mathcal{H}^{\text{hyp}}(4)$, and $\mathcal{P} \cap \mathcal{H}^{\text{odd}}(4) = \tilde{Q}(3, -1^3)$. The stratum $\mathcal{H}(3, 1)$ does not intersect \mathcal{P} , hence there are no rank two affine submanifolds in $\mathcal{H}(3, 1)$. The stratum $\mathcal{H}(2, 2)$ has two components $\mathcal{H}^{\text{odd}}(2, 2)$ and $\mathcal{H}^{\text{hyp}}(2, 2) \subset \mathcal{L}$. We have

$$\begin{aligned} \mathcal{P} \cap \mathcal{H}^{\text{hyp}}(2, 2) &= \tilde{\mathcal{H}}_{(2,2)}^{\text{hyp}}(2) = \tilde{Q}(1^2, -1^2), \\ \mathcal{P} \cap \mathcal{H}^{\text{odd}}(2, 2) &= \tilde{Q}(4, -1^4), \\ \mathcal{P} \cap \mathcal{L} \cap \mathcal{H}^{\text{odd}}(2, 2) &= \tilde{\mathcal{H}}_{(2,2)}^{\text{odd}}(2). \end{aligned}$$

Remark 1.2. Let M be a surface in $\mathcal{H}(2, 2) \cap \mathcal{P}$. If $M \in \mathcal{H}^{\text{odd}}(2, 2)$, then the Prym involution exchanges the zeros (cone points) of M , but if $M \in \mathcal{H}^{\text{hyp}}(2, 2)$, then the Prym involution fixes each of the zeros of M .

Let $M = (X, \omega)$ be a translation surface that admits a Prym involution τ . Let $M \in \mathcal{H}(2, 1^2)$. Since $\tau^*\omega = -\omega$, the double zero of ω must be fixed, and the two simple zeros must be exchanged by τ . By assumption, τ has three regular fixed points. Therefore, $\mathcal{P} \cap \mathcal{H}(2, 1^2) = \tilde{Q}(2, 1, -1^3)$. If $M \in \mathcal{H}(1^4)$, then τ must exchange two pairs of simple zeros and has four regular fixed points. Therefore, $\mathcal{P} \cap \mathcal{H}(1^4) = \tilde{Q}(2^2, -1^4)$.

Assume in addition that M admits a hyperelliptic involution. Then M is an unramified double cover of a translation surface in genus two by Lemma 2.16. It follows in particular that $M \notin \mathcal{H}(2, 1^2)$. If $M \in \mathcal{H}(1^4)$, then M is an unramified double cover of a surface in $\mathcal{H}(1, 1)$. Denote the locus of such surfaces by $\tilde{\mathcal{H}}(1, 1)$. Then, $\mathcal{P} \cap \mathcal{L} \cap \mathcal{H}(1^4) = \tilde{\mathcal{H}}(1, 1)$. By Proposition 2.17, this locus is a connected affine submanifold of $\mathcal{H}(1^4)$.

Note that the loci $\tilde{Q}(2, 1, -1^3)$ and $\tilde{Q}(2^2, -1^4)$ are connected by a result of Lanneau [Lan08, Th. 1.2]. From the observations above, to prove Theorem 1.1, it suffices to show

Theorem 1.3. *Let \mathcal{M} be a rank two affine submanifold in $\mathcal{H}_3 = \Omega\mathcal{M}_3$.*

- If $\mathcal{M} \subset \mathcal{H}(2, 1^2)$, then $\mathcal{M} = \tilde{Q}(2, 1, -1^3)$,
- If $\mathcal{M} \subset \mathcal{H}(1^4)$, then either $\mathcal{M} = \tilde{Q}(2^2, -1^4)$, or $\mathcal{M} = \tilde{\mathcal{H}}(1, 1)$.

Figure 1 gives the list of all rank two affine manifolds in genus three and the relations between them.

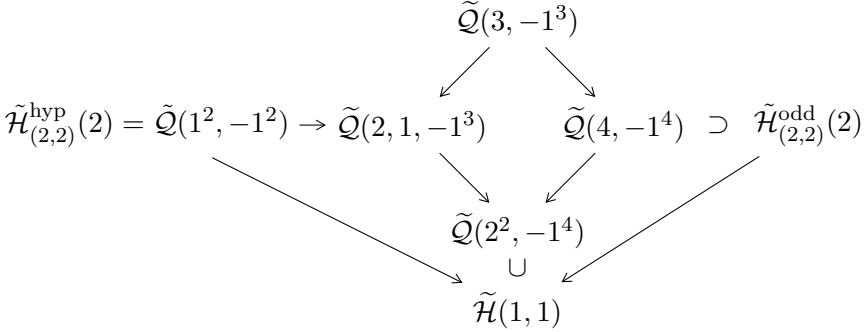

Figure 1. Rank two affine submanifolds of \mathcal{H}_3 : $X \rightarrow Y$ means that $X \subset \partial Y$, and X has codimension 1 in \bar{Y} .

We close this section by indicating how Theorem 1.1 and [MW18, Th. 1.1] imply Theorem A. Let \mathcal{M} be the closure of $\mathrm{GL}^+(2, \mathbb{R}) \cdot M$ in $\mathcal{H}(\kappa)$. If \mathcal{M} is of rank three (that is of full rank), then by [MW18, Th. 1.1], \mathcal{M} is a component of $\mathcal{H}(\kappa)$ or a component of $\mathcal{H}(\kappa) \cap \mathcal{L}$. If \mathcal{M} is of rank two, then by Theorem 1.1, \mathcal{M} is a component of $\mathcal{H}(\kappa) \cap \mathcal{P}$ or a component of $\mathcal{H}(\kappa) \cap \mathcal{P} \cap \mathcal{L}$. Finally, if \mathcal{M} is of rank one, then M must be completely periodic by [Wri15, Th. 1.5], and the ratio of the circumferences of any pair of parallel cylinders belongs to a finite set by [MW17, Th. 1.4].

1.2. Outline. The paper is organized as follows: in Section 2 we recall essential definitions and important results needed for our proofs. Our strategy is to degenerate surfaces in a given rank two affine manifold $\mathcal{M} \subset \mathcal{H}(2, 1^2) \cup \mathcal{H}(1^4)$ by collapsing a family of \mathcal{M} -parallel cylinders, to get surfaces in another rank two affine manifold \mathcal{M}' contained in some lower stratum. The key point is that in some situations, we have $\dim \mathcal{M} = \dim \mathcal{M}' + 1$ (see Propositions 2.8 and 2.9). Moreover, we can derive some important properties of surfaces in \mathcal{M} , namely the existence of involutory automorphisms, from the properties of surfaces in \mathcal{M}' (see Proposition 2.10). We will also prove that the intersection $\mathcal{P} \cap \mathcal{L}$ in \mathcal{H}_3 is precisely the locus of unramified double covers of translation surfaces of genus two (see Lemma 2.16). In [AN16], we showed that $\mathcal{H}(2)$ gives rise to two loci of unramified double covers in \mathcal{H}_3 , namely $\tilde{\mathcal{H}}_{(2,2)}^{\mathrm{odd}}(2)$ and $\tilde{\mathcal{H}}_{(2,2)}^{\mathrm{hyp}}(2)$. Interestingly, we will show that the locus of unramified double covers of surfaces in $\mathcal{H}(1, 1)$ is connected (see Proposition 2.17). This follows from the fact that the mapping class group acts transitively on the set of non-zero cohomologies with coefficients in $\mathbb{Z}/(2\mathbb{Z})$.

Section 3 implements our strategy in a special situation, where \mathcal{M} contains a horizontally periodic surface with three horizontal cylinders, whose core curves span a Lagrangian in homology.

In Section 4, we show that \mathcal{M} must contain a horizontally periodic surface with at least four cylinders. For this, we improve some technical lemmas in [AN16] and use the results of [NW14, ANW16, AN16].

Section 5 addresses the case in which \mathcal{M} contains a horizontally periodic surface with four cylinders. This case turns out to be the most involved in our analysis due to the various situations that may occur. Our main result in this section is Proposition 5.2. For the proof, we split this case into four subcases following the topological type of the cylinder decomposition (see Lemma 5.1), and each subcase is handled differently. In order to keep the focus on the main ideas of the proofs, we defer some technical lemmas to the appendix.

In Section 6, we address the case in which \mathcal{M} contains a horizontally periodic surface with five cylinders. Employing essentially the strategy of collapsing, we come to the conclusion that if $\mathcal{M} \subset \mathcal{H}(2, 1^2)$, then $\mathcal{M} = \tilde{\mathcal{Q}}(2, 1, -1^3)$, and if $\mathcal{M} \subset \mathcal{H}(1^4)$, then either $\mathcal{M} = \tilde{\mathcal{Q}}(2^2, -1^4)$, or \mathcal{M} contains a horizontally periodic surface with six cylinders (see Propositions 6.2, 6.6, 6.11). This allows us to conclude the first part of Theorem 1.3.

Finally, in Section 7 we consider the case in which \mathcal{M} contains a horizontally periodic surface with six cylinders. Necessarily $\mathcal{M} \subset \mathcal{H}(1^4)$. By some elementary combinatorial arguments, we see that in this case there are only four possible cylinder diagrams (see Proposition 7.1). Each cylinder diagram will be handled independently to show that either $\mathcal{M} = \tilde{\mathcal{Q}}(2^2, -1^4)$ or $\mathcal{M} = \tilde{\mathcal{H}}(1, 1)$. This allows us to complete the proof of Theorem 1.3.

Acknowledgements. The authors warmly thank Alex Wright for helpful discussions and for suggesting the formulation of Theorem A. They are also grateful to the Centre International de Rencontres Mathématiques in Marseille for its hospitality and to Vincent Delcroix for providing the list of cylinder diagrams that inspired this work.

2. Preliminaries

We give a brief summary of the essential definitions and important results needed for this paper. Since this paper is very much a sequel to [AN16], all of the notation is consistent between the two papers, and we encourage the reader to refer to [AN16, Sect. 2] for more detailed definitions and background.

Strata and Their Structure: A *translation surface* $M = (X, \omega)$ is a pair of a Riemann surface of genus $g \geq 2$ carrying a non-zero Abelian differential ω . The set $\mathcal{H}(\kappa)$ is the moduli space of translations surface

where κ specifies the orders of the zeros of the differential. Strata admit an action by $\mathrm{GL}_2(\mathbb{R})$ given by multiplying the real and imaginary foliations of ω by elements of the group. There is a natural local system of coordinates on $\mathcal{H}(\kappa)$ given by integrating ω over a basis of $H_1(X, \Sigma, \mathbb{Z})$, where $\Sigma \subset X$ is the set of zeros of ω . These are called *period coordinates*.

Orbit Closures and Their Structure: It was proven in [EMM15], that the $\mathrm{GL}_2(\mathbb{R})$ orbit closure of a translation surface is an (immersed) affine manifold \mathcal{M} (after passing to a suitable finite cover) and that locally \mathcal{M} is a linear subspace of $H^1(X, \Sigma, \mathbb{C})$ in period coordinates. The *field of (affine) definition*, denoted by $\mathbf{k}(\mathcal{M})$, is the smallest subfield of \mathbb{R} containing the coefficients of the linear equations defining \mathcal{M} . It is shown in [Wri14] that this field is of degree at most g over \mathbb{Q} , where g is the genus of a surface in \mathcal{M} .

The *rank of an affine manifold* \mathcal{M} is half the dimension of \mathcal{M} after applying the projection $H^1(X, \Sigma) \rightarrow H^1(X)$. We denote this invariant by $\mathrm{rk}(\mathcal{M})$.

Theorem 2.1 ([Wri14]). *We have*

$$\mathrm{rk}(\mathcal{M}) \deg_{\mathbb{Q}} \mathbf{k}(\mathcal{M}) \leq g.$$

In particular, if \mathcal{M} is a rank two affine submanifold in \mathcal{H}_3 , then $\mathbf{k}(\mathcal{M}) = \mathbb{Q}$.

Remark 2.2. If $\mathbf{k}(\mathcal{M}) = \mathbb{Q}$, then the subset of square-tiled surfaces is dense in \mathcal{M} .

Flat Structure: A *cylinder* on a translation surface is a maximal set of closed trajectories on M that are pairwise homotopic and do not pass through singularities. A *saddle connection* is a flat trajectory that emanates from a zero and terminates at a not necessarily distinct zero. A cylinder is *simple* if each of its boundaries consist of exactly one saddle connection, and it is *semi-simple* if at least one of its boundaries consists of exactly one saddle connection.

Cylinder Decompositions: We say that a translation surface M is *periodic in a direction* $\theta \in \mathbb{RP}^1$, if every geodesic in this direction is either periodic, or a saddle connection. Equivalently, M decomposes into a union of open cylinders and saddle connections in this direction. Therefore, we also say that M admits a cylinder decomposition in direction θ . It follows from a result of Smillie-Weiss [SW04] that every $\mathrm{GL}_2^+(\mathbb{R})$ -orbit closure contains a horizontally periodic surface.

Cylinder Deformations: If two parallel cylinders on M remain parallel on all translation surfaces in a local neighborhood of $M \in \mathcal{M}$, then we say that they are \mathcal{M} -parallel. A cylinder is called *free* if it does not share this property with any other cylinder on M . The relation of being \mathcal{M} -parallel is an equivalence relation.

Let $\mathcal{C} = \{C_1, \dots, C_k\}$ be a family of horizontal cylinders on a surface $M \in \mathcal{M}$. For any $t, s \in \mathbb{R}$, let $a_s = \begin{pmatrix} 1 & 0 \\ 0 & e^s \end{pmatrix}$, and $u_t := \begin{pmatrix} 1 & t \\ 0 & 1 \end{pmatrix}$. We denote by $a_s^{\mathcal{C}}(M)$ (resp. $u_t^{\mathcal{C}}(M)$) the surface obtained by applying a_s (resp. u_t) to every cylinder in \mathcal{C} , while the rest of M remains unchanged. Applying $a_s^{\mathcal{C}}$ is called *stretching*, and applying $u_t^{\mathcal{C}}$ is called *shearing* the cylinders in \mathcal{C} .

Theorem 2.3 ([Wri15], Thm. 5.1). *Let \mathcal{M} be an affine manifold. If \mathcal{C} is an equivalence class of \mathcal{M} -parallel horizontal cylinders on $M \in \mathcal{M}$, then for all $s, t \in \mathbb{R}$, $a_s^{\mathcal{C}}(u_t^{\mathcal{C}}(M)) \in \mathcal{M}$.*

Twist and Preserving Space: Let M be a horizontally periodic translation surface in an affine manifold \mathcal{M} . The *cylinder preserving space* $\text{Pres}(M, \mathcal{M})$ is the largest subspace of the real tangent space to \mathcal{M} at M whose elements evaluate to zero on all core curves of the horizontal cylinders of M . The *twist space* $\text{Twist}(M, \mathcal{M}) \subseteq \text{Pres}(M, \mathcal{M})$ consists of all elements that evaluate to zero on all horizontal saddle connections of M . The following definition is motivated by the lemma below. In the case of rank one affine manifolds it aligns with the definition of \mathcal{M} -stably periodic from [LNW17]. See [LNW17, Rmk. 2.8].

Definition 2.4. Given a horizontally periodic translation surface $M \in \mathcal{M}$, we say M is *\mathcal{M} -cylindrically stable* if $\text{Twist}(M, \mathcal{M}) = \text{Pres}(M, \mathcal{M})$.

Lemma 2.5 ([Wri15], Lem. 8.6). *Let M be a horizontally periodic translation surface in an affine manifold \mathcal{M} . If M is not \mathcal{M} -cylindrically stable, then there exists a horizontally periodic translation surface in \mathcal{M} with more horizontal cylinders than M .*

Cylinder Proportions: Let \mathcal{C} be an equivalence class of \mathcal{M} -parallel cylinders on a translation surface $M \in \mathcal{M}$. Let $X \subset M$ be any cylinder in another direction on M . The *cylinder proportion* of \mathcal{C} in \mathcal{C} is given by

$$P(X, \mathcal{C}) = \frac{\text{Area}(X \cap (\cup_{C \in \mathcal{C}} C))}{\text{Area}(X)}.$$

Proposition 2.6 (Cylinder Proportion Lemma [NW14]). *Let X and Y be \mathcal{M} -parallel cylinders on a translation surface $M \in \mathcal{M}$. Let \mathcal{C} be an equivalence class of \mathcal{M} -parallel cylinders on M . Then $P(X, \mathcal{C}) = P(Y, \mathcal{C})$.*

Cylinder collapsing: We recall that by “collapsing” a cylinder we mean deforming the translation surface by decreasing the height of the cylinder to zero while keeping the rest of the surface unchanged. For a more precise description of this operation, we refer to [AN16, Sect. 2.4]. We first notice

Lemma 2.7 ([Aul15], Lem. 5.4). *Let C be a simple cylinder on a translation surface M . If the zeros (of the holomorphic 1-form) contained in the boundary of C are simple, then they must be distinct.*

The following proposition can be proven without too much effort using the results from [AN16], and in particular, Proposition 2.16 contained therein. However, it is much quicker to use the more general and developed machinery of [MW17]. Since all degenerations in this paper will occur over a compact subset of the moduli space of Riemann surfaces of fixed genus, the results will *not* rely on the multicomponent EMM conjecture.

Proposition 2.8. *Let \mathcal{M} be an affine manifold, and let $M \in \mathcal{M}$. Suppose that M has a free simple cylinder C with two distinct zeros on its boundary components. Let M' be the surface obtained by collapsing C so that the two zeros collide, and let $\mathcal{H}(\kappa')$ where $|\kappa'| = |\kappa| - 1$ be the stratum of M' . Then M' is contained in an affine submanifold $\mathcal{M}' \subset \mathcal{H}(\kappa')$ such that $\text{rk}(\mathcal{M}') = \text{rk}(\mathcal{M})$ and $\dim \mathcal{M}' = \dim \mathcal{M} - 1$.*

Moreover, let U be a neighborhood of M in \mathcal{M} such that for any surface in U , C persists and remains simple. Let $\varphi : U \rightarrow \mathcal{H}(\kappa')$ be the map consisting of collapsing C such that the two zeros in its boundary are identified. Then $\varphi(U)$ is a neighborhood of M' in \mathcal{M}' .

Proof. Let σ be the saddle connection in C that is reduced to a point in M' , and $V = \mathbb{C} \cdot \sigma \subset H_1(X, \Sigma, \mathbb{C})$. By [MW17, Thm. 2.7], the tangent space $T_{M'}(\mathcal{M}')$ is isomorphic to $T_M(\mathcal{M}) \cap \text{Ann}(V)$, where $\text{Ann}(V) = \{\xi \in H^1(X, \Sigma, \mathbb{C}) \mid \xi(\sigma) = 0\}$. By assumption, there is a single saddle connection that vanishes at the boundary, so $\text{Ann}(V)$ has codimension one in $T_M(\mathcal{M})$. It follows that $\dim \mathcal{M}' = \dim \mathcal{M} - 1$. The claim about the equality of the ranks follows from [AN16, Prop. 2.16].

For the final claim, it is enough to remark that in some appropriate period coordinates of $\mathcal{H}(\kappa)$ and $\mathcal{H}(\kappa')$, φ is just the projection from $T_M(\mathcal{M})$ onto $T_M(\mathcal{M}) \cap \text{Ann}(V)$. q.e.d.

Similar cylinders: Let C_1 and C_2 be two simple cylinders in M . Recall that C_i , $i = 1, 2$, is the quotient of an infinite horizontal strip $\tilde{C}_i := \mathbb{R} \times [0, h_i]$ by a \mathbb{Z} -action generated by $(x, y) \mapsto (x + \ell_i, y)$, where h_i and ℓ_i are respectively the height and the circumference of C_i . Note that the lines $\mathbb{R} \times \{0\}$ and $\mathbb{R} \times \{h_i\}$ are mapped to the boundary components of C_i . We can always assume that $(0, 0)$ is mapped to the zero in a boundary component of C_i . The inverse image of the zero in the other component is given by $(a_i, h_i) + \mathbb{Z}(\ell_i, 0)$.

We will call a parallelogram in \tilde{C}_i whose set of vertices is $\{(0, 0), (\ell_i, 0), (a_i + m\ell_i, h_i), (a_i + (m + 1)\ell_i, h_i)\}$, $m \in \mathbb{Z}$, a *normalized fundamental domain* of C_i . We will say that C_1 and C_2 are *similar* or *proportional*,

if there exist two normalized fundamental domains P_1, P_2 of C_1, C_2 respectively such that P_2 is the image of P_1 by a homothety $z \mapsto \lambda z$, with $\lambda > 0$. In particular, if $\lambda = 1$, then C_1 and C_2 are said to be *isometric*. This agrees with the definition of isometric in [ANW16, AN16].

Since C_1 and C_2 are simple, they persist and remain simple on every surface in a sufficiently small neighborhood of M in its stratum. The cylinders C_1 and C_2 are said to be \mathcal{M} -similar, if they are \mathcal{M} -parallel and remain similar on every surface in a neighborhood of $M \in \mathcal{M}$. Note that in this case, there exists a constant λ and normalized fundamental domains such that for any surface M' in a neighborhood of M in \mathcal{M} , we have $P_1^{M'} = \lambda P_2^{M'}$, where $P_i^{M'}$ is a normalized fundamental domain of the cylinder corresponding to C_i in M' . By a slight abuse of notation, we will write $C_1 = \lambda C_2$.

Proposition 2.9. *Assume that $\{C_1, C_2\}$ is an equivalence class of \mathcal{M} -similar simple cylinders on M . Assume that the boundary of C_1 (resp. C_2) contains two distinct zeros, and the pairs of zeros contained in ∂C_1 and ∂C_2 are not the same. Let M' be the surface obtained by twisting and collapsing C_1, C_2 simultaneously such that the zeros in the boundary of C_1 (resp. C_2) collide. Then M' is contained in an affine submanifold \mathcal{M}' of a stratum $\mathcal{H}(\kappa')$, where $|\kappa'| = |\kappa| - 2$, such that $\dim \mathcal{M}' = \dim \mathcal{M} - 1$, and $\text{rk}(\mathcal{M}') = \text{rk}(\mathcal{M})$.*

Moreover, let U be a neighborhood of $M \in \mathcal{M}$ such that for any surface in U , C_1 and C_2 persist and remain simple. Let $\varphi : U \rightarrow \mathcal{H}(\kappa')$ be the map consisting of collapsing C_1 and C_2 such that the two zeros in the boundary of each cylinder are identified. Then $\varphi(U)$ is a neighborhood of M' in \mathcal{M}' .

Proof. For $i = 1, 2$, let σ_i be the unique saddle connection in C_i that is collapsed to a point under the degeneration in the assumption of the proposition, and $V := \mathbb{C} \cdot \sigma_1 \oplus \mathbb{C} \cdot \sigma_2 \subset H_1(X, \Sigma, \mathbb{C})$. By [MW17], we have $T_{M'}(\mathcal{M}') \simeq T_M(\mathcal{M}) \cap \text{Ann}(V)$. By definition,

$$T_M(\mathcal{M}) \cap \text{Ann}(V) = \{\xi \in T_M(\mathcal{M}) \mid \xi(\sigma_1) = \xi(\sigma_2) = 0\}.$$

But by the similarity assumption, there exists a constant $\lambda \in \mathbb{R}_{>0}$ such that for every $\xi \in T_M(\mathcal{M})$, $\xi(\sigma_1) = \lambda \xi(\sigma_2)$. Thus $T_M(\mathcal{M}) \cap \text{Ann}(V) = \{\xi \in T_M(\mathcal{M}) \mid \xi(\sigma_1) = 0\}$. It follows that $\dim T_{M'}(\mathcal{M}') = \dim T_M(\mathcal{M}) - 1$. The final claim follows as in Proposition 2.8. q.e.d.

The following proposition shows that under some assumptions, an involution on the surface obtained from a cylinder collapsing does extend to an involution on the original surface with the same number of fixed points.

Proposition 2.10. *Let M be a translation surface and $\mathcal{C} = \{C_1, \dots, C_k\}$ a family of pairwise \mathcal{M} -similar simple cylinders on M*

in the horizontal direction. We assume that in each C_i there exists a vertical saddle connection δ_i joining the singularities in its boundary, and the graph $G := \bigcup_{i=1}^k \delta_i$ contains no loops (that is G is a disjoint union of topological trees).

Collapse the cylinders in \mathcal{C} simultaneously so that the saddle connections δ_i are all reduced to points, and let M' be the resulting surface. Let Π be the union of distinguished saddle connections resulting from the degeneration of \mathcal{C} on M' . If M' admits an involution whose derivative is $-\text{id}$ that preserves Π , then this involution of M' extends to an involution of M which has the same number of fixed points.

In particular, if M' is contained in the Prym locus or in the hyperelliptic locus of \mathcal{H}_3 , then so is M .

Proof. We first notice that M' is a surface of the same genus as M . To see this, remark that the collapsing of a simple cylinder with distinct zeros (singularities) in its boundary does not change the topology of the surface. Using the assumption that G contains no loops, by induction, we derive that M' has the same genus as M .

Let τ' be the involution of M' . Consider the case $k = 1$, that is \mathcal{C} consists of a single simple cylinder C . In this case Π is a saddle connection σ joining a zero x'_0 of M' to itself where x'_0 is the collision of two zeros in M .

By assumption τ' preserves σ , hence σ contains two fixed points of τ' , one of which is x'_0 the other one is the midpoint of σ . By construction, $M' \setminus \sigma$ is identified with $M \setminus \overline{C}$. Since τ' maps $M' \setminus \sigma$ to itself, we can consider τ' as an involution of $M \setminus \overline{C}$. Note that every simple cylinder admits an involution that exchanges its boundary components and fixes two points in its interior. Therefore, the involution τ' extends to an involution τ of M which fixes the cylinder C . Clearly, τ' and τ have the same number of fixed points.

For the general case, let σ_i denote the degeneration of C_i on M' . Since Π is preserved by τ' , each σ_i is either invariant or permuted with another σ_j . Let $I \subset \{1, \dots, k\}$ be the subset of indices defined by the condition: $i \in I$ if and only if σ_i is invariant by τ' .

Let \tilde{M}' be the surface obtained by reinserting the family of cylinders $\{C_i, |i \in I\}$ to M' . By the argument of the previous case, we conclude that τ' extends to an involution $\tilde{\tau}'$ of \tilde{M}' with the same number of fixed points. By construction, the family $\{\sigma_i, |i \in I^c\}$ persists on \tilde{M}' , and any saddle connection in this family is exchanged with another one by $\tilde{\tau}'$. Since $\tilde{\tau}'$ is an isometry for the flat metric, if σ_i and σ_j are exchanged, then they have the same length. By the assumption of similarity, this means that C_i and C_j are isometric. Thus $\tilde{\tau}'$ extends to an involution τ of M that exchanges C_i and C_j . Clearly, C_i and C_j do not contain any fixed point of τ in their interior. Thus τ and $\tilde{\tau}'$ have the same number of fixed points as do τ and τ' . q.e.d.

Remark 2.11. If M is a genus three Riemann surface, an involution of M is hyperelliptic if and only if it has 8 fixed points.

Topological type of cylinder decompositions: Let M be horizontally periodic, and let \mathcal{C} be the family of all horizontal cylinders of M . By *topological type* of the cylinder decomposition of M , we will mean the topological surface underlying the stable holomorphic 1-form that is the limit $a_t^{\mathcal{C}}(M)$ as $t \rightarrow +\infty$. Equivalently, this is also the surface one obtains after “pinching” all of the core curves of the horizontal cylinders. Note that all of the topological types of cylinder decompositions with three or four cylinders of surfaces in genus three are given in [AN16, Lem. 3.1] and [AN16, Lem. 6.1]. The topological types of the 5-cylinder diagrams are given in Lemma 6.1.

Proposition 2.12. *Let \mathcal{M} be one of the following loci*

$$\{\tilde{\mathcal{Q}}(3, -1^3), \tilde{\mathcal{Q}}(1^2, -1^2), \tilde{\mathcal{Q}}(4, -1^4), \tilde{\mathcal{H}}_{(2,2)}^{\text{odd}}(2), \tilde{\mathcal{Q}}(2, 1, -1^3)\}.$$

- (a) *If $\mathcal{M} = \tilde{\mathcal{Q}}(3, -1^3)$, then there exists a surface admitting a cylinder decomposition with three cylinders of topological type given by Case 3.I).*
- (b1) *If $\mathcal{M} \in \{\mathcal{Q}(1^2, -1^2) \simeq \tilde{\mathcal{H}}_{(2,2)}^{\text{hyp}}(2)\}$, then there exists a surface admitting a cylinder decomposition with four cylinders of topological type given by Case 4.I).*
- (b2) *If $\mathcal{M} \in \{\tilde{\mathcal{H}}_{(2,2)}^{\text{odd}}(2), \tilde{\mathcal{Q}}(4, -1^4)\}$, then there exists a surface admitting a cylinder decomposition with four cylinders of topological type given by Case 4.II).*
- (c) *If $\mathcal{M} = \tilde{\mathcal{Q}}(2, 1, -1^3)$, then there exists a surface admitting a cylinder decomposition with five cylinders of topological type given by Case 5.I).*

Proof. Claims (a), (b1), and (b2) follow from [ANW16, Fig. 7.1], [AN16, Fig. 18], and [AN16, Fig. 21], respectively. For Claim (c), see Figure 14. q.e.d.

We now show

Lemma 2.13. *Let M be a surface in a rank k affine manifold \mathcal{M} such that M contains a free simple cylinder C with distinct zeros on its boundary. Let M' be the surface obtained from M by collapsing C so that the two zeros in its boundary collide. Then M' is contained in an affine manifold \mathcal{M}' in the same genus such that $\text{rank}(\mathcal{M}') = \text{rank}(\mathcal{M}) = k$, and $\dim \mathcal{M}' = \dim \mathcal{M} - 1$. Moreover, if \mathcal{M}' contains a dense subset S such that every surface in S admits a cylinder decomposition of the same topological type, then \mathcal{M} also contains a surface admitting a cylinder decomposition of this topological type.*

Proof. The first claims concerning the rank and dimension follow from [MW17, Thm. 2.7] or [AN16, Prop. 2.16].

Next, we claim that there is an open neighborhood W of $M' \in \mathcal{M}'$ such that every surface in W is obtained from a surface in \mathcal{M} by collapsing a free simple cylinder. To see this we observe that the tangent space $T_{M'}(\mathcal{M}')$ is isomorphic to $\text{Ann}(V) \cap T_M(\mathcal{M})$ by [MW17], where V is the vanishing space, which in this case is generated by the saddle connection $\sigma \subset C$ that collapses to a point. Since each deformation of M that fixes C corresponds to a deformation of M' and vice versa, we see that W has positive measure in \mathcal{M}' .

Let $M'_1 \in S \cap W$. Let c_1 be the saddle connection on M'_1 that is the degeneration of a simple cylinder in a surface $M_1 \in \mathcal{M}$. Observe c_1 is a saddle connection from a zero to itself. By assumption, M'_1 admits a cylinder decomposition of the given topological type in some direction θ . We split the remainder of the argument into two cases.

First, assume that c_1 does *not* lie in direction θ . Cut M'_1 along the saddle connection c_1 , and insert a simple cylinder C . Since every saddle connection between the two zeros in the boundaries of C differs by a Dehn twist, it suffices to choose a shortest and denote it by σ . The foliation of M'_1 in direction θ naturally extends into a neighborhood of the boundary of C . If necessary, twist C so that σ lies in direction θ . This can be accomplished because the directions of σ and c_1 are transverse. We claim that this surface, which we call $M_1 \in \mathcal{M}$ has the same topological type as M'_1 . First we observe that M_1 is periodic in direction θ by construction. Indeed, this construction added a line segment of length equal to that of σ to every leaf of the foliation passing through c_1 . Secondly, if we consider the homotopy classes of the core curves of the cylinders in direction θ , then these are preserved on M . This follows from the observation that there is no leaf of the foliation in direction θ that passes through one zero on the boundary of σ without passing through the zero on the other boundary of σ .²

Second, assume that c_1 does lie in direction θ . In this case, we once again cut M'_1 along c_1 , glue in a simple cylinder C , twist C if necessary so that it does not admit a vertical saddle connection, and collapse the cylinder. The resulting surface will have the same topological type as M'_1 for the same reason as above. q.e.d.

Definition 2.14. Let \mathfrak{c} be a cylinder diagram. We say that an affine manifold \mathcal{M} admits a cylinder diagram \mathfrak{c} if there exists a periodic translation surface $M \in \mathcal{M}$ such that M has cylinder diagram \mathfrak{c} .

²We remark that the intersection of the homology class of any closed leaf of the foliation in direction θ on M_1 with the relative homology class represented by σ is zero. This is a defining property of the construction we used to add a simple cylinder to M'_1 .

Proposition 2.15. *If an affine manifold \mathcal{M} admits a cylinder diagram \mathfrak{c} , then there exists a dense subset $S \subset \mathcal{M}$ of periodic translation surfaces admitting \mathfrak{c} .*

Proof. Let $M' \in \mathcal{M}$ admit cylinder diagram \mathfrak{c} , and without loss of generality, assume that M' admits \mathfrak{c} in the horizontal direction. Let P denote the subgroup of upper triangular matrices in $\mathrm{SL}_2(\mathbb{R})$. By [EMM15, Thm. 2.1], $\overline{P \cdot M'} = \overline{\mathrm{SL}_2(\mathbb{R}) \cdot M'}$. Observe that every translation surface in $P \cdot M'$ is horizontally periodic admitting cylinder diagram \mathfrak{c} . Hence, it suffices to produce $M \in \mathcal{M}$ such that M admits cylinder diagram \mathfrak{c} and $\overline{\mathrm{SL}_2(\mathbb{R}) \cdot M} = \mathcal{M}$.

To produce such an M , consider $T_{M'}^{\mathbb{R}}(\mathcal{M})$. All deformations in this space preserve all horizontal saddle connections, whence they preserve \mathfrak{c} . Since there are at most countably many affine manifolds in \mathcal{M} , there exists a real tangent vector $v \in T_{M'}^{\mathbb{R}}(\mathcal{M})$ such that $\overline{\mathrm{SL}_2(\mathbb{R}) \cdot (M' + v)} = \mathcal{M}$. Let $M = M' + v$. q.e.d.

2.1. Unramified double covers.

Lemma 2.16. *Let $M = (X, \omega)$ be a translation surface in genus three. The surface M admits a Prym involution and a hyperelliptic involution if and only if there exists a translation surface $M' = (X', \omega')$ in genus two, and an unramified double cover $p : X \rightarrow X'$ such that $p^*\omega' = \omega$.*

Proof. First assume X admits a Prym involution τ and a hyperelliptic involution ι . Since ι commutes with all automorphisms of X , $\rho = \tau \circ \iota$ is also an involution of X which satisfies $\rho^*\omega = \omega$. Let $X' := X/\langle \rho \rangle$ be the quotient of X by ρ .

For any involution f of X , let

$$\begin{aligned} \Omega^+(X, f) &:= \{\xi \in \Omega(X) \mid f^*\xi = \xi\}, \text{ and} \\ \Omega^-(X, f) &:= \{\xi \in \Omega(X) \mid f^*\xi = -\xi\}. \end{aligned}$$

By definition, $\dim \Omega(X') = \dim \Omega^+(X, \rho)$. Since ι acts by $-\mathrm{id}$ on $\Omega(X)$, we have $\dim \Omega^+(X, \rho) = \dim \Omega^-(X, \tau) = 2$. Thus X' is a surface of genus two. The Riemann-Hurwitz formula then implies that the double cover $p : X \rightarrow X'$ is unramified. Since $\omega \in \Omega^+(X, \rho)$, there exists a holomorphic 1-form ω' on X' such that $\omega = p^*\omega'$.

Conversely, if there exists an unramified double cover of translation surface $p : M \rightarrow M'$, then M' must be a surface of genus two, and M admits an automorphism ρ such that $p \circ \rho = p$ and $\rho^2 = \mathrm{id}$. The automorphism ρ is induced by any element of $\pi_1(M')$ that is not contained in $p_*\pi_1(M)$. Since M' is of genus two, it has a hyperelliptic involution which lifts to a hyperelliptic involution ι of M . The composition $\iota \circ \rho$ is then a Prym involution. The details are left to the reader. q.e.d.

The following proposition shows that the locus of unramified double covers of translation surfaces of genus two in $\mathcal{H}(1^4)$ is connected, thus it consists of a single rank two affine submanifold of $\mathcal{H}(1^4)$. Note that this locus is also the intersection $\mathcal{P} \cap \mathcal{L} \cap \mathcal{H}(1^4)$ by Lemma 2.16.

Proposition 2.17. *The locus $\tilde{\mathcal{H}}(1, 1)$ of pairs $(X, \omega) \in \mathcal{H}(1^4)$ such that there exist a pair $(X', \omega') \in \mathcal{H}(1, 1)$ and an unramified double cover $\pi : X \rightarrow X'$ satisfying $\pi^*\omega' = \omega$ is connected.*

Proof. Let \mathfrak{M}_g be the moduli space of Riemann surfaces of genus g . Let $\tilde{\mathfrak{M}}_2 \subset \mathfrak{M}_3$ denote the locus of Riemann surfaces of genus three that are unramified double covers of some surface of genus two. We first show that $\tilde{\mathfrak{M}}_2$ is connected.

Let us fix a topological closed surface of genus two S . Assume that we have a topological covering of degree two $p : \hat{S} \rightarrow S$. We then have $\chi(\hat{S}) = 2\chi(S) = -4$, hence \hat{S} must be a surface of genus three.

By definition $p_*(\pi_1\hat{S})$ is a subgroup of index two of π_1S . Thus there exists a group homomorphism $\varepsilon : \pi_1S \rightarrow \mathbb{Z}/(2\mathbb{Z})$ such that $p_*(\pi_1\hat{S}) = \ker \varepsilon$. Since $\mathbb{Z}/(2\mathbb{Z})$ is abelian, ε can be written as $h \circ \mathbf{p}$, where $\mathbf{p} : \pi_1S \rightarrow H_1(S, \mathbb{Z})$ is the natural projection, and $h : H_1(S, \mathbb{Z}) \rightarrow \mathbb{Z}/(2\mathbb{Z})$ is a homomorphism of abelian groups. Note that we can consider h as an element of $H^1(S, \mathbb{Z}/(2\mathbb{Z})) \setminus \{0\}$.

Conversely, given an element $h \in H^1(S, \mathbb{Z}/(2\mathbb{Z})) \setminus \{0\}$, then $\Gamma = \mathbf{p}^{-1}(\ker h)$ is a (normal) subgroup of index two in π_1S . Thus $p : \tilde{S}/\Gamma \rightarrow S$ is a (topological) double cover, where \tilde{S} is the universal cover of S . In particular, \tilde{S}/Γ is a closed surface of genus three. From classical results on covering spaces, we know that if $p_1 : \hat{S}_1 \rightarrow S$ and $p_2 : \hat{S}_2 \rightarrow S$ are two double covers which correspond to the same element of $H^1(S, \mathbb{Z}/(2\mathbb{Z}))$, then p_1 and p_2 are isomorphic, that is there exists a homeomorphism $f : \hat{S}_1 \rightarrow \hat{S}_2$ such that $p_1 = p_2 \circ f$. Thus we have shown the following

Claim 1: There is a bijection between the set of topological double covers of S up to isomorphism and the set $H^1(S, \mathbb{Z}/(2\mathbb{Z})) \setminus \{0\}$.

Let us now fix a topological double covering $p : \hat{S} \rightarrow S$ and denote by h the element of $H^1(S, \mathbb{Z}/(2\mathbb{Z}))$ associated to p . Let $r_0 : X_0 \rightarrow X'_0$ and $r_1 : X_1 \rightarrow X'_1$ be two unramified double covers of (compact) Riemann surfaces, where X_i is of genus three and X'_i is of genus two. Our goal is to show that there is a path in $\tilde{\mathfrak{M}}_2$ from X_0 to X_1 . We first show

Claim 2: There are two homeomorphisms $\phi_i : S \rightarrow X'_i$, $i = 0, 1$, such that the topological covering $\phi_i^{-1} \circ r_i$ is isomorphic to p .

Proof. It is enough to show the existence of ϕ_0 . Let $f_0 : S \rightarrow X'_0$ be any homeomorphism and consider the double cover $p_0 = f_0^{-1} \circ r_0 : X_0 \rightarrow$

S . Let h_0 be the element of $H^1(S, \mathbb{Z}/(2\mathbb{Z}))$ associated to p_0 . Since the action of the Mapping Class Group $MCG(S)$ on $H^1(S, \mathbb{Z}/(2\mathbb{Z})) \setminus \{0\}$ is transitive (see [FM12, Chap. 6]), there exists a homeomorphism $\varphi_0 : S \rightarrow S$ such that $(\varphi_0^{-1})^*h_0 = h$. Setting $\phi_0 := f_0 \circ \varphi_0 : S \rightarrow X'_0$, from Claim 1, we see that the covers p and $\phi_0^{-1} \circ r_0$ are isomorphic. q.e.d.

Since p and $\phi_i^{-1} \circ r_i$ are isomorphic, there exists a homeomorphism $\tilde{\phi}_i : \hat{S} \rightarrow X_i$ that satisfies $p = (\phi_i^{-1} \circ r_i) \circ \tilde{\phi}_i$, or equivalently $\phi_i \circ p = r_i \circ \tilde{\phi}_i$. Remark that if we equip S with the conformal structure of X'_i via ϕ_i , we then get an induced conformal structure on \hat{S} and $\tilde{\phi}_i : \hat{S} \rightarrow X_i$ becomes an isomorphism of Riemann surfaces.

$$\begin{array}{ccc} \hat{S} & \overset{\tilde{\phi}_i}{\dashrightarrow} & X_i \\ p \downarrow & & \downarrow r_i \\ S & \xrightarrow{\phi_i} & X'_i \end{array}$$

We now notice that the pairs (X'_i, ϕ_i) , $i = 0, 1$, represent two points in the Teichmüller space \mathcal{T}_2 . Since \mathcal{T}_2 is connected, there exists a path $[X'_t, \phi_t]$, $t \in [0, 1]$ connecting those two points (here X'_t is a Riemann surface of genus two, $\phi_t : S \rightarrow X_t$ is a homeomorphism, and $[X'_t, \phi_t]$ is the equivalence class of (X'_t, ϕ_t)). Since $\phi_t \circ p : \hat{S} \rightarrow X'_t$ is a double cover, the conformal structure of X'_t induces a conformal structure on \hat{S} . Let X_t denote the corresponding Riemann surface. By construction X_t is an unramified double cover of X'_t , which means that $X_t \in \widetilde{\mathfrak{M}}_2$. Thus we have found a path in $\widetilde{\mathfrak{M}}_2$ from X_0 to X_1 , which shows that $\widetilde{\mathfrak{M}}_2$ is connected.

Recall that the stratum $\mathcal{H}(1, 1)$ is a subset of the Abelian differential bundle $\Omega\mathfrak{M}_2$ over \mathfrak{M}_2 . Each fiber of $\Omega\mathfrak{M}_2$ is the space of holomorphic 1-forms on a Riemann surface X of genus two, thus can be identified with \mathbb{C}^2 . The intersection of this fiber with $\mathcal{H}(1, 1)$ is the set of holomorphic 1-forms on X with two simple zeros. Remark that the double zero of a holomorphic 1-form on X must be a Weierstrass point, and every genus two Riemann surface has exactly 6 Weierstrass points. Therefore, $\mathcal{H}(1, 1) \cap \Omega(X)$ can be identified with \mathbb{C}^2 minus 6 complex lines. Hence we can realize $\mathcal{H}(1, 1)$ as a bundle over \mathfrak{M}_2 whose fibers are \mathbb{C}^2 minus 6 complex lines.

$$\begin{array}{ccc} \tilde{\mathcal{H}}(1, 1) & \dashrightarrow & \mathcal{H}(1, 1) \\ \downarrow & & \downarrow \\ \tilde{\mathfrak{M}}_2 & \longrightarrow & \mathfrak{M}_2 \end{array}$$

By definition, $\tilde{\mathcal{H}}(1, 1)$ is the pullback of this bundle to $\tilde{\mathcal{M}}_2$. Since $\tilde{\mathcal{M}}_2$ is connected and the fibers of this bundle are connected, we conclude that $\tilde{\mathcal{H}}(1, 1)$ is connected. q.e.d.

3. A special case of cylinder collapsing

Throughout this section, \mathcal{M} will be a rank two affine submanifold of either $\mathcal{H}(2, 1^2)$ or $\mathcal{H}(1^4)$. Using the tools provided in Section 2 and the classification of rank two affine submanifolds in the strata $\mathcal{H}(\kappa) \subset \mathcal{H}_3$ where $|\kappa| \leq 2$, we will show that in a special case one can get immediately the desired conclusions about \mathcal{M} . Recall that a cylinder decomposition in Case 3.I) means that the cylinder decomposition consists of three cylinders such that the three core curves span a Lagrangian in homology.

Proposition 3.1. *Assume that \mathcal{M} contains a horizontally periodic surface M satisfying Case 3.I) such that two of the cylinders are simple and there are at least two equivalence classes of cylinders. Then*

- (a) *If $\mathcal{M} \subset \mathcal{H}(2, 1^2)$, then $\mathcal{M} = \tilde{\mathcal{Q}}(2, 1, -1^3)$.*
- (b) *If $\mathcal{M} \subset \mathcal{H}(1^4)$, then $\mathcal{M} = \tilde{\mathcal{H}}(1, 1)$ or $\mathcal{M} = \tilde{\mathcal{Q}}(2^2, -1^4)$.*

Remark 3.2. It can be shown that if M is a horizontally periodic satisfying Case 3.I) in a rank two affine manifold, then the horizontal cylinders must fall into two equivalence classes.

Proof. Let C_1, C_2, C_3 denote the horizontal cylinders of M , where C_1, C_2 are simple. By [AN16, Lem. 2.11], we know that none of C_1, C_2 is \mathcal{M} -parallel to C_3 . By [AN16, Lem. 2.15], C_1, C_2, C_3 cannot all be free. Therefore, we can conclude that C_1, C_2 are \mathcal{M} -parallel, and C_3 is free. The arguments in [AN16, Lem. 5.3] allow us to conclude that C_1 and C_2 are actually isometric. Moreover, after twisting C_3 , we can assume that any vertical ray exiting $C_i, i = 1, 2$, from its top border reenters C_i through the bottom border after crossing the core curves of C_3 once.

Let σ_i, σ'_i be respectively the top and bottom borders of C_i , then the condition above means that there is a pair of homologous vertical saddle connections δ_i, δ'_i contained in C_3 joining the left endpoint (resp. right endpoint) of σ_i to the left endpoint (reps. right endpoint) of σ'_i . Let M_i denote the subsurface of M cut out by δ_i, δ'_i that contains C_i . Remark that M_i is a slit torus, and M_1, M_2 are isometric.

Case $\mathcal{M} \subset \mathcal{H}(2, 1^2)$. Let x_0 denote the unique double zero of M , and x_1, x_2 the simple ones.

Claim: *The boundary of $C_i, i = 1, 2$, must contain two distinct zeros.*

Proof. Without loss of generality, let us suppose on the contrary that the boundary of C_1 contains only one zero. By Lemma 2.7, this zero

must be x_0 . A simple computation shows that the total angle at x_0 inside M_1 is 4π . Therefore, the angle at x_0 outside of M_1 is 2π . If we remove M_1 from M and glue δ_1, δ'_1 together such that the points corresponding to x_0 in δ_1 and δ'_1 are identified, we will obtain a surface M'_1 in the stratum $\mathcal{H}(1, 1)$ which admits a cylinder decomposition with two cylinders in the horizontal direction.

Note that x_0 gives rise to a regular point in M'_1 , and C_2 can be considered as a (simple) cylinder in M'_1 . The pair $\{\delta_1, \delta'_1\}$ now corresponds to a vertical simple closed geodesic on M'_1 . Remark that there is a unique diagram for 2-cylinder decompositions of surfaces in $\mathcal{H}(1, 1)$ such that one of the cylinders is simple. We then observe that the condition that the larger cylinder contains vertical simple closed geodesic, and a pair of vertical saddle connections that cut out a slit torus cannot be satisfied. Therefore we get a contradiction. q.e.d.

It is also easy to see that a simple zero cannot occur in the boundaries of both C_1 and C_2 by an angle count. Therefore, we can assume that the boundary of C_1 contains x_0 and x_1 , and the boundary of C_2 contains x_0 and x_2 . As a consequence collapsing simultaneously C_1 and C_2 so that all the zeros collide yields a surface M' in $\mathcal{H}(4)$. From Proposition 2.9, we know that M' is contained in a rank two affine submanifold \mathcal{M}' of $\mathcal{H}(4)$ which satisfies

$$\dim \mathcal{M}' = \dim \mathcal{M} - 1.$$

From the results of [ANW16] and [NW14], we must have $\mathcal{M}' = \tilde{\mathcal{Q}}(3, -1^3)$. By construction, M' is horizontally periodic with a unique horizontal cylinder C . Since $M \in \tilde{\mathcal{Q}}(3, -1^3)$, M' admits a Prym involution τ .

Let $\tilde{\sigma}_1$ (resp. $\tilde{\sigma}_2$) denote the horizontal saddle connection in M' that is the degeneration of C_1 (resp. of C_2). We claim that $\tilde{\sigma}_1$ and $\tilde{\sigma}_2$ are exchanged by τ . If they are not exchanged by τ , then in any neighborhood of M' in $\tilde{\mathcal{Q}}(3, -1^3)$ we can find a surface on which $\tilde{\sigma}_1$ and $\tilde{\sigma}_2$ remain but the corresponding holonomy vectors are not equal. Since such a surface is obtained from a surface in \mathcal{M} by collapsing $\{C_1, C_2\}$, this contradicts the condition that C_1 and C_2 are isometric.

Since τ exchanges $\tilde{\sigma}_1$ and $\tilde{\sigma}_2$, by Proposition 2.10, we see that τ extends to a Prym involution on M . As a consequence, $M \in \mathcal{H}(2, 1, 1) \cap \mathcal{P} = \tilde{\mathcal{Q}}(2, 1, -1^3)$. Since the same is true for all surfaces in \mathcal{M} close to M (see Proposition 2.9), we draw that $\mathcal{M} \subset \tilde{\mathcal{Q}}(2, 1, -1^3)$. Notice that we have

$$\dim \mathcal{M} = \dim \tilde{\mathcal{Q}}(3, -1^3) + 1 = \dim \tilde{\mathcal{Q}}(2, 1, -1^3) = 5.$$

Using the ergodicity of the action of $\text{SL}(2, \mathbb{R})$ on \mathcal{M} , we conclude that $\mathcal{M} = \tilde{\mathcal{Q}}(2, 1, -1^3)$.

Case $\mathcal{M} \subset \mathcal{H}(1^4)$. By Lemma 2.7, we know that the boundary of C_i , $i = 1, 2$, must contain two distinct zeros. By computing the angles at the zeros, it is also easy to check that a simple zero cannot be contained in the boundaries of both C_1 and C_2 . Therefore, we can conclude that the boundaries of C_1 and C_2 contain two different pairs of simple zero. Thus collapsing simultaneously C_1, C_2 so that the zeros in each pair collide, we obtain a surface M' in $\mathcal{H}(2, 2)$. Let $\tilde{\sigma}_1$ and $\tilde{\sigma}_2$ be the horizontal saddle connections in M' that are the degenerations of C_1 and C_2 respectively.

By Proposition 2.9, we know that M' is contained in some rank two affine submanifold \mathcal{M}' of $\mathcal{H}(2, 2)$ such that $\dim \mathcal{M} = \dim \mathcal{M}' + 1$. By the results of [AN16], we must have

$$\mathcal{M}' \in \{\tilde{\mathcal{H}}_{(2,2)}^{\text{hyp}}(2), \tilde{\mathcal{H}}_{(2,2)}^{\text{odd}}(2), \tilde{\mathcal{Q}}(4, -1^4)\}.$$

In all cases, let τ be the Prym involution of M' .

- 1) Assume that $\mathcal{M}' = \tilde{\mathcal{H}}_{(2,2)}^{\text{hyp}}(2)$. In this case, τ fixes each of the zeros of M' , and there is a hyperelliptic involution ι which exchanges the two zeros of M' . By definition, ι has 8 fixed points. Note that two fixed points of ι are contained in the interior of C_3 (which is the unique horizontal cylinder in M').

The hyperelliptic involution ι induces a permutation on the set of horizontal saddle connections of M' . Since ι permutes the zeros of M' , a saddle connection fixed by ι must join one zero to the other one. In particular, each saddle connection fixed by ι contains exactly one fixed point. We now remark that each $\tilde{\sigma}_i$ is a saddle connection joining a zero of M' to itself (this zero is the collision of two simple zeros in M). In particular, $\tilde{\sigma}_i$ is not invariant by ι . Since M' has 6 horizontal saddle connections, this implies that ι has at most 4 fixed points in the union of the horizontal saddle connections. Thus ι has at most 6 fixed points, which is a contradiction, and we can conclude that $\mathcal{M}' \neq \tilde{\mathcal{H}}_{(2,2)}^{\text{hyp}}(2)$.

- 2) Assume now that $\mathcal{M}' = \tilde{\mathcal{H}}_{(2,2)}^{\text{odd}}(2)$. In this case, τ exchanges the zeros of M' , and there is a hyperelliptic involution ι that fixes each of the zeros of M' . It follows that ι has 6 regular fixed points in M' . Recall that two fixed points of ι are contained in the interior of C_3 . Hence, ι has 4 regular fixed points in the union of the horizontal saddle connections. Remark that each fixed point must be contained in a saddle connection which joins a zero of M' to itself. Since there are 6 horizontal saddle connections, and at least two of them have distinct endpoints, it follows that every saddle connection that joins a zero of M' to itself is invariant by ι . In particular, each of $\tilde{\sigma}_1, \tilde{\sigma}_2$ is invariant by ι .

We claim that τ exchanges $\tilde{\sigma}_1$ and $\tilde{\sigma}_2$. This is because otherwise we can deform M' slightly in $\tilde{\mathcal{H}}_{(2,2)}^{\text{odd}}(2)$ such that the holonomy vectors associated to $\tilde{\sigma}_1$ and $\tilde{\sigma}_2$ are not equal, which would contradict the condition that C_1 and C_2 are isometric.

Now, the observations above mean that the set $\tilde{\sigma}_1 \cup \tilde{\sigma}_2$ is preserved by both τ and ι . We can now use Proposition 2.10 to conclude that ι and τ extend to two involutions $\hat{\iota}$ and $\hat{\tau}$ of M with the same number of fixed points respectively. In particular, $\hat{\iota}$ must be a (the) hyperelliptic involution, and $\hat{\tau}$ a Prym involution of M . We thus have $M \in \mathcal{H}(1^4) \cap \mathcal{P} \cap \mathcal{L} = \tilde{\mathcal{H}}(1, 1)$. Since the same is true for any surface in \mathcal{M} close enough to M (see Proposition 2.9), we derive that $\mathcal{M} \subseteq \tilde{\mathcal{H}}(1, 1)$. Since we have

$$\dim \mathcal{M} = \dim \tilde{\mathcal{H}}_{(2,2)}^{\text{odd}}(2) + 1 = 5 = \dim \tilde{\mathcal{H}}(1, 1),$$

it follows that $\mathcal{M} = \tilde{\mathcal{H}}(1, 1)$.

- 3) Consider finally the case $\mathcal{M}' = \tilde{\mathcal{Q}}(4, -1^4)$. By the same argument as the previous case, we see that τ must permute $\tilde{\sigma}_1$ and $\tilde{\sigma}_2$. Thus, τ gives rise to a Prym involution of M by Proposition 2.10, which means that $M \in \tilde{\mathcal{Q}}(2^2, -1^4)$. Since the same is true for any surface in \mathcal{M} close enough to M , we derive that $\mathcal{M} \subseteq \tilde{\mathcal{Q}}(2^2, -1^4)$. Finally, since we have

$$\dim \mathcal{M} = \dim \tilde{\mathcal{Q}}(4, -1^4) + 1 = 6 = \dim \tilde{\mathcal{Q}}(2^2, -1^4),$$

it follows that $\mathcal{M} = \tilde{\mathcal{Q}}(2^2, -1^4)$. q.e.d.

4. Getting four cylinders

The goal of this section is to prove that every rank two affine manifold in the strata $\mathcal{H}(2, 1, 1)$ and $\mathcal{H}(1^4)$ contain a translation surface with at least four cylinders. However, this cannot be done all at once. Due to our argument below, we can only prove this result for $\mathcal{H}(2, 1, 1)$. Once the classification of rank two affine manifolds in $\mathcal{H}(2, 1, 1)$ is established, the desired result for the principal stratum will follow automatically. We state the main result of the section here.

Proposition 4.1. *Let \mathcal{M} be a rank two affine manifold in genus three.*

- (1) *If $\mathcal{M} \subset \mathcal{H}(2, 1, 1)$, then \mathcal{M} contains a horizontally periodic surface with at least four horizontal cylinders.*
- (2) *Assume that $\tilde{\mathcal{Q}}(2, 1, -1^3)$ is the only rank two affine manifold in $\mathcal{H}(2, 1, 1)$. If $\mathcal{M} \subset \mathcal{H}(1^4)$, \mathcal{M} contains a horizontally periodic surface with at least four horizontal cylinders.*

By [AN16, Lem. 3.2], we know that \mathcal{M} always contains a horizontally periodic surface with at least three cylinders. The following lemma is a generalization of [AN16, Lem. 3.3].

Lemma 4.2. *Let \mathcal{M} be a rank two affine manifold in genus three in a stratum with $k \geq 2$ zeros. Assume that every rank two affine manifold in genus three with at most $k - 1$ zeros admits an involution with four fixed points whose derivative is $-\text{id}$.³ If \mathcal{M} contains a horizontally periodic translation surface with two cylinders, one of which is simple, then \mathcal{M} contains a horizontally periodic surface with at least three cylinders, one of which is simple and not free.*

Proof. Let $M \in \mathcal{M}$ be a horizontally periodic surface with two horizontal cylinders C_1 and C_2 , where C_1 is simple. If C_1 and C_2 are \mathcal{M} -parallel, then we are done by [AN16, Lem. 2.14]. Thus let us suppose that C_1 is free. We claim that given any two zeros in M , there always exists a path between them consisting of horizontal saddle connections. This is because if we cut M along a core curve of C_1 and a core curve of C_2 , then the resulting surface is connected. Otherwise, C_1 and C_2 are homologous, thus they cannot be free.

Note that each boundary component of C_1 contains a single zero of M . Let x_1 be a zero of highest order in M . Observe that there must exist a horizontal saddle connection σ connecting x_1 to another zero x_2 . Since σ is not one of the boundary components of C_1 , it must be contained in both sides of C_2 , thus we have a simple cylinder D contained in C_2 whose boundary contains x_1 and x_2 . We consider the following cases:

- x_1 is of order ≥ 2 : We claim that D is not free. Indeed, if this is the case, then we can collapse D to get a surface M' in a stratum with $k - 1$ zeros, one of the zeros of M' is of order at least 3. Thus M' belongs to $\mathcal{H}(3, 1)$ or $\mathcal{H}(4)$. Since there is no rank two affine submanifold in $\mathcal{H}(3, 1)$, we only need to consider the case $M' \in \mathcal{H}(4)$. In this case we must have $M' \in \tilde{\mathcal{Q}}(3, -1^3)$. In particular, M' has an involution τ with four fixed points whose derivative is $-\text{id}$. Note that the unique zero of M must be a fixed point of τ . By construction, M' has two horizontal cylinders, one of which is simple, the other one is not. Thus, they are both fixed by τ . But a cylinder fixed by τ must contain two fixed points of τ in its interior. Therefore, τ must have at least 5 fixed points, which is a contradiction.

Since \mathcal{M} is defined over \mathbb{Q} , we can assume that D is vertical and M is a square-tiled surface. Since D is not free, it is \mathcal{M} -parallel to another vertical cylinder D' , which must be entirely contained in the closure of C_2 . In particular, D and D' do not fill M . Thus there exists at least another vertical cylinder, which means that we have at least 3 vertical cylinders, one of which is simple and not free.

³For example, this is true of all surfaces in the Prym locus.

- x_1 is a simple zero, i.e. $M \in \mathcal{H}(1^4)$: if D is free, then we can collapse it to get a surface $M' \in \mathcal{H}(2, 1^2)$. Since the involution of M' must fix the double zero, by the same argument as above we get a contradiction. Thus D is not free, and we also get the desired conclusion. q.e.d.

Recall that in [AN16, Lem. 4.1], we have divided 3-cylinder diagrams in genus three into three Cases 3.I), 3.II), 3.III). The following is a slight generalization of [AN16, Prop. 5.5].

Proposition 4.3. *Let \mathcal{M} be a rank two affine manifold in genus three with at least two zeros. If $M \in \mathcal{M}$ is a horizontally periodic translation surface satisfying Case 3.I) and two of the horizontal cylinders are simple, then there is a horizontally periodic surface in \mathcal{M} with at least four cylinders.*

Proof. By [AN16, Lem. 5.3], the two simple cylinders in M are \mathcal{M} -parallel and isometric. Furthermore, they can be twisted so that there is a vertical trajectory passing exactly once through each. This yields either Case (A) or (B) in Figure 2. Next, consider the vertical direction after perturbing to a nearby square-tiled surface, we see that each of the simple cylinders must be contained in (the closure of) a vertical cylinder. Therefore, there must exist at least three vertical cylinders.

If there are four or more cylinders, then we are done. Otherwise, there is a vertical cylinder D which is contained in the closure C_3 . Since no cylinder parallel to D is entirely contained in \overline{C}_3 , D is free by [NW14, Prop. 3.3(b)]. After rotating the surface M by $\pi/2$ and redrawing, we get the horizontally periodic surfaces in Figure 3. In both cases, we twist the horizontal cylinder D so that saddle connection c lies where it does in both figures. By applying [AN16, Lem. 2.14] or [SW04, Cor. 6] to the vertical direction yields a translation surface with four or more parallel cylinders. q.e.d.

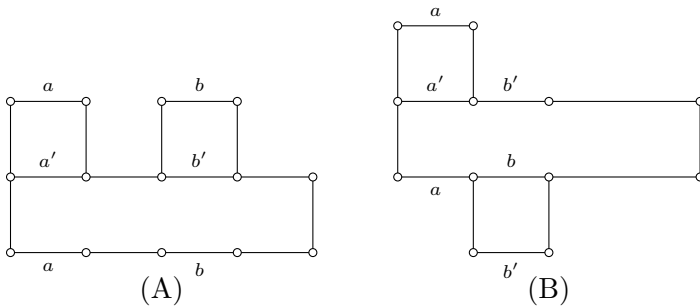

Figure 2. 3-cylinder diagrams with two simple cylinders.

Let M be a horizontally periodic surface in $\mathcal{H}(2, 1^2) \cup \mathcal{H}(1^4)$. Let G be the graph which is the union of all horizontal saddle connections

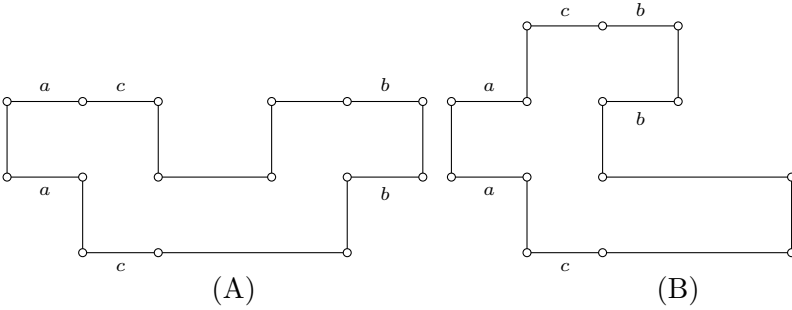

Figure 3. 3-cylinder diagrams with at least four vertical cylinders.

in M . This graph is called the *separatrix diagram* in the literature and has a *ribbon structure* (see [KZ03, Sec. 4]). If $M \in \mathcal{H}(2, 1, 1)$, then G has 3 vertices and 7 edges. If $M \in \mathcal{H}(1^4)$, then G has 4 vertices and 8 edges. Note that the valency of a simple zero is 4 and of a double zero is 6. Since each edge of G is a horizontal saddle connection in M , we can equip it with the orientation from the left to the right.

Let U be a neighborhood of G in M consisting of the points whose distance to G is at most ϵ , with $\epsilon > 0$ small enough. Each component of ∂U is a core curve of a horizontal cylinder, and also homotopic to a cycle of edges of G . We say that two boundary components are *adjacent* if the corresponding cycles have a common edge.

We color a component of ∂U red if its orientation (which is induced by the orientation of U) agrees with the orientation of the corresponding cycle in G , otherwise we color it blue. A red boundary component corresponds to the upper side of a cylinder, while a blue one corresponds to the lower side of a cylinder. Clearly, we have a pairing between the set of red boundary components and the set of blue ones, two boundary components are paired if they belong to the same cylinder. Note that two adjacent boundary components must have different colors because a saddle connection cannot be contained in the tops (resp. bottoms) of two different cylinders.

Proposition 4.4. *Let $M \in \mathcal{H}(2, 1^2) \cup \mathcal{H}(1^4)$ be a horizontally periodic translation surface satisfying Case 3.I). Then at least one of the following occurs*

- (a) *One of the cylinders is semi-simple,*
- (b) *There is a horizontal saddle connection contained in both the top and bottom of the same cylinder.*

Proof. Consider the separatrix diagram G and its neighborhood U described above. The hypothesis implies that G is connected and U is homeomorphic to a sphere with six open discs removed. As a consequence, G is a planar graph.

A loop in G is an edge that joins a vertex to itself. If there is a component of ∂U that is homotopic to a loop in G , then one of the cylinders is semi-simple. Since G is planar, and using the hypothesis on the number of edges and vertices of G , one can easily check that if there are some loops in G , then there must exist a loop which bounds a disc. Hence, in this case we have a semi-simple cylinder.

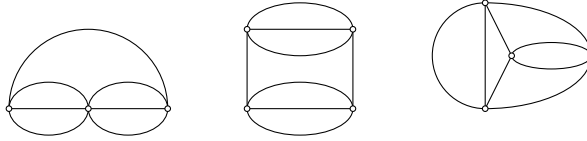

Figure 4. Admissible configurations for the graph of saddle connections with no loops in Case 3.I).

Assume from now on that there are no loops in G . There are three admissible configurations for G , which are shown in Figure 4, one for $\mathcal{H}(2, 1^2)$ and two for $\mathcal{H}(1^4)$. Observe that in all cases, the outer boundary component of U is adjacent to three other boundary components. Therefore, the outer component must be paired with one of the adjacent ones. This implies immediately that there is an edge of G that is contained in both the top and the bottom sides of the corresponding cylinder. The proposition is then proved. q.e.d.

Proof of Proposition 4.1.

Proof. By [AN16, Lem. 3.2], there exists a horizontally periodic surface $M \in \mathcal{M}$ with at least three cylinders. By [AN16, Lem. 4.1], M satisfies one of three possible cases.

- (a) If M satisfies Case 3.II), then by the assumption and [AN16, Lem. 4.3], M is \mathcal{M} -cylindrically unstable. Thus there exists $M' \in \mathcal{M}$ that is horizontally periodic with at least four horizontal cylinders.
- (b) If M satisfies Case 3.III), then denote the homologous cylinders by C_1, C_2 , and the remaining one by C_3 . If we cut M along a core curve in each of C_1, C_2 , then glue the boundary components of the new surface after exchanging the pairings, we will obtain two translation surfaces of genus two, both of which are horizontally periodic. One of the new surfaces has two horizontal cylinders one of which is C_3 . We denote this surface M^1 , and the other one M^2 . Note that since M^1 is a genus two translation surface, C_3 is either simple or contains a horizontal saddle connection in both of its sides.

We have several possibilities. Assume that C_3 contains a simple cylinder C . If the boundary of C contains only simple zeros, then the simple zeros are distinct by Lemma 2.7. It is easy to check that there is no cylinder parallel to C that is entirely contained

in C_3 . Hence, C is free and can be collapsed. Note that in this case M degenerates to a surface M' in $\mathcal{H}(2, 2)$ or $\mathcal{H}(2, 1^2)$. By Proposition 2.8, M is contained in a rank two affine submanifold \mathcal{M}' in $\mathcal{H}(2, 2)$ or in $\mathcal{H}(2, 1^2)$ such that $\dim \mathcal{M}' = \dim \mathcal{M} - 1$. By the results of [AN16] and the hypothesis of the proposition, \mathcal{M}' is one of the following loci

$$\{\tilde{\mathcal{H}}_{(2,2)}^{\text{hyp}}(2), \tilde{\mathcal{H}}_{(2,2)}^{\text{odd}}(2), \tilde{\mathcal{Q}}(4, -1^4), \tilde{\mathcal{Q}}(2, 1, -1^3)\}.$$

By Proposition 2.12, there exists $M' \in \mathcal{M}'$ admitting a cylinder decomposition with four or more cylinders. We conclude by Proposition 2.15 and Lemma 2.13.

If the boundary of C_3 contains a double zero, then the two zeros in its boundary are the same, and we have a cylinder diagram similar to [AN16, Lem. 4.8]. But in this case it is easy to check that the proof of [AN16, Prop. 4.8] goes through without any challenge even though the top of C_1 and the bottom of C_2 contain four saddle connections instead of three.

Finally, if C_3 is itself a simple cylinder, we apply [AN16, Lem. 4.7] to reduce to the previous cases.

- (c) If M satisfies Case 3.I), by Proposition 4.4, we know that either one of the horizontal cylinders is semi-simple or contains a simple cylinder. If the latter occurs, since we can always suppose that the simple cylinder is vertical and M is a square-tiled surface, it follows that \mathcal{M} contains a vertically periodic surface with one simple vertical cylinder. Using Lemma 4.2, we derive that \mathcal{M} contains a horizontally periodic surface with at least 3 cylinders one of which is simple. If the cylinder diagram of this surface satisfies Case 3.II or Case 3.III, then we conclude as above. Thus, we are left to consider the case M is horizontally periodic satisfying Case 3.I, and one of the horizontal cylinders is semi-simple.

We only need to consider the case M is \mathcal{M} -cylindrically stable. Since the horizontal cylinders of M cannot be all free (see [AN16, Lem. 2.15]), they must fall into two equivalence classes. Let us denote these cylinders by C_1, C_2, C_3 , where C_1 and C_2 are \mathcal{M} -parallel, while C_3 is free. Let us first consider the case one of the horizontal cylinders is simple. By Proposition 4.3, we can assume that only one of C_1, C_2, C_3 is simple. If one of C_1 and C_2 is simple, then the other one is not, and we conclude by [AN16, Prop. 5.6]. If C_3 is simple, then we conclude by [AN16, Prop. 5.9], and Proposition 4.3. Finally, in the case where none of C_1, C_2, C_3 is simple, and one of them is strictly semi-simple, we conclude by [AN16, Prop. 5.14] and Proposition 4.3. q.e.d.

5. Four cylinders

We recall [AN16, Lem 6.1] that enumerates all topological types of 4-cylinder decompositions in genus three.

Lemma 5.1. [AN16] *If a translation surface M in genus three decomposes into four cylinders, then pinching the core curves of those cylinders degenerates the surface to one of four possible surfaces:*

- 4.I) Two spheres joined by four pairs of simple poles.
- 4.II) Two spheres joined by two pairs of simple poles such that each sphere has a pair of simple poles.
- 4.III) Two spheres joined by three pairs of simple poles such that one sphere carries an additional pair of simple poles.
- 4.IV) Two spheres and a torus such that the spheres have three simple poles and the torus has two simple poles.

In what follows we will individually consider each of those topological types of 4-cylinder decomposition. The final result is the following.

Proposition 5.2. *Let \mathcal{M} be a rank two affine submanifold of either $\mathcal{H}(2, 1^2)$ or $\mathcal{H}(1^4)$. Assume that \mathcal{M} contains a horizontally periodic surface with 4 horizontal cylinders.*

- (a) *If $\mathcal{M} \subset \mathcal{H}(2, 1^2)$, then either \mathcal{M} contains a horizontally periodic surface with 5 horizontal cylinders or $\mathcal{M} = \tilde{\mathcal{Q}}(2, 1, -1^3)$.*
- (b) *If $\mathcal{H} \subset \mathcal{H}(1^2)$, and assume that $\tilde{\mathcal{Q}}(2, 1, -1^3)$ is the unique rank two affine submanifold in $\mathcal{H}(2, 1^2)$, then either \mathcal{M} contains a horizontally periodic surface with at least 5 horizontal cylinders or $\mathcal{M} \in \{\mathcal{H}(1, 1), \tilde{\mathcal{Q}}(2^2, -1^4)\}$.*

Proof. This proposition is the consequence of Corollary 5.4 and the Propositions 5.7, 5.10, 5.11, 5.13, 5.15, 5.20, and 5.30. q.e.d.

The proofs of the results mentioned above use several technical lemmas, that are essential but somewhat tedious as the ideas involved already appeared in the previous work [NW14, ANW16, AN16]. For this reason, we defer some of their proofs to the appendix in order to keep the focus on the novelties.

5.1. Case 4.IV). In this case the core curves of the cylinders cut the surface into two three-holed spheres, and a two-holed torus.

The following lemma follows from the proof of [Aul15, Lem. 5.6]. The two possible conclusions correspond to the possibility that M is \mathcal{M} -cylindrically stable, which was assumed in the proof of [Aul15, Lem. 5.6], or to the possibility that M is \mathcal{M} -cylindrically unstable, in which case we can produce more cylinders.

Lemma 5.3. *Let \mathcal{M} be a rank two affine manifold in genus three. If $M \in \mathcal{M}$ is a horizontally periodic translation surface satisfying Case*

4.IV), then either M has a free simple cylinder with distinct zeros at each end, or there exists $M' \in \mathcal{M}$ admitting a cylinder decomposition with at least five cylinders.

Corollary 5.4. *Let \mathcal{M} be a rank two affine manifold in $\mathcal{H}(2, 1^2)$ or $\mathcal{H}(1^4)$. If $\mathcal{M} \subset \mathcal{H}(1^4)$, then we add the additional assumption that the only rank two affine submanifold of $\mathcal{H}(2, 1^2)$ is $\tilde{Q}(2, 1, -1^3)$. If $M \in \mathcal{M}$ is a horizontally periodic translation surface satisfying Case 4.IV), then either \mathcal{M} contains a horizontally periodic surface in Case 4.I) or 4.II), or there exists $M' \in \mathcal{M}$ horizontally periodic with at least five cylinders.*

Proof. By Lemma 5.3, we only need to consider the case M has a free simple cylinder C with different zeros on its boundary. Collapsing C results in a translation surface M' which is contained in a rank two affine submanifold \mathcal{M}' of a lower stratum of genus three. Since there is no rank two affine submanifold in $\mathcal{H}(3, 1)$, we derive that either $\mathcal{M}' \subset \mathcal{H}(2, 2)$ or $\mathcal{M}' \subset \mathcal{H}(2, 1^2)$. From Proposition 2.12 we know that either \mathcal{M}' contains a surface admitting a cylinder decomposition satisfying either Case 4.I), 4.II), or 5.I). We can then conclude by Proposition 2.15 and Lemma 2.13. q.e.d.

5.2. Case 4.III). In this case, the core curves of the cylinders cut M into a three-holed sphere and a five-holed sphere, the former contains a simple zero, while the latter contains the other zeros of M . Let us denote by x_0 the simple zero contained in the three-holed sphere. This zero is contained in the boundary of three cylinders, denoted by C_1, C_2, C_3 . We number them so that $\ell(C_3) = \ell(C_1) + \ell(C_2)$. The remaining cylinder is denoted by C_4 . Let c_i be a core curve of C_i .

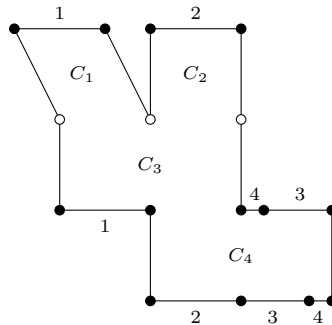

Figure 5. Case 4.III) in $\mathcal{H}(2, 1^2)$: cylinder labels, the white vertex is x_0 .

Remark that all of the horizontal saddle connections starting from x_0 end at x_0 . The other horizontal saddle connections form a connected planar graph G with 2 or 3 vertices, such that a neighborhood of G is homeomorphic to a five-holed sphere. We start by

Lemma 5.5. *Let \mathcal{M} be a rank two affine manifold in a stratum in genus three with at least three zeros. If \mathcal{M} contains a horizontally periodic surface M with four cylinders satisfying Case 4.III) such that M is \mathcal{M} -cylindrically stable, then the equivalence classes are $\{C_1, C_2, C_3\}$ and $\{C_4\}$.*

Proof. Since \mathcal{M} is of rank two, the horizontal cylinders belong to at least two equivalence classes. Either C_4 is free, or it is not. If C_4 is free, then the relation $c_1 + c_2 = c_3$ implies that either all three cylinders C_1, C_2, C_3 are free, or they belong to the same equivalence class. In the former case, all four cylinders are free and we have a contradiction with the rank two assumption. Hence, if C_4 is free, then we are done.

If C_4 is not free, then it is \mathcal{M} -parallel to another cylinder say C_1 . Since there are at least two equivalence classes, no other cylinder can be \mathcal{M} -parallel to C_4 . Hence, C_2 and C_3 must be free. Let ξ_i denote the vector in $H^1(M, \Sigma, \mathbb{R})$ which is tangent to the path defined by the shearing of C_i . Since C_2 and C_3 are free, it follows that ξ_2 and ξ_3 are contained in $T_M^{\mathbb{R}}\mathcal{M}$. The condition that C_1 and C_4 are \mathcal{M} -parallel implies that $\xi_1 + \xi_4 \in T_M^{\mathbb{R}}\mathcal{M}$.

Note that one can identify $H^1(M, \Sigma, \mathbb{R})$ and $H^1(M, \mathbb{R})$ with $H_1(M \setminus \Sigma, \mathbb{R})$ and $H_1(M, \mathbb{R})$ respectively by using Poincaré duality (see [MW17, §4.1] for details). Moreover, in this setting, the natural projection $p : H^1(M, \Sigma, \mathbb{R}) \rightarrow H^1(M, \mathbb{R})$ can be identified with the projection $p' : H_1(M \setminus \Sigma, \mathbb{R}) \rightarrow H_1(M, \mathbb{R})$. Using this identification, up to a non-zero constant ξ_i is equal to $[c_i] \in H_1(M \setminus \Sigma, \mathbb{R})$, and $p(\xi_i)$ is equal to $p'([c_i]) = [c_i] \in H_1(M, \mathbb{R})$ (see [Wri15, Rem. 2.5]). As a consequence, we see that there exist $a, b \in \mathbb{R}_{>0}$ such that the vectors $a[c_1] + b[c_4], [c_2], [c_3]$ all belong to $p(T_M^{\mathbb{R}}\mathcal{M})$. But those vectors span a three dimensional isotropic subspace of $H_1(M, \mathbb{R})$ which contradicts the fact that $p(T_M^{\mathbb{R}}\mathcal{M})$ is symplectic and the assumption that $\dim p(T_M^{\mathbb{R}}\mathcal{M}) = 4$. Therefore, C_4 must be free and the lemma follows. q.e.d.

Lemma 5.6. *Let \mathcal{M} be a rank two affine submanifold in a stratum with at least three zeros. Assume that $M \in \mathcal{M}$ admits a cylinder decomposition satisfying Case 4.III) in the horizontal direction. Then either C_4 is semi-simple or C_4 contains a free simple cylinder with two distinct zeros in its boundary.*

Proof. See Appendix A. q.e.d.

We can now show

Proposition 5.7. *Let \mathcal{M} be a rank two affine manifold in a stratum in genus three with at least three zeros. If $\mathcal{M} \subset \mathcal{H}(1^4)$, then we add the assumption that $\mathcal{Q}(2, 1, -1^3)$ is the unique rank two affine submanifold in $\mathcal{H}(2, 1^2)$. If $M \in \mathcal{M}$ is horizontally periodic with four cylinders and M is \mathcal{M} -cylindrically stable, then M does not satisfy Case 4.III).*

Proof. By Lemma 5.6 we have to consider two cases

- C_4 contains a free simple cylinder D with two distinct zeros in its boundary. Collapsing D , we get a surface M' in a rank two affine manifold \mathcal{M}' which is contained in either $\mathcal{H}(3, 1)$ or $\mathcal{H}(2, 1, 1)$. The former case is ruled out since $\mathcal{H}(3, 1)$ contains no rank two affine submanifolds. For the latter case, by the hypothesis, we must have $M' = \tilde{Q}(2, 1, -1^3)$, hence M' admits a Prym involution τ . This involution must send x_0 to another simple zero x_1 , hence the saddle connections containing x_0 are mapped to those that contain x_1 . Since all the horizontal saddle connections starting from x_0 join x_0 to itself, the same is true for the saddle connections starting from x_1 . But by assumption, x_1 is contained in the same component as the double zero after the pinching of the core curves of C_i , $i = 1, \dots, 4$, which means that there is a horizontal saddle connection joining x_1 and the double zero. Thus we have a contradiction which rules out this case.
- C_4 is semi-simple. By Lemma A.1, we know that C_4 is not simple. Using the fact that each saddle connection in the boundary of C_4 must be contained in the boundary of another cylinder, by an angle count, it is not difficult to check that the boundary of C_4 contains at least two distinct zeros. We can twist then collapse C_4 such that there is a unique (vertical) saddle connection joining two different zeros that is shrunk to a point. The resulting surface must be contained in a rank two affine submanifold of $\mathcal{H}(3, 1)$ or $\mathcal{H}(2, 1, 1)$. The remainder of the proof follows from the same arguments as the previous case. q.e.d.

5.3. Case 4.II). Let M be a horizontally periodic surface in \mathcal{M} with four cylinders satisfying Case 4.II). We will denote the homologous cylinders by C_1 and C_2 , and the remaining cylinders by C_3 and C_4 . In particular, C_1 and C_2 are \mathcal{M} -parallel.

Note that if we cut M along a core curve of C_1 and a core curve of C_2 and exchange the gluings, we will obtain two genus two translation surfaces containing C_3 and C_4 , respectively. Thus we have

Lemma 5.8. *Either C_3 (resp. C_4) is a simple cylinder, or there exist some saddle connections that are contained in both top and bottom of C_3 (resp. C_4).*

For $i = 3, 4$, let k_i be the number of saddle connections that are contained in both top and bottom of C_i . Lemma 5.8 implies that $k_i = 0$ if and only if C_i is a simple cylinder. We will need the following

Lemma 5.9. *Let M be a horizontally periodic translation surface satisfying Case 4.II) in a rank two affine manifold $\mathcal{M} \subset \mathcal{H}(2, 1^2) \cup \mathcal{H}(1^4)$. Assume that M is \mathcal{M} -cylindrically stable. Then C_3 and C_4 are \mathcal{M} -parallel, and $k_3 = k_4$.*

Proof. See Appendix B.

q.e.d.

Proposition 5.10. *Let $M \in \mathcal{H}(2, 1^2)$ be a horizontally periodic translation surface in a rank two affine manifold \mathcal{M} . If M is \mathcal{M} -cylindrically stable, then M does not satisfy Case 4.II).*

Proof. Set $k = k_3 = k_4$. If $k = 0$, then both C_3 and C_4 are simple. Twist and perform an extended cylinder collapse (see [AN16, Lem. 4.7]) to get a new translation surface such that both C_3 and C_4 contain simple cylinders. Therefore, we can assume that $k > 0$, which means that \overline{C}_3 and \overline{C}_4 contain some simple cylinders.

Without loss of generality, let C_3 be the cylinder with the double zero in its boundary, and C_4 be the cylinder with two simple zeros in its boundary. Since C_3 can be realized as a cylinder in some surface in $\mathcal{H}(2)$, there is a unique saddle connection, denoted by σ_3 , which is contained in both top and bottom of C_3 . By Lemma 5.9, there is also a unique saddle connection σ_4 which is contained in both top and bottom of C_4 .

Let D be a simple cylinder in \overline{C}_3 consisting of closed geodesics crossing σ_3 once. Let D' be the cylinder in the equivalence class of D which is contained in \overline{C}_4 . Note that D' is also a simple cylinder (but its core curves may cross σ_4 more than once), and its complement in C_4 is a rectangle that we will denote by R_4 .

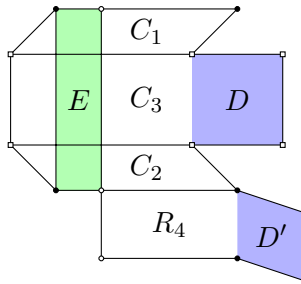

Figure 6. Case 4.II) for surfaces in $\mathcal{H}(2, 1, 1)$: C_3, C_4 not simple.

Using the arguments of [AN16, Lem. 6.17], we see that $\{C_1, C_2\}$ can be twisted simultaneously so that there is a vertical cylinder E contained in the union of C_1, C_2, C_3 crossing each of those cylinders once (see Figure 6). Since C_4 is \mathcal{M} -parallel to C_3 , it must be crossed by some cylinders in the equivalence class of E . Consider a cylinder E' in the equivalence class of E which crosses C_4 . Let γ be a core curve of E' . Let $n_i, i = 1, 2, 3$, be the number of intersections of γ with a core curve of C_i , and n_4 be its number of intersections with the top side of R_4 (n_4 is not necessarily the number of intersections of γ with a core curve of C_4). Observe that we must have $n_1 = \dots = n_4$. Let h_i denote the height

of C_i , $i = 1, 2, 3$, and h_4 the height of the rectangle R_4 (which is also the circumference of D'). Denote by \mathcal{C} the equivalence class $\{C_3, C_4\}$. By the Cylinder Proportion Lemma, we must have $P(E, \mathcal{C}) = P(E', \mathcal{C})$ which implies

$$\frac{h_3}{h_1 + h_2 + h_3} = \frac{h_3 + h_4}{h_1 + h_2 + h_3 + h_4} \Leftrightarrow \frac{h_1 + h_2}{h_3} = \frac{h_1 + h_2}{h_3 + h_4}.$$

The last equation holds if and only if $h_4 = 0$ or $h_1 + h_2 = 0$. In either case, we have a contradiction which proves the proposition. q.e.d.

Proposition 5.11. *Let \mathcal{M} be a rank two affine submanifold of $\mathcal{H}(1^4)$. If \mathcal{M} contains a horizontally periodic surface M satisfying Case 4.II) such that M is \mathcal{M} -cylindrically stable, then either $\mathcal{M} = \tilde{\mathcal{H}}(1, 1)$ or $\mathcal{M} = \tilde{\mathcal{Q}}(2^2, -1^4)$.*

Proof. Recall that by Lemma 5.9, we have $k_3 = k_4 = k$. If C_3 is a simple cylinder, then C_4 is as well. In this case, by twisting so that neither cylinder contains a vertical saddle connection and performing an extended cylinder collapse as in [AN16, Pf. of Lem. 4.7], we get a translation surface satisfying Case 4.II) such that in the new surface each of C_3 and C_4 contains at least one cylinder. Therefore we only need to consider the case $k \in \{1, 2\}$.

Case $k = 1$. Let σ_3 (resp. σ_4) be the unique saddle connection contained in both top and bottom of C_3 (resp. C_4). There is simple cylinder D in $\overline{C_3}$ that contains σ_3 . We can assume that M is square-tiled, and D is vertical. Let D' be the cylinder in $\overline{C_4}$ which is \mathcal{M} -parallel to D . Note that D' is also a simple cylinder.

We claim that D and D' are similar (proportional). If D and D' are not similar, then we can twist them so that one of them contains a horizontal saddle connection but the other does not. As D and D' are collapsed simultaneously only one saddle connection is contracted to a point. Thus the resulting surface belongs to an rank two affine submanifold in $\mathcal{H}(2, 1^2)$. By construction, this new surface also admits a cylinder decomposition in Case 4.II) in the horizontal direction, but this contradicts Proposition 5.10.

Since D and D' are proportional, we can collapse them simultaneously so that two saddle connections joining distinct simple zeros are contracted. The resulting surface, denoted by M' , belongs to a rank two affine submanifold \mathcal{M}' in $\mathcal{H}(2, 2)$. By Proposition 2.9, we have $\dim \mathcal{M} = \dim \mathcal{M}' + 1$. Note that the cylinders in M' that correspond to C_3 and C_4 are simple. By a slight abuse of notation, we will also denote them by C_3 and C_4 , respectively.

Since M' admits a cylinder decomposition in Case 4.II), we derive that $M' \in \mathcal{H}^{\text{odd}}(2, 2)$ (see [AN16, Sec. 6.3]). By the main result of [AN16], we know that $\mathcal{M}' \in \{\tilde{\mathcal{H}}^{\text{odd}}_{(2,2)}(2), \tilde{\mathcal{Q}}(4, -1^4)\}$. In both cases C_3 and C_4 are

exchanged by the Prym involution of M' , thus they are isometric. It follows that the circumferences of D and D' are equal. Since D and D' are similar, they are actually isometric. By Proposition 2.10, the Prym involution of M' extends to an involution of M , that also exchanges C_3 and C_4 . In particular, we see that $M \in \tilde{\mathcal{Q}}(2^2, -1^4)$. Since the same arguments apply to the surfaces in a neighborhood of M in \mathcal{M} , we conclude that $\mathcal{M} \subset \tilde{\mathcal{Q}}(2^2, -1^4)$.

If $\mathcal{M}' = \tilde{\mathcal{Q}}(4, -1^4)$, then $\dim \mathcal{M} = \dim \tilde{\mathcal{Q}}(4, -1^4) + 1 = 6$ by Proposition 2.9. Since $\dim \tilde{\mathcal{Q}}(2^2, -1^4) = 6$, we conclude that $\mathcal{M} = \tilde{\mathcal{Q}}(2^2, -1^4)$.

If $\mathcal{M}' = \tilde{\mathcal{H}}_{(2,2)}^{\text{odd}}(2)$, then M' has a hyperelliptic involution ι that fixes C_3 and C_4 . It is easy to check that ι preserves the saddle connection in C_3 (resp. in C_4) which is the degeneration of D (resp. of D') in M' . Thus ι extends to a hyperelliptic involution on M (see Proposition 2.10). Hence, $M \in \tilde{\mathcal{H}}(1, 1)$ by Lemma 2.16 and $\mathcal{M} \subset \tilde{\mathcal{H}}(1, 1)$ by Proposition 2.9. Note that in this case we have $\dim \mathcal{M} = \dim \tilde{\mathcal{H}}_{(2,2)}^{\text{odd}}(2) + 1 = 5 = \dim \tilde{\mathcal{H}}(1, 1)$. Thus \mathcal{M} must be the locus $\tilde{\mathcal{H}}(1, 1)$.

Case $k = 2$. Consider a simple cylinder $D \subset \bar{C}_3$ that crosses the core curves of C_3 once. Let \mathcal{D} denote the equivalence class of D . Since C_4 is \mathcal{M} -parallel to C_3 , it must be crossed by a cylinder $D' \in \mathcal{D}$. Since D is disjoint from C_1 and C_2 , so is D' , which means that D' is contained in \bar{C}_4 .

We can assume that M is square-tiled and D and D' are vertical. Since C_3 can be realized as a cylinder in a two-cylinder decomposition of a surface in the stratum $\mathcal{H}(1, 1)$, \bar{C}_3 contains at most one vertical cylinder. This implies that D is the unique cylinder in \mathcal{D} that crosses C_3 , because any other vertical cylinder that crosses C_3 would also cross C_1 or C_2 while D does not.

We now claim that D' is simple. To see this, we first remark that C_4 can be realized as a cylinder in a surface in $\mathcal{H}(1, 1)$. Thus D' can be viewed as a cylinder in a translation surface of genus two as well. Assume that D' is not simple, then its closure contains a simple cylinder E' . There must exist a cylinder E which is \mathcal{M} -parallel to E' and crosses D (and hence C_3). Since D is simple, E cannot be contained in D . Now, since D is the unique cylinder in \mathcal{D} that crosses C_3 , we have $P(E, \mathcal{D}) < 1$. But by assumption, we have $P(E', \mathcal{D}) = 1$, therefore we get a contradiction to the Cylinder Proportion Lemma 2.6 which proves the claim.

The remainder of the proof follows the same lines as the previous case. q.e.d.

5.4. Case 4.I. In this case the core curves of the cylinders cut the surface into two four-holed spheres. Denote the horizontal cylinders of M by C_1, \dots, C_4 . For $i = 1, \dots, 4$, let h_i and ℓ_i denote respectively the height and the circumference of C_i , and γ_i be a core curve of C_i . By

assumption, the following homological relation holds:

$$\gamma_1 + \varepsilon_2\gamma_2 + \varepsilon_3\gamma_3 + \varepsilon_4\gamma_4 = 0,$$

where $\varepsilon_i = \pm 1$. After possibly relabeling the cylinders and multiplying ε_i by -1 , there are two distinct equations that are possible:

- Case 4.I.a) $\gamma_1 - \gamma_2 - \gamma_3 - \gamma_4 = 0$, or
- Case 4.I.b) $\gamma_1 + \gamma_2 - \gamma_3 - \gamma_4 = 0$.

We will analyze the cylinder diagrams according to the equation they satisfy.

Let G be the embedded graph in M whose vertices are the zeros and edges are the horizontal saddle connections. By assumption, G has two connected components denoted by G_1 and G_2 . Cutting M along $\gamma_1, \dots, \gamma_4$, we obtain two four-holed spheres, which can be considered as regular neighborhoods of G_1 and G_2 . It follows in particular that G_1 and G_2 are planar graphs. Observe also that any closed curve in M cannot intersect $\gamma_1 \cup \dots \cup \gamma_4$ only once. Therefore, none of C_1, \dots, C_4 contains a saddle connection in both its top and bottom.

Using the fact that G_1 and G_2 are planar, one can easily produce the list of admissible configurations for G_1 and G_2 together with the corresponding homological relation satisfied by $\gamma_1, \dots, \gamma_4$ (see Figure 7).

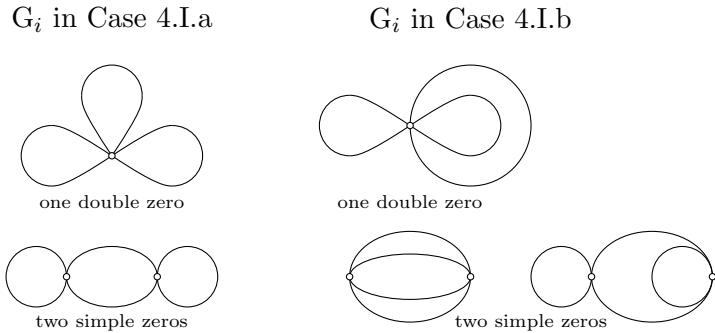

Figure 7. Configurations of G_i , $i = 1, 2$, in Case 4.I.

5.4.1. Case 4.I.a). In this case, we can assume without loss of generality that the top of C_1 is equal to the union of the bottoms of C_2, C_3, C_4 .

Lemma 5.12. *Assume that M is a horizontally periodic surface in \mathcal{M} satisfying Case 4.I.a) such that M is \mathcal{M} -cylindrically stable. Then for $i = 2, 3, 4$, if C_i is semi-simple, then C_i is not \mathcal{M} -parallel to C_1 .*

Proof. Since \mathcal{M} is of rank two, the horizontal cylinders fall into at least two equivalence classes. Let \mathcal{C} denote the equivalence class of C_1 . Observe that $\{C_2, C_3, C_4\}$ cannot be an equivalence class by the homological relation.

By contradiction, assume that C_2 is semi-simple and \mathcal{M} -parallel to C_1 . Since we have at least two equivalence classes of cylinders, neither C_3 nor C_4 is \mathcal{M} -parallel to C_1 , which means that $\mathcal{C} = \{C_1, C_2\}$. Since C_2 is semi-simple, we can assume that the bottom of C_2 consists of one saddle connection σ . Let σ' be a saddle connection in the top of C_2 . Note that σ and σ' are contained in the top and bottom of C_1 respectively. We can twist C_1 and C_2 such that any vertical ray entering C_1 through σ' crosses σ . There exists in this case a transverse cylinder D_1 , not necessarily vertical, contained in $\overline{C_1} \cup \overline{C_2}$ whose core curves cross each of γ_1, γ_2 once. Twisting $\{C_1, C_2\}$ again, we can assume that D_1 is vertical. Let \mathcal{D} denote the equivalence class of D_1 , and assume that $\mathcal{D} = \{D_1, \dots, D_s\}$.

We claim that D_j is contained in $\overline{C_1} \cup \overline{C_2}$ for all $j = 1, \dots, s$. This is a consequence of the Cylinder Proportion Lemma and the fact that $P(D_1, \mathcal{C}) = 1$. It follows that each D_j crosses γ_1 and γ_2 the same number of times n_j . Let h'_j be the height of D_j , and ℓ_i be the circumference of C_i . Applying the Cylinder Proportion Lemma, we have $P(C_1, \mathcal{D}) = P(C_2, \mathcal{D})$, which is equivalent to

$$\frac{n_1 h'_1 + \dots + n_s h'_s}{\ell_1} = \frac{n_1 h'_1 + \dots + n_s h'_s}{\ell_2} \Leftrightarrow \ell_1 = \ell_2.$$

However, this is impossible because $\ell_1 = \ell_2 + \ell_3 + \ell_4$. q.e.d.

Proposition 5.13. *If \mathcal{M} is a rank two affine submanifold of $\mathcal{H}(2, 1^2)$, then \mathcal{M} does not contain an \mathcal{M} -cylindrically stable horizontally periodic surface satisfying Case 4.I.a).*

Proof. Assume to the contrary that M is an \mathcal{M} -cylindrically stable horizontally periodic surface in \mathcal{M} satisfying Case 4.I.a). In $\mathcal{H}(2, 1^2)$, by inspection of the admissible configurations of the graphs G_1, G_2 , we see that each of $\{C_2, C_3, C_4\}$ is semi-simple. Lemma 5.12 establishes the existence of a free semi-simple cylinder in this case. However, M cannot have a free semi-simple cylinder because it could be twisted to contain a single vertical saddle connection between a double zero and a simple one, and hence could be collapsed to a translation surface in $\mathcal{H}(3, 1)$. But this contradicts the non-existence of a rank two affine manifold in that stratum. q.e.d.

The following lemma follows from an inspection of the admissible configurations of the graphs G_1, G_2 .

Lemma 5.14. *In the principal stratum in genus three, there are exactly two cylinder diagrams satisfying Case 4.I.a). They are depicted in Figure 8.*

Proposition 5.15. *Let \mathcal{M} be a rank two affine submanifold of $\mathcal{H}(1^4)$. Assume that $\tilde{\mathcal{Q}}(2, 1, -1^3)$ is the only rank two affine manifold in $\mathcal{H}(2, 1^2)$.*

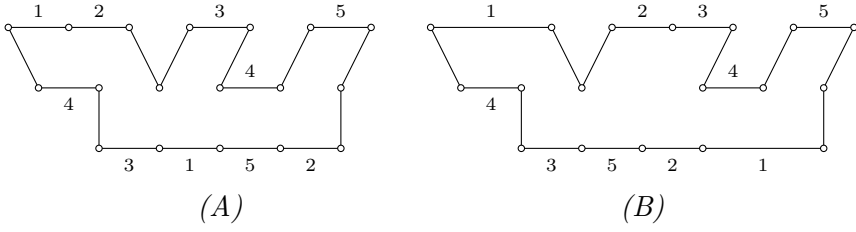

Figure 8. The Two Cylinder Diagrams Satisfying Case 4.I.a) in $\mathcal{H}(1^4)$.

If \mathcal{M} contains an \mathcal{M} -cylindrically stable horizontally periodic surface M satisfying Case 4.I.a), then either $\mathcal{M} = \tilde{\mathcal{H}}(1, 1)$ or $\mathcal{M} = \tilde{\mathcal{Q}}(2^2, -1^4)$.

Proof. By Lemma 5.14, there are two cases to consider.

Case (A): Denote the simple cylinders by C_3 and C_4 . By Lemma 5.12, neither of them is \mathcal{M} -parallel to C_1 . Therefore, either one of them, say C_4 is free, or they are \mathcal{M} -parallel. Suppose to a contradiction that C_4 is free. Collapse it so that two zeros in its boundary collide. The resulting surface M' belongs to a rank two affine submanifold \mathcal{M}' of $\mathcal{H}(2, 1^2)$. By assumption, $\mathcal{M}' = \tilde{\mathcal{Q}}(2, 1, -1^3)$. In particular, M' admits an involution τ with four fixed points whose derivative is $-\text{id}$. Note that M' has three horizontal cylinders. It is easy to see that none of them can be permuted with another one by τ . Thus all three cylinders are invariant by τ , which implies that τ has at least six fixed points in the interior of the cylinders. This contradiction means that C_3 and C_4 must be \mathcal{M} -parallel.

We claim that C_3 and C_4 are \mathcal{M} -similar. Indeed, if they are not, then twist and collapse them such that only one pair of simple zeros in their boundaries collide. The resulting surface M' belongs to a rank two affine submanifold of $\mathcal{H}(2, 1^2)$. By assumption, $M' \in \tilde{\mathcal{Q}}(2, 1, -1^3)$, thus M' has an involution τ with four fixed points. Remark that M' is horizontally periodic with two horizontal cylinders that we keep denoting by C_1 and C_2 . Observe that τ must fix each of C_1 and C_2 , hence τ has at least four fixed points in the interiors of C_1 and C_2 . But the double zero of M' must also be a fixed point of τ . Thus, τ has at least five fixed points, and we have a contradiction which implies that C_3 and C_4 are \mathcal{M} -similar.

Twist and collapse C_3 and C_4 simultaneously such that the pairs of zeros in their boundaries collide, we get a surface M' which is contained in a rank two affine submanifold \mathcal{M}' of $\mathcal{H}(2, 2)$ (by Proposition 2.9). For $i = 3, 4$, let σ_i denote saddle connection which the degeneration of C_i on M' .

By the results of [AN16], M' admits a Prym involution τ with four fixed points. Since M' has two horizontal cylinders which cannot be

exchanged by an involution, τ must fix each of these cylinders. Consequently, τ has four fixed points in the interiors of the cylinders. It follows that the zeros of M' are exchanged by τ , which means that $M' \in \mathcal{H}^{\text{odd}}(2, 2)$, and hence $\mathcal{M}' \in \{\tilde{\mathcal{H}}_{(2,2)}^{\text{odd}}(2), \tilde{\mathcal{Q}}(4, -1^4)\}$.

Observe also that τ must exchange σ_3 and σ_4 , otherwise τ would have more than four fixed points. Thus, τ extends to a Prym involution on M by Proposition 2.10. Therefore, $M \in \tilde{\mathcal{Q}}(2^2, -1^4)$. It follows from Proposition 2.9 that $\tilde{\mathcal{Q}}(2^2, -1^4)$ contains a neighborhood of M in \mathcal{M} , hence $\mathcal{M} \subseteq \tilde{\mathcal{Q}}(2^2, -1^4)$.

If $\mathcal{M}' = \tilde{\mathcal{Q}}(4, -1^4)$, then $\dim \mathcal{M} = \dim \tilde{\mathcal{Q}}(4, -1^4) + 1 = \dim \tilde{\mathcal{Q}}(2^2, -1^4) = 6$. Thus, $\mathcal{M} = \tilde{\mathcal{Q}}(2^2, -1^4)$.

If $\mathcal{M}' = \tilde{\mathcal{H}}_{(2,2)}^{\text{odd}}(2)$, then M' has a hyperelliptic involution ι . One can check that ι fixes each of σ_3 and σ_4 , thus extends to a hyperelliptic involution of M . Therefore $M \in \mathcal{H}(1^4) \cap \mathcal{P} \cap \mathcal{L} = \tilde{\mathcal{H}}(1, 1)$. Since in this case $\dim \mathcal{M} = \dim \tilde{\mathcal{H}}(1, 1) = 5$, we must have $\mathcal{M} = \tilde{\mathcal{H}}(1, 1)$.

Case (B): Let C_4 be the unique simple cylinder. Since in this case all of the cylinders C_2, C_3, C_4 are semi-simple, none of them is \mathcal{M} -parallel to C_1 by Lemma 5.12. Since they cannot belong to the same equivalence class either, at least one of them is free.

If C_2 or C_3 is free, then collapse it to obtain a surface M' in $\mathcal{H}(2, 1^2)$. By [AN16, Prop. 2.16], M' belongs to a rank two affine submanifold \mathcal{M}' of $\mathcal{H}(2, 1^2)$. By assumption, $\mathcal{M} = \tilde{\mathcal{Q}}(2, 1, -1^3)$, which means that M' admits a Prym involution τ with four fixed points. But such an involution must fix all three cylinders, which means that τ has at least six fixed points and we get a contradiction.

It remains to consider the case C_4 is free. Collapsing it, we obtain a surface $M' \in \tilde{\mathcal{Q}}(2, 1, -1^3)$. Note that in this case the Prym involution τ of M' fixes C_1 , and permutes C_2 and C_3 . In particular, τ leaves invariant the saddle connection which is the degeneration of C_4 . By Proposition 2.10, τ extends to an involution of M with four fixed points. Thus we have $\mathcal{M} \subset \tilde{\mathcal{Q}}(2^2, -1^4)$. Since we have $\dim \mathcal{M} = \dim \tilde{\mathcal{Q}}(2, 1, -1^3) + 1 = 6 = \dim \tilde{\mathcal{Q}}(2^2, -1^4)$, it follows $\mathcal{M} = \tilde{\mathcal{Q}}(2^2, -1^4)$. The proof of the proposition is now complete. q.e.d.

5.4.2. Case 4.I.b). Recall that in this case we number the horizontal cylinders such that

$$(1) \quad \ell_1 + \ell_2 = \ell_3 + \ell_4.$$

We first observe

Lemma 5.16. *Let \mathcal{M} be a rank two affine manifold in genus three and $M \in \mathcal{M}$ an \mathcal{M} -cylindrically stable horizontally periodic translation surface satisfying Case 4.I.b). Then up to a renumbering of the cylinders respecting (1) one of the following occurs:*

- The equivalence classes are $\{C_1, C_2\}$, $\{C_3\}$, $\{C_4\}$,
- The equivalence classes are $\{C_1, C_3\}$, $\{C_2\}$, $\{C_4\}$,
- The equivalence classes are $\{C_1, C_3\}$, $\{C_2, C_4\}$ and $\ell_1 = \ell_3$ and $\ell_2 = \ell_4$.

Proof. We first notice that the four cylinders cannot all be free since this would contradict the rank two hypothesis. By the homological relation, there cannot be three cylinders in the same equivalence class because it would imply that all of the cylinders are \mathcal{M} -parallel. Similarly, if C_1 and C_2 are \mathcal{M} -parallel, then the homological relation implies that each of C_3 and C_4 is free.

Finally, assume that the equivalence classes are $\{C_1, C_3\}$ and $\{C_2, C_4\}$. Then there exist non-zero real numbers μ and λ such that $\gamma_1 = \mu\gamma_3$ and $\gamma_2 = \lambda\gamma_4$. Combining this with the homological relation yields

$$\mu\gamma_3 + \lambda\gamma_4 = \gamma_3 + \gamma_4.$$

This implies that unless $\mu = \lambda = 1$, there is only one equivalence class of cylinders, which would contradict \mathcal{M} -cylindrical stability. Furthermore, the relation $\mu = \lambda = 1$ implies that there are two pairs of cylinders with equal circumferences. q.e.d.

The following lemma improves Lemma 4.2. Despite its rather technical statement, it will be useful for us in the sequel.

Lemma 5.17. *Let \mathcal{M} be a rank two affine manifold in genus three in a stratum with $k \geq 3$ zeros. Assume that every rank two affine manifold in genus three with at most $k - 1$ zeros admits an involution with four fixed points whose derivative is $-\text{id}$. If \mathcal{M} contains a horizontally periodic surface such that one of the horizontal cylinders is simple and not free, then \mathcal{M} contains an \mathcal{M} -cylindrically stable horizontally periodic surface M satisfying one of the following:*

- (i) *There are three horizontal cylinders, two of which are simple and \mathcal{M} -parallel to each other, and the cylinder decomposition satisfies Case 3.I),*
- (ii) *There are at least four horizontal cylinders three of which are \mathcal{M} -parallel to one another,*
- (iii) *There are at least four horizontal cylinders, one of which is simple and not free.*

Proof. Let M be a horizontally periodic surface in \mathcal{M} with a non-free simple cylinder C_1 . By [AN16, Lem. 2.14], we can suppose that M is a square-tiled surface and \mathcal{M} -cylindrically stable. Since M has at least two equivalence classes of horizontal cylinders, and C_1 is not free, we draw that M has at least three horizontal cylinders. If M has four or more horizontal cylinders then we get the last assertion. Assume from now on that M contains exactly three horizontal cylinders.

We first remark that the cylinder decomposition of M does not satisfy Case 3.II) since in this case all three cylinders are free. It does not satisfy Case 3.III) either by [AN16, Lem. 4.6]. Thus we have a cylinder decomposition in Case 3.I).

Let C_2 be \mathcal{M} -parallel to C_1 . If C_2 is also simple, by [AN16, Lem. 2.11] and [AN16, Lem. 2.15], we know that C_1 and C_2 are \mathcal{M} -parallel and the remaining cylinder is free. Therefore, we get the first assertion.

Assume that C_2 is not simple. Let C_3 denote the remaining horizontal cylinder. Following the arguments in the proof of [AN16, Prop. 5.6] we get two possibilities:

- If C_1 is only adjacent to C_3 , then the conclusion is that we get an equivalence class \mathcal{D} , with at least three vertical cylinders which do not fill M . Thus we have the second assertion.
- If C_1 is adjacent to both C_2 and C_3 , then we have a contradiction.

The proof of the lemma is then complete. q.e.d.

We also need the following

Lemma 5.18. *Let M be an \mathcal{M} -cylindrically stable horizontally periodic surface in \mathcal{M} . If one of the horizontal cylinders of M is simple and not free, then the cylinder decomposition of M does not belong to Case 4.IV).*

Proof. Assume that the cylinder decomposition of M satisfies Case 4.IV). We label the horizontal cylinders by C_1, \dots, C_4 , and let γ_i be a (geodesic) core curve of C_i . Recall that in this case the family $\{\gamma_1, \dots, \gamma_4\}$ cuts M into two three-holed spheres and a two-holed torus. We choose the numbering such that $\gamma_3 \cup \gamma_4$ is the boundary of the two-holed torus. Observe that the following homological relations hold

$$\gamma_1 + \gamma_2 = \gamma_3 = \gamma_4.$$

By cutting M along γ_3 and γ_4 , then exchanging the gluings, we get two translation surfaces of genus two, both of which are horizontally periodic. Observe that one of the two surfaces has a single horizontal cylinder, which is formed by one half of C_3 and one half of C_4 . This observation allows us to conclude that neither C_3 nor C_4 is simple.

By assumption, either C_1 or C_2 is simple and not free. But from the homological relation, it can be easily seen that in either case, all four cylinders belong to the same equivalence class, which contradicts the \mathcal{M} -cylindrical stability of M . q.e.d.

5.4.3. Case 4.I.b): the stratum $\mathcal{H}(2, 1, 1)$. The following lemma follows from an inspection of admissible configurations of G_1 and G_2 .

Lemma 5.19. *There are exactly three cylinder diagrams up to symmetry satisfying Case 4.I.b) in $\mathcal{H}(2, 1^2)$ and they are depicted in Figure 9.*

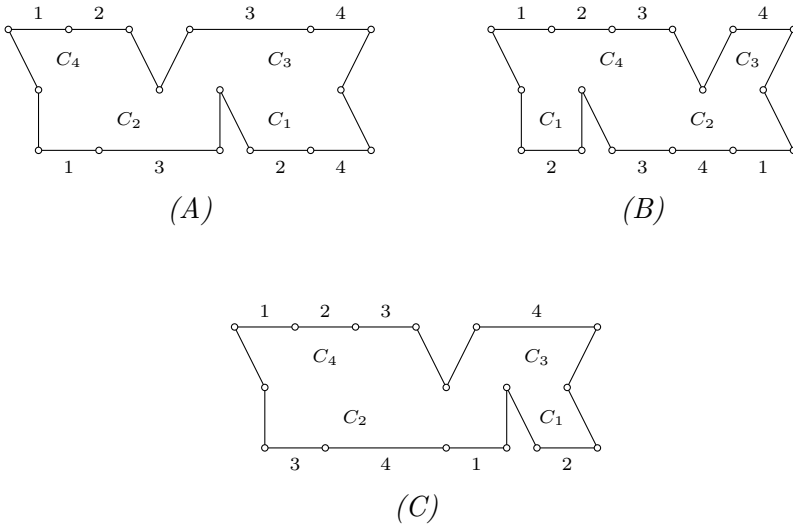

Figure 9. The three cylinder diagrams satisfying Case 4.I.b) in $\mathcal{H}(2, 1, 1)$.

We will show

Proposition 5.20. *Let \mathcal{M} be a rank two affine submanifold of $\mathcal{H}(2, 1^2)$. If \mathcal{M} contains a horizontally periodic surface M satisfying Case 4.I.b), then either \mathcal{M} contains a horizontally periodic surface with five cylinders, or $\mathcal{M} = \tilde{\mathcal{Q}}(2, 1, -1^3)$.*

We first prove

Lemma 5.21. *If \mathcal{M} is a rank two affine manifold in $\mathcal{H}(2, 1^2)$ and $M \in \mathcal{M}$ is horizontally periodic satisfying Case 4.I.b), then M does not have a free semi-simple cylinder.*

Proof. By contradiction, if M has a free semi-simple cylinder C , then one boundary of C contains a double zero and the other must contain one or more simple zeros. Twist C so that it admits a vertical saddle connection, which by necessity connects a double zero to a simple zero. Collapsing C results in a translation surface in a rank two affine manifold in $\mathcal{H}(3, 1)$. Since no such affine manifold exists by [AN16], we achieved the desired contradiction. q.e.d.

Lemma 5.22. *Let \mathcal{M} be a rank two affine manifold in $\mathcal{H}(2, 1^2)$. If $M \in \mathcal{M}$ is an \mathcal{M} -cylindrically stable horizontally periodic satisfying Case 4.I.b), then neither $\{C_1, C_2\}$ nor $\{C_3, C_4\}$ can be equivalence classes.*

Proof. By contradiction, if either of them is an equivalence class, then Lemma 5.21 implies that the other one must be an equivalence class

because each of $\{C_1, C_2\}$ and $\{C_3, C_4\}$ contains a semi-simple cylinder. But this contradicts Lemma 5.16. q.e.d.

Lemma 5.23. *Let \mathcal{M} be a rank two affine submanifold of $\mathcal{H}(2, 1^2)$. Then \mathcal{M} does not contain an \mathcal{M} -cylindrically stable horizontally periodic surface M satisfying Case 4.I.b) with cylinder diagram (C).*

Proof. Assume to a contradiction that \mathcal{M} contains an \mathcal{M} -cylindrically stable horizontally periodic surface satisfying Case 4.I.b) with cylinder diagram (C). We claim that one of C_1, C_3, C_4 is free. Assume that none of them is free, by Lemma 5.22, C_1 must be \mathcal{M} -parallel to either C_3 or C_4 and either $\ell_1 = \ell_3$ or $\ell_1 = \ell_4$ by Lemma 5.16. But clearly, in this case we always have $\ell_1 < \ell_3$ and $\ell_1 < \ell_4$. If one of C_1, C_3, C_4 is free, then we get a contradiction to Lemma 5.21, and the lemma follows. q.e.d.

Lemma 5.24. *Let \mathcal{M} be a rank two affine submanifold of $\mathcal{H}(2, 1^2)$. If \mathcal{M} contains an \mathcal{M} -cylindrically stable horizontally periodic surface M satisfying Case 4.I.b) with cylinder diagram (B), then $\mathcal{M} = \tilde{\mathcal{Q}}(2, 1, -1^3)$.*

Proof. We number the cylinders so that C_1 and C_3 are the simple ones. By Lemma 5.21, neither C_1 nor C_3 are free. From Lemma 5.16, either C_1 is \mathcal{M} -parallel to C_3 and $\ell_1 = \ell_3$, or C_1 is \mathcal{M} -parallel to C_4 and $\ell_1 = \ell_4$. Since the latter cannot happen because $\ell_1 < \ell_4$, we conclude that the equivalence classes of horizontal cylinders are $\{C_1, C_3\}$ and $\{C_2, C_4\}$, and $\ell_1 = \ell_3$ and $\ell_2 = \ell_4$.

We next claim that C_1 and C_3 are similar. If they are not, then after twisting, we can assume that there is a vertical saddle connection in C_1 , but C_3 contains no vertical saddle connections. Collapsing simultaneously C_1 and C_3 yields a surface in $\mathcal{H}(3, 1)$. Since there are no rank two affine submanifolds in $\mathcal{H}(3, 1)$, we get a contradiction.

The previous claim implies that $C_3 = \lambda C_1$, where $\lambda > 0$. Since $\ell_1 = \ell_3$, it follows that $\lambda = 1$. Hence, C_1 and C_3 are isometric. Collapse C_1 and C_3 simultaneously to get a surface $M' \in \mathcal{H}(4)$. By Proposition 2.9, M' is contained in a rank two affine submanifold \mathcal{M}' of $\mathcal{H}(4)$ such that $\dim \mathcal{M} = \dim \mathcal{M}' + 1$.

By the result of [ANW16], $\mathcal{M}' = \tilde{\mathcal{Q}}(3, -1^3)$. Hence, M' admits a Prym involution τ . It is easy to check that this involution permutes the two horizontal cylinders of M' , and exchanges the saddle connections which are the degenerations of C_1 and C_3 . By Proposition 2.10, τ gives rise to an involution of M with four fixed points, which implies that $M \in \tilde{\mathcal{Q}}(2, 1, -1^3)$. Remark that this also holds for all of the surfaces in \mathcal{M} close to M , therefore $\mathcal{M} \subset \tilde{\mathcal{Q}}(2, 1, -1^3)$. Finally, from the dimension count

$$\dim \mathcal{M} = \dim \tilde{\mathcal{Q}}(3, -1^3) + 1 = 5 = \dim \tilde{\mathcal{Q}}(2, 1, -1^3),$$

we conclude that $\mathcal{M} = \tilde{\mathcal{Q}}(2, 1, -1^3)$. q.e.d.

Lemma 5.25. *Let \mathcal{M} be a rank two affine submanifold of $\mathcal{H}(2, 1^2)$. Assume that \mathcal{M} contains a horizontally periodic surface M satisfying Case 4.I.b) with cylinder diagram (A), then either $\mathcal{M} = \tilde{\mathcal{Q}}(2, 1, -1^3)$ or \mathcal{M} contains a horizontally periodic surface with five cylinders.*

Proof. If M is not \mathcal{M} -cylindrically stable, then we conclude that there is a horizontally periodic surface in \mathcal{M} with at least five cylinders. Otherwise, assume M is \mathcal{M} -cylindrically stable. By Lemma 5.21, neither C_1 nor C_4 is free. From Lemma 5.16, we must have two equivalence classes $\{C_1, C_4\}$ and $\{C_2, C_3\}$ such that $\ell_1 = \ell_4$ and $\ell_2 = \ell_3$. Observe that there is a saddle connection in the bottom of C_1 and the top of C_3 , and there is another saddle connection in the top of C_1 and the bottom of C_3 . Since C_1 and C_3 are not \mathcal{M} -parallel, after some twisting, we can assume that there is a vertical simple cylinder D contained in $\overline{C_1} \cup \overline{C_3}$, which crosses each of γ_1 and γ_3 once. Note that D must be \mathcal{M} -parallel to another vertical cylinder crossing C_2 and C_4 .

Applying Lemma 5.17, we derive that \mathcal{M} contains a horizontally periodic surface M_1 that is \mathcal{M} -cylindrically stable, and one of the following occurs

- (i) The cylinder decomposition of M_1 in the horizontal direction satisfies Case 3.I), and two of the cylinders are simple. In this case, we use Proposition 3.1 to conclude that $\mathcal{M} = \tilde{\mathcal{Q}}(2, 1, -1^3)$.
- (ii) M_1 has at least four horizontal cylinders and three of which are \mathcal{M} -parallel. Assume that M_1 has exactly four horizontal cylinders. If the cylinder decomposition satisfies Case 4.I) or Case 4.IV), then we only have one equivalence class, which contradicts the \mathcal{M} -cylindrically stable hypothesis. Case 4.II) is ruled out by Proposition 5.10, and Case 4.III) is also ruled out by Proposition 5.7. Thus in this case M_1 has at least five horizontal cylinders.
- (iii) M_1 has at least four horizontal cylinders, one of which is simple and not free. We only need to consider the case where M_1 has exactly four horizontal cylinders. Again Case 4.II) and Case 4.III) are ruled out by Proposition 5.10 and Proposition 5.7. Case 4.IV) is ruled out by Lemma 5.18. In Case 4.I.a), we conclude by Proposition 5.13. Finally, in Case 4.I.b), since one of the cylinders is simple, we must have Diagram (B) or (C). Thus by Lemma 5.24 or Lemma 5.23, we can conclude that $\mathcal{M} = \tilde{\mathcal{Q}}(2, 1, -1^3)$. q.e.d.

Proof of Proposition 5.20.

Proof. Proposition 5.20 is a direct consequence of Lemmas 5.19, 5.23, 5.24, and 5.25. q.e.d.

5.4.4. Case 4.I.b): the principal stratum $\mathcal{H}(1, 1, 1, 1)$. The following lemma is obtained from a careful inspection of admissible configurations for the graphs G_1 and G_2 .

Lemma 5.26. *There are four diagrams for cylinder decompositions in Case 4.I.b) in the stratum $\mathcal{H}(1^4)$. They are shown in Figure 10.*

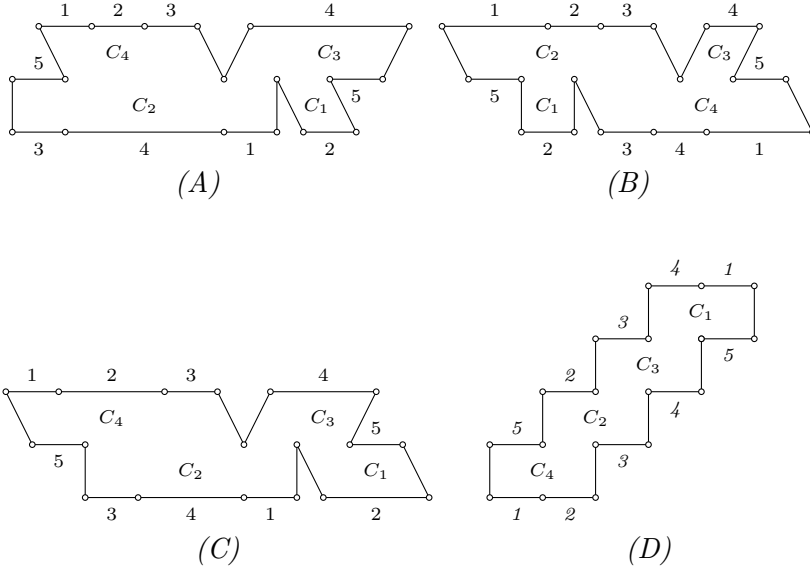

Figure 10. Cylinder Diagrams Satisfying Case 4.I.b) in $\mathcal{H}(1, 1, 1, 1)$.

Lemma 5.27. *Assume that \mathcal{M} contains an \mathcal{M} -cylindrically stable horizontally periodic surface M satisfying Case 4.I.b) with cylinder diagram (A). Then $\mathcal{M} = \tilde{\mathcal{Q}}(2^2, -1^4)$.*

Proof. We number the cylinders so that C_1 is the simple one, and C_3 and C_4 are the semi-simple ones. Recall that the relation (1) always holds. We claim that neither C_3 nor C_4 is free. Suppose that C_3 is free. Since it is semi-simple, we can collapse it to get a surface $M' \in \mathcal{H}(2, 1^2)$. By assumption, M' must belong to $\tilde{\mathcal{Q}}(2, 1, -1^3)$, hence it admits a Prym involution τ with four fixed points. Observe that M' has three horizontal cylinders, and none of them can be permuted with another one by τ . Thus τ must fix all three cylinders, hence it must have at least six fixed points and we get a contradiction. The same arguments apply if C_4 is free.

Using Lemma 5.16, we derive that C_1 must be free and $\{C_3, C_4\}$ is an equivalence class. Collapsing C_1 so that the two zeros in its boundary collide, we obtain a surface $M' \in \tilde{\mathcal{Q}}(2, 1, -1^3)$. In particular, M' admits a Prym involution τ . Since τ has four fixed points, it must fix C_2 and exchange C_3 and C_4 . In particular, it fixes the saddle connection which is the degeneration of C_1 . Therefore, τ extends to a Prym involution of M that fixes C_1 by Proposition 2.10. It follows that $M \in \tilde{\mathcal{Q}}(2^2, -1^4)$, and $\mathcal{M} \subset \tilde{\mathcal{Q}}(2^2, -1^4)$ by Proposition 2.8. Since we

have $\dim \mathcal{M} = \dim \tilde{\mathcal{Q}}(2, 1, -1^3) + 1 = 6 = \dim \tilde{\mathcal{Q}}(2^2, -1^4)$, it follows that $\mathcal{M} = \tilde{\mathcal{Q}}(2^2, -1^4)$. q.e.d.

Lemma 5.28. *Assume that \mathcal{M} contains an \mathcal{M} -cylindrically stable horizontally periodic surface M satisfying Case 4.I.b) with cylinder diagram (B) . Then $\mathcal{M} \in \{\tilde{\mathcal{H}}(1, 1), \tilde{\mathcal{Q}}(2^2, -1^4)\}$.*

Proof. We number the cylinders so that C_1 and C_3 are the simple ones, and C_1 is adjacent to C_2 . Assume that C_1 is free. We can collapse it to get a surface $M' \in \tilde{\mathcal{Q}}(2, 1, -1^3)$ with three horizontal cylinders. Remark that C_1 degenerates to a saddle connection contained in both top and bottom of C_2 .

Since C_3 is the unique horizontal simple cylinder in M' , it must be fixed by τ . Recall that τ has four fixed points, hence it must exchange C_2 and C_4 . But this is impossible since there are no saddle connections that are contained in both top and bottom of C_4 . The same arguments apply for the case C_3 is free. Thus we can conclude that neither C_1 nor C_3 is free.

By Lemma 5.16, we derive that C_1 and C_3 are \mathcal{M} -parallel. Let \mathcal{C} denote the equivalence class $\{C_1, C_3\}$.

We now claim that C_2 and C_4 are not free. Assume that C_2 is free which means that C_4 is also free. Observe that we can twist \mathcal{C} and C_2 such that there is a vertical cylinder D contained in $\overline{C_1} \cup \overline{C_2}$. Since any other vertical cylinder crossing C_2 must cross C_4 , we derive that D is free. But this contradicts the Cylinder Proportion Lemma, since we have $P(C_1, \{D\}) = 1$ but $P(C_3, \{D\}) = 0$. Therefore, we can conclude that C_2 and C_4 are \mathcal{M} -parallel. Using again Lemma 5.16, we draw that $\ell_1 = \ell_3$ and $\ell_2 = \ell_4$.

We next claim that C_1 and C_3 are similar. If they are not, then we can twist them so that C_1 contains a vertical saddle connection, but C_3 does not. Collapsing simultaneously C_1 and C_3 we get a surface $M' \in \tilde{\mathcal{Q}}(2, 1-1^3)$ with two horizontal cylinders. By counting the number of saddle connections on the borders of these two cylinders, we see that they cannot be exchanged by the Prym involution τ' of M' . Thus, they are both fixed by τ' , which implies that τ' has four regular fixed points in M' . Since the double zero of M' must be a fixed point of τ' , we derive that τ' has at least 5 fixed points which is a contradiction.

Since C_1 and C_2 are similar and $\ell_1 = \ell_3$, we conclude that C_1 and C_3 are isometric. Collapsing C_1 and C_3 simultaneously yields a surface $M' \in \mathcal{H}(2, 2)$, which is contained in a rank two affine submanifold \mathcal{M}' . Again, let τ' be the Prym involution of M' , and let σ_1 and σ_3 be respectively the saddle connections which are the degenerations of C_1 and C_3 in M' . Note that σ_1 (resp. σ_3) is contained in both top and bottom of C_2 (resp. C_4).

We claim that τ' exchanges C_2 and C_4 . If τ' fixes C_2 , then it also fixes C_4 , therefore it has four regular fixed points in M' . Moreover, since σ_1 is the unique saddle connection contained in both top and bottom of C_2 , it must be invariant by τ' . But σ_1 connects a zero of M' to itself, therefore τ' fixes a zero of M' . This contradicts the condition that τ' has exactly four fixed points.

Since τ' exchanges C_2 and C_4 , it must exchange σ_1 and σ_3 and permute the zeros of M' . We derive in particular that $M' \in \mathcal{H}^{\text{odd}}(2, 2)$. Thus $\mathcal{M}' = \tilde{\mathcal{H}}_{(2,2)}^{\text{odd}}(2)$ or $\mathcal{M}' = \tilde{\mathcal{Q}}(4, -1^4)$. It follows from Proposition 2.10 that τ' extends to a Prym involution of M . Thus $M \in \tilde{\mathcal{Q}}(2^2, -1^4)$ and $\mathcal{M} \subseteq \tilde{\mathcal{Q}}(2^2, -1^4)$. If $\mathcal{M}' = \tilde{\mathcal{H}}_{(2,2)}^{\text{odd}}(2)$, then M' also admits a hyperelliptic involution, which also extends to M . Hence in this case, we have $\mathcal{M} \subseteq \tilde{\mathcal{H}}(1, 1)$.

By Proposition 2.9, we know that $\dim \mathcal{M} = \dim \mathcal{M}' + 1$. Using this dimension relation, we conclude that if $\mathcal{M}' = \tilde{\mathcal{H}}_{(2,2)}^{\text{odd}}(2)$, then $\mathcal{M} = \tilde{\mathcal{H}}(1, 1)$, and if $\mathcal{M}' = \tilde{\mathcal{Q}}(4, -1^4)$, then $\mathcal{M} = \tilde{\mathcal{Q}}(2^2, -1^4)$. q.e.d.

Lemma 5.29. *Assume that \mathcal{M} contains a horizontally periodic surface M satisfying Case 4.I.b) with cylinder diagram (C) or (D). Then either $\mathcal{M} \in \{\tilde{\mathcal{H}}(1, 1), \tilde{\mathcal{Q}}(2^2, -1^4)\}$, or \mathcal{M} contains a horizontally periodic surface with at least five horizontal cylinders.*

Proof. It suffices to assume that M is \mathcal{M} -cylindrically stable, otherwise, we conclude that \mathcal{M} contains a horizontally periodic surface with at least five cylinders. Using Lemma 5.16, one can check that there always exists a pair of cylinders C_i and C_j which are not \mathcal{M} -parallel such that

- There is a saddle connection σ in the bottom of C_i and in the top of C_j ,
- There is a saddle connection σ' in the top of C_i and in the bottom of C_j ,
- C_i is \mathcal{M} -parallel to another cylinder.

Since C_i and C_j are not \mathcal{M} -parallel, we can twist them so that there is a vertical simple cylinder D contained in $\overline{C}_i \cup \overline{C}_j$ which crosses only σ and σ' . Since C_i is \mathcal{M} -parallel to another cylinder, D is not free. Applying Lemma 5.17, we get a horizontally periodic \mathcal{M} -cylindrically stable surface $M_1 \in \mathcal{M}$, and one of the following occurs:

- (i) There are three horizontal cylinders, two of which are simple, and the cylinder diagram satisfies Case 3.I). In this case we conclude by Proposition 3.1.
- (ii) There are at least four cylinders, and one of the equivalence classes consists of at least three cylinders. If M_1 has five horizontal cylinders or more, we are done. Assume that M_1 has exactly 4 cylinders. By the homological relations and \mathcal{M} -cylindrical stability,

Case 4.IV) and Case 4.I) are ruled out. If the cylinder decomposition satisfies Case 4.II) or Case 4.III), then we conclude by Proposition 5.11 or Proposition 5.7, respectively.

- (iii) There are at least four horizontal cylinders, one of which is simple and not free. Obviously, we only need to consider the case M_1 has exactly 4 cylinders. Case 4.IV) is then ruled out by Lemma 5.18. In Case 4.II) and 4.III), we conclude by Proposition 5.11 and Proposition 5.7, respectively. In Case 4.I.a), we conclude by Proposition 5.15. Finally, in Case 4.I.b), since there exists a simple cylinder, we must have diagrams (A) or (B), and we can use Lemma 5.27 or Lemma 5.28 to conclude. q.e.d.

As a direct consequence of Lemmas 5.26, 5.27, 5.28, and 5.29, we get

Proposition 5.30. *Suppose that $\tilde{Q}(2, 1, -1^3)$ is the unique rank two affine submanifold in $\mathcal{H}(2, 1^2)$. Let \mathcal{M} be a rank two affine submanifold of $\mathcal{H}(1^4)$. Assume that \mathcal{M} contains a horizontally periodic surface M satisfying Case 4.I.b). Then either \mathcal{M} contains a horizontally periodic surface with at least five cylinders, or $\mathcal{M} \in \{\tilde{\mathcal{H}}(1, 1), \tilde{Q}(2^2, -1^4)\}$.*

6. Five cylinders

Lemma 6.1. *If a horizontally periodic genus three translation surface M decomposes into exactly five cylinders, then pinching the core curves of those cylinders degenerates the surface to one of two possible surfaces:*

- 5.I) *Three spheres where two spheres have a pair of simple poles between them and the third sphere has two pairs of simple poles joined to each of the other two spheres.*
- 5.II) *Three spheres where two spheres have three simple poles and the third sphere carries a pair of simple poles.*

Proof. Let X' denote the degenerate Riemann surface. We use the classical terminology *part* to mean a connected component of a degenerate Riemann surface from which the nodes have been removed. Observe that a degenerate Riemann surface with p parts imposes $p - 1$ homological relations on the core curves of parallel cylinders. In particular, there are no homological relations among the core curves of parallel cylinders on a degenerate Riemann surface with one part. Thus, if X' has one part and M consisted of five cylinders, M would have to have genus at least five. Likewise, if X' has two parts and M has five cylinders, then M would have to have genus at least four.

In genus three the degenerate surface X' can never have more than four parts, which is given by the general upper bound $2(g - 1)$.

If X' has four parts and at least one part has positive genus, then the original surface would have genus at least four. This can be seen by replacing the part with positive genus with a sphere with a corresponding number of poles and observing that it arises from a surface

with at least six cylinders and such a configuration can never occur in genus three. Thus, if X' has four parts, then all four parts have genus zero. However, every sphere must carry a meromorphic differential with at least three simple poles, and this would require at least six cylinders. Hence, X' has exactly three parts.

Finally, if X' has three parts, we claim that no part has positive genus because again each part of genus g' can be replaced by a sphere with g' pairs of simple poles. Since each pair of poles corresponds to a pinched cylinder and every six cylinder surface in genus three degenerates to a punctured Riemann surface consisting of exactly four spheres, all three parts of X' must be spheres. Recalling that every sphere must carry a differential with at least three simple poles, we leave the reader to deduce that there are exactly two possibilities. q.e.d.

As usual, we denote by C_1, \dots, C_5 the horizontal cylinders of M , and for $i = 1, \dots, 5$, γ_i is a core curve of C_i . We choose the orientation of γ_i to be from the left to the right.

6.1. Case 5.I.) In Case 5.I) there is a unique cylinder between the spheres with three simple poles. Throughout this subsection we call that cylinder C_1 . We choose a numbering of the cylinders such that the following homological relations hold

$$(2) \quad \gamma_1 = \epsilon_2\gamma_2 + \epsilon_3\gamma_3 = \epsilon_4\gamma_4 + \epsilon_5\gamma_5,$$

where $\epsilon_i \in \{\pm 1\}$.

Let us denote by x_1 and x_2 the two simple zeros in the spheres with three simple poles. If $M \in \mathcal{H}(2, 1^2)$, we denote by x_0 the double zero, and if $M \in \mathcal{H}(1^4)$ we denote the two simple zeros on the sphere with four simple poles by x'_0 and x''_0 . For $i = 1, 2$, we denote by G_i the graph which is the union of horizontal saddle connections containing x_i . We denote by G_0 the graph consisting of horizontal saddle connections in the sphere with four simple poles. Note that by assumption, the graphs G_i , $i = 0, 1, 2$, are *planar*. The admissible configurations of G_i are shown in Figure 11.

Recall that in the literature the union $G := \sqcup_{i=0}^2 G_i$ is called the *separatrix diagram* of M , and in particular has a *ribbon structure* (see [KZ03, Sec. 4]). Let U_i be a regular neighborhood of G_i in the plane. We fix the orientation of every edge of G_i to be from left to right. Each component of ∂U_i is a core curve of a horizontal cylinder which is freely homotopic to a union of edges of G_i .

A component of ∂U_i is said to be *simple* if it is (freely) homotopic to a single edge of G_i , which must be loop. By definition, the cylinders that contain a simple component of ∂U_i are semi-simple.

6.1.1. The stratum $\mathcal{H}(2, 1, 1)$. No horizontally periodic translation surface in $\mathcal{H}(2, 1^2)$ can have more than five cylinders, so throughout

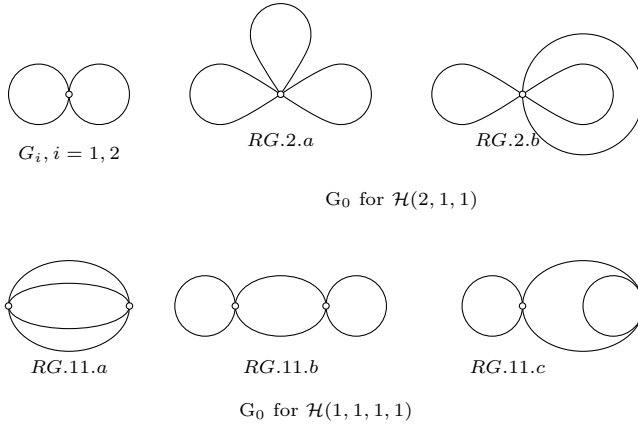

Figure 11. Case 5.I): admissible configurations of G_i , $i = 0, 1, 2$.

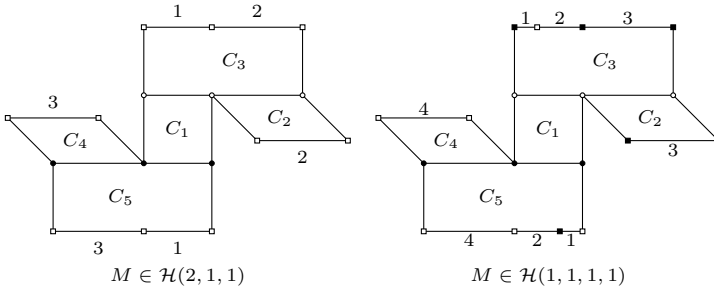

Figure 12. Some cylinder diagrams in Case 5.I).

this subsection, M is always \mathcal{M} -cylindrically stable. We will prove the following proposition.

Proposition 6.2. *If $\mathcal{M} \subset \mathcal{H}(2, 1^2)$ is a rank two affine manifold and $M \in \mathcal{M}$ admits a cylinder decomposition satisfying Case 5.I), then $\mathcal{M} = \tilde{\mathcal{Q}}(2, 1, -1^3)$.*

Lemma 6.3. *Let M be a translation surface satisfying Case 5.I) in a rank two affine manifold $\mathcal{M} \subset \mathcal{H}(2, 1^2)$. Then C_1 is free.*

Proof. By contradiction, assume that C_1 is not free. Let \mathcal{C} be the equivalence class of C_1 . From the relation (2), we derive that if $C_2 \in \mathcal{C}$, then $C_3 \in \mathcal{C}$ and vice versa. The same is true for the pair $\{C_4, C_5\}$. By assumption, the cylinders must split into two or three equivalence classes. Thus, without loss of generality we can assume that $\mathcal{C} = \{C_1, C_2, C_3\}$ and C_4 and C_5 are free.

We now claim that at least one of C_4 or C_5 is semi-simple. To see this, we observe that the boundaries of C_4 and C_5 contain the same simple zero. We can assume that this simple zero is x_1 . Since the graph

G_1 is planar, we see that among three cylinders $\{C_1, C_4, C_5\}$, there are two that are semi-simple. Thus at least one of C_4 and C_5 is semi-simple.

Collapsing the free semi-simple cylinder yields a translation surface which is contained in a rank two affine submanifold \mathcal{M}' of $\mathcal{H}(3, 1)$ by [AN16, Prop. 2.16]. But such a submanifold does not exist by [AN16]. Hence, we get a contradiction. q.e.d.

Lemma 6.4. *Let M be a translation surface in \mathcal{M} which admits a cylinder decomposition in the horizontal direction satisfying Case 5.I). Then up to a renumbering of the cylinders, the equivalence classes are $\{C_1\}$, $\{C_2, C_4\}$, $\{C_3, C_5\}$.*

Proof. By Lemma 6.3, we know that one of the equivalence classes is $\{C_1\}$. If C_2 and C_3 are \mathcal{M} -parallel, then their equivalence class would contain C_1 , and we have a contradiction. The argument of Lemma 6.3 actually shows that C_2 and C_3 cannot both be free. Let us assume that C_2 is free and C_3 is \mathcal{M} -parallel to C_5 . Since C_4 cannot be \mathcal{M} -parallel to C_5 (otherwise it would be \mathcal{M} -parallel to C_1), C_4 must be free. But in this case, we would have three free cylinders C_1, C_2, C_4 whose core curves span a Lagrangian subspace of $H_1(M, \mathbb{R})$, which contradicts the hypothesis that \mathcal{M} is of rank two. Thus the only possibility remaining is that C_2 is \mathcal{M} -parallel to C_4 , and C_3 is \mathcal{M} -parallel to C_5 . q.e.d.

Lemma 6.5. *Following the convention of Lemma 6.4, one of the equivalence classes $\{C_2, C_4\}$ and $\{C_3, C_5\}$ consists of two simple cylinders.*

Proof. We first consider the case C_1 is simple. Up to a renumbering of the cylinders, we have

$$\gamma_1 = \gamma_2 - \gamma_3 = \pm(\gamma_4 - \gamma_5) \Rightarrow \gamma_2 - \gamma_3 + \epsilon(\gamma_4 - \gamma_5) = 0 \in H_1(M, \mathbb{Z}),$$

where $\epsilon \in \{\pm 1\}$. By Lemma 6.4, there exist constants $\lambda, \mu \in \mathbb{R}_{>0}$ such that $\gamma_4 = \lambda\gamma_2$ and $\gamma_5 = \mu\gamma_3$ as elements of $(T_M\mathcal{M})^*$. It follows

$$(1 + \epsilon\lambda)\gamma_2 - (1 + \epsilon\mu)\gamma_3 = 0 \in (T_M\mathcal{M})^*.$$

If one of $\{1 + \epsilon\lambda, 1 + \epsilon\mu\}$ does not vanish, then C_2 and C_3 are \mathcal{M} -parallel, and we have a contradiction. Thus we must have $\epsilon = -1$ and $\lambda = \mu = 1$. It follows that

$$(3) \quad |\gamma_2| = |\gamma_4|, |\gamma_3| = |\gamma_5|, \text{ and } \gamma_1 = \gamma_2 - \gamma_3 = \gamma_4 - \gamma_5 \in H_1(M, \mathbb{Z}).$$

Note that the relation (3) implies

$$(4) \quad \gamma_2 - \gamma_3 - \gamma_4 + \gamma_5 = 0 \in H_1(M, \mathbb{Z})$$

and it follows that $\gamma_2 - \gamma_3 - \gamma_4 + \gamma_5$ is homologous to ∂U_0 . Therefore the configuration of G_0 is given by RG.2.b (see Figure 11).

We now claim that C_3 is a simple cylinder. Without loss of generality, we can assume that the top of C_3 is contained in G_0 , while its bottom is contained in G_1 . From (3), we draw that $|\gamma_3| < |\gamma_2|$ and the bottom of

C_3 contains a single saddle connection. If C_3 is not simple then its top must contain exactly two saddle connections since it is homotopic to a component of ∂U_0 . Note that the relation (4) implies that the top of C_4 is also contained in G_0 . Since a saddle connection cannot be contained in the top of two cylinders, it follows that the top of C_4 consists of a single saddle connection. But this saddle connection is contained in the bottom of C_2 or C_5 . Thus we must have either $|\gamma_4| < |\gamma_2|$, or $|\gamma_4| < |\gamma_5|$. In either case we have a contradiction to (3). Therefore, the top of C_3 must contain a single saddle connection, which means that C_3 is simple.

By similar arguments, C_5 is also simple, and the lemma is proved for this case.

Let us consider the case C_1 is semi-simple (but not simple). In this case, we have

$$\gamma_1 = \gamma_2 - \gamma_3 = \gamma_4 + \gamma_5 \Rightarrow \gamma_2 - \gamma_3 - \gamma_4 - \gamma_5 = 0 \in H_1(M, \mathbb{Z}).$$

It follows that the configuration of G_0 is given by *RG.2.a* (see Figure 11). Let λ, μ be the constants above, we have

$$(1 - \lambda)\gamma_2 = (1 + \mu)\gamma_3 \in (T_M\mathcal{M})^*.$$

Thus C_2 and C_3 are \mathcal{M} -parallel, which contradicts Lemma 6.4. Therefore, this case does not occur.

Finally, consider the case C_1 is not semi-simple. In this case, the relation (2) gives

$$(5) \quad \gamma_1 = \gamma_2 + \gamma_3 = \gamma_4 + \gamma_5, \text{ and } \gamma_2 + \gamma_3 - \gamma_4 - \gamma_5 = 0 \in H_1(M, \mathbb{Z}).$$

Hence the configuration of G_0 is given by *RG.2.b*. In particular ∂U_0 has two simple components. Since these two simple components are paired with some simple components of $\partial U_1 \sqcup \partial U_2$, the corresponding cylinders are simple. We will show that they must be \mathcal{M} -parallel. Let λ, μ be the constants above. We have

$$(1 - \lambda)\gamma_2 + (1 - \mu)\gamma_3 = 0 \in (T_M\mathcal{M})^*.$$

If one of $\{1 - \lambda, 1 - \mu\}$ does not vanish, then C_2 and C_3 are parallel which contradicts Lemma 6.4. Thus we must have $|\gamma_2| = |\gamma_4|$, and $|\gamma_3| = |\gamma_5|$. Without loss of generality we can assume that the top of C_2 is contained in G_0 . The relation (5) implies that G_0 contains the top of C_3 and the bottoms of C_4 and C_5 . Let σ_0, σ_1 , and σ_2 be the saddle connections in G_0 . We are done unless, without loss of generality, the top of C_2 is $\sigma_0 \cup \sigma_1$ and the bottom of C_5 is $\sigma_1 \cup \sigma_2$. It follows that the top of C_3 is σ_2 and the bottom of C_4 is σ_0 . However, the relations above imply $|\sigma_0| + |\sigma_1| = |\sigma_0|$ and $|\sigma_2| = |\sigma_1| + |\sigma_2|$, which is impossible. q.e.d.

Proof of Proposition 6.2. By Lemma 6.5, we can assume that C_2 and C_4 are two \mathcal{M} -parallel simple cylinders. We claim that they are similar. If they are not, twist them so that there is a vertical saddle connection

in C_2 , but there are no vertical saddle connections in C_4 . Collapsing the equivalence class $\{C_2, C_4\}$ yields a surface M' which is contained in a rank two submanifold of $\mathcal{H}(3, 1)$ by [AN16, Prop. 2.16]. But there are no affine submanifolds of rank two in $\mathcal{H}(3, 1)$, and we have a contradiction.

Since the pairs of zeros in the boundaries of C_2 and C_4 are not the same, collapsing them simultaneously so that all of the zeros collide yields a surface $M' \in \mathcal{H}(4)$. By Proposition 2.9, M' is contained in a rank two affine submanifold $\mathcal{M}' \subset \mathcal{H}(4)$ such that $\dim \mathcal{M}' = \dim \mathcal{M} - 1$. By the results of [NW14, ANW16], we have $\mathcal{M}' = \tilde{\mathcal{Q}}(3, -1^3)$. Hence, M' admits a Prym involution τ' .

Note that C_2 and C_4 degenerate to two horizontal saddle connections σ'_2 and σ'_4 in M' . We claim that σ'_2 and σ'_4 are permuted by τ' . If they are not, then there is a surface $M'_1 \in \tilde{\mathcal{Q}}(3, -1^3)$ close to M' in which they are **not** parallel. But from Proposition 2.9, these saddle connections are the degenerations of two parallel cylinders in a surface $M_1 \in \mathcal{M}$ close to M , hence must be parallel. Thus we get a contradiction.

Since σ'_2 and σ'_4 are permuted by τ' , they must have the same length, which implies that C_2 and C_4 are isometric. By Proposition 2.10, τ' extends to an involution with four fixed points on M . The same holds for any surface in a neighborhood of $M \in \mathcal{M}$. It follows that $\mathcal{M} \subseteq \mathcal{P} \cap \mathcal{H}(2, 1, 1) = \tilde{\mathcal{Q}}(2, 1, -1^3)$. Finally, since

$$\dim \mathcal{M} = \dim \tilde{\mathcal{Q}}(3, -1^3) + 1 = 5 = \dim \tilde{\mathcal{Q}}(2, 1, -1^3),$$

we can conclude that $\mathcal{M} = \tilde{\mathcal{Q}}(2, 1, -1^3)$. q.e.d.

6.1.2. The principal stratum $\mathcal{H}(1, 1, 1, 1)$. The key to this section is studying the cylinder C_1 . The main result of this section is

Proposition 6.6. *Let $\mathcal{M} \subset \mathcal{H}(1^4)$ be a rank two affine manifold. Assume that $\tilde{\mathcal{Q}}(2, 1, -1^3)$ is the only rank two affine manifold in $\mathcal{H}(2, 1^2)$. If \mathcal{M} contains a horizontally periodic surface M satisfying Case 5.I), then either there exists $M' \in \mathcal{M}$ horizontally periodic with six cylinders or $\mathcal{M} = \tilde{\mathcal{Q}}(2^2, -1^4)$.*

We first prove the following lemmas

Lemma 6.7. *Following the notation and assumption of Proposition 6.6, either \mathcal{M} contains a horizontally periodic surface with six cylinders or the cylinder C_1 is free.*

Proof. If M is not \mathcal{M} -cylindrically stable, then we can get a horizontally periodic surface with more cylinders, so in this case we are done. Assume that M is \mathcal{M} -cylindrically stable. If C_1 is not free, then by the same arguments as Lemma 6.3, we see that there are two free cylinders among $\{C_2, \dots, C_5\}$, and that one of them is semi-simple. Collapsing the free semi-simple cylinder, yields a surface $M' \in \mathcal{H}(2, 1^2)$

which is contained in a rank two affine submanifold \mathcal{M}' . By assumption, $\mathcal{M}' = \tilde{\mathcal{Q}}(2, 1, -1^3)$, hence M' admits a Prym involution which fixes the double zero and permutes the simple ones. But in this case, one of the simple zeros is joined to the double zero by a horizontal saddle connection whereas the other one is not. Therefore we get a contradiction which proves the lemma. q.e.d.

Lemma 6.8. *Either the equivalence classes of horizontal cylinders in M are $\{C_1\}, \{C_2, C_3\}, \{C_4, C_5\}$ or M contains a horizontally periodic surface with six cylinders.*

Proof. We only need to consider the case when M is \mathcal{M} -cylindrically stable, which implies that the cylinders of M fall into at least two equivalence classes. By Lemma 6.7, one of the equivalence classes is $\{C_1\}$. It follows that C_2 and C_3 are not \mathcal{M} -parallel. If both C_2 and C_3 are free, then we can conclude by the arguments of Lemma 6.7. Consider the case where C_2 is free but C_3 is not. We can assume that C_3 is \mathcal{M} -parallel to C_5 . It follows that C_4 is free. But the core curves of C_1, C_2, C_4 span a Lagrangian subspace of dimension 3 in $H_1(M, \mathbb{Z})$, which contradicts the hypothesis that \mathcal{M} is of rank two. We can then conclude that C_2 is \mathcal{M} -parallel to C_4 , and C_3 is \mathcal{M} -parallel to C_5 up to a renumbering of the cylinders. q.e.d.

Lemma 6.9. *Assume that M is \mathcal{M} -cylindrically stable. Then C_1 is not strictly semi-simple.*

Proof. If C_1 is strictly semi-simple, then up to a renumbering of the cylinders, we have

$$\gamma_1 = \gamma_2 - \gamma_3 = \gamma_4 + \gamma_5 \Rightarrow \gamma_2 - \gamma_3 - \gamma_4 - \gamma_5 = 0 \in H_1(M, \mathbb{Z}).$$

From Lemma 6.8, there exist constants $\lambda, \mu \in \mathbb{R}_{>0}$, such that

$$\gamma_4 = \lambda\gamma_2, \quad \gamma_5 = \mu\gamma_3 \in (T_M\mathcal{M})^*.$$

Consequently

$$(1 - \lambda)\gamma_2 = (1 + \mu)\gamma_3 \in (T_M\mathcal{M})^*.$$

Since $1 + \mu > 0$, this means that C_2 and C_3 are \mathcal{M} -parallel, which contradicts Lemma 6.4. Therefore, C_1 cannot be semi-simple. q.e.d.

Lemma 6.10. *There are two cylinder diagrams in which C_1 is not semi-simple which are shown in Figure 13.*

Proof. If C_1 is not semi-simple, then each of C_2, \dots, C_5 are semi-simple because the identifications between each of the cylinders at C_1 is completely determined. The remaining identifications can be deduced from Lemma 5.26. q.e.d.

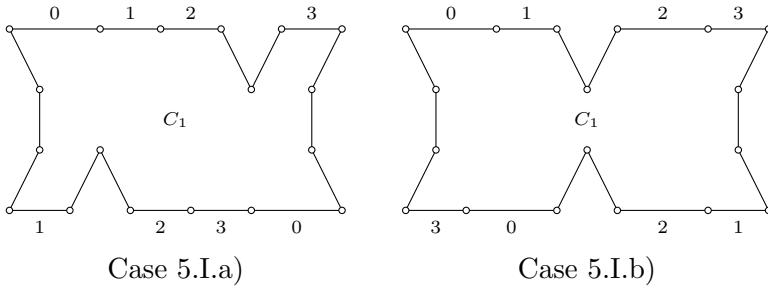

Figure 13. The two cylinder diagrams in $\mathcal{H}(1^4)$ satisfying Case 5.I) where C_1 is not semi-simple.

Proof of Proposition 6.6.

Proof. It suffices to assume that M is \mathcal{M} -cylindrically stable, otherwise we are done. By Lemma 6.7, we know that C_1 is free, and from Lemma 6.9, we only need to consider two cases:

C_1 is simple. Collapsing C_1 so that the two zeros in its boundary collide yields a surface $M' \in \mathcal{H}(2, 1^2)$ which is contained in a rank two affine submanifold \mathcal{M}' by [AN16, Prop. 2.16]. By assumption, $\mathcal{M}' = \tilde{\mathcal{Q}}(2, 1, -1^3)$, thus M' admits a Prym involution τ' .

Let x'_0 be the double zero of M' . Observe that all the horizontal saddle connections starting from x'_0 end at x'_0 . Let us denote those saddle connections by $\sigma_0, \sigma_1, \sigma_2$, where σ_0 is the degeneration of C_1 . Since C_1 is not \mathcal{M} -parallel to any other cylinder, we can choose M such that $|\sigma_0| \neq |\sigma_1|$ and $|\sigma_0| \neq |\sigma_2|$. Since τ' fixes x'_0 , it induces a permutation of $\{\sigma_0, \sigma_1, \sigma_2\}$. We claim that σ_0 is invariant by τ' , since otherwise we have either $|\sigma_0| = |\sigma_1|$ or $|\sigma_0| = |\sigma_2|$ contradicting our assumption. We can now use Proposition 2.10 to conclude that $M \in \mathcal{P} \cap \mathcal{H}(1^4) = \tilde{\mathcal{Q}}(2^2, -1^4)$, and hence $\mathcal{M} \subseteq \tilde{\mathcal{Q}}(2^2, -1^4)$. Since we have

$$\dim \mathcal{M} = \dim \tilde{\mathcal{Q}}(2, 1, -1^3) + 1 = \dim \tilde{\mathcal{Q}}(2^2, -1^4) = 6,$$

it follows that $\mathcal{M} = \tilde{\mathcal{Q}}(2^2, -1^4)$.

C_1 is not semi-simple. There are two cylinder diagrams to consider by Lemma 6.10. In this case, each saddle connection in the boundary of C_1 is one component of the boundary of a cylinder in the family $\{C_2, \dots, C_5\}$. Let us denote those saddle connections by $\sigma_2, \dots, \sigma_5$ such that σ_i is one boundary component of C_i . Since C_2 is not \mathcal{M} -parallel to C_5 by Lemma 6.8, M can be chosen such that $|\sigma_2| \neq |\sigma_5|$. It follows that C_1 can be twisted such that it contains only one vertical saddle connection joining two distinct zeros in its boundary. Collapsing C_1 yields a surface $M' \in \mathcal{H}(2, 1^2)$ which is contained in a rank two affine submanifold by [AN16, Prop. 2.16]. By assumption, this submanifold must be $\tilde{\mathcal{Q}}(2, 1, -1^3)$. Thus M' admits a Prym involution. By inspecting

the cylinder diagram of M' , we see that this Prym involution extends to a Prym involution of M that fixes C_1 . In particular, $M \in \mathcal{P} \cap \mathcal{H}(1^4) = \tilde{\mathcal{Q}}(2^2, -1^4)$.

We now claim that $\mathcal{M} \subseteq \tilde{\mathcal{Q}}(2^2, -1^4)$. To see this choose a small positive real number ϵ such that, for any $v \in T_M^{\mathbb{R}}\mathcal{M} \subset H^1(M, \Sigma, \mathbb{R})$ such that $\|v\| < \epsilon$, we have $M_v := M + v \in \mathcal{M}$ and the condition $|\sigma_2| \neq |\sigma_5|$ still holds. Here, we identify M with an element of $H^1(X, \Sigma, \mathbb{R} + i\mathbb{R})$. Remark that since v is purely real, all the horizontal saddle connections of M remain horizontal in M_v , which means that M_v is also horizontally periodic with the same cylinder diagram as M . By the same argument as above, we have $M_v \in \tilde{\mathcal{Q}}(2^2, -1^4)$. Therefore, we have

$$T_M^{\mathbb{R}}\mathcal{M} \subseteq T_M^{\mathbb{R}}\tilde{\mathcal{Q}}(2^2, -1^4),$$

which implies that $\mathcal{M} \subseteq \tilde{\mathcal{Q}}(2^2, -1^4)$. In particular, we have $\dim \mathcal{M} \leq \dim \tilde{\mathcal{Q}}(2^2, -1^4) = 6$. We now notice that by [AN16, Prop. 2.16], we must have

$$\dim \mathcal{M} > \dim \tilde{\mathcal{Q}}(2, 1, -1^3) = 5.$$

Thus, it follows $\dim \mathcal{M} = \dim \tilde{\mathcal{Q}}(2^2, -1^4) = 6$ and $\mathcal{M} = \tilde{\mathcal{Q}}(2^2, -1^4)$. The proof of Proposition 6.6 is now complete. q.e.d.

6.2. Case 5.II). We label the cylinders so that C_1 and C_2 are the homologous cylinders, and C_5 is the unique cylinder which degenerates to a pair of simple poles in the same component of the limit surface (which is obtained as one pinches all of the horizontal cylinders).

Cutting M along the core curves of C_1 and C_2 , then permuting the gluings, we get two translation surfaces of genus two. Let us denote by M^1 the surface that contains C_3 and C_4 , and by M^2 the surface that contains C_5 . In particular, C_3, C_4, C_5 can be realized as cylinders in a translation surface of genus two. Therefore, the cylinder diagrams in this case can be constructed by considering the unique 3-cylinder diagram in $\mathcal{H}(1, 1)$, and the 2-cylinder diagrams in $\mathcal{H}(2)$ and $\mathcal{H}(1, 1)$.

Let γ_i denote the core curve of C_i oriented from left to right. We have either $\gamma_1 + \gamma_3 = \gamma_4$, or $\gamma_3 + \gamma_4 = \gamma_1$. Our goal in this section is to show

Proposition 6.11. *Let \mathcal{M} be rank two affine submanifold of rank two in $\mathcal{H}(2, 1^2) \cup \mathcal{H}(1^4)$. Assume that \mathcal{M} contains a horizontally periodic surface M satisfying Case 5.II), then*

- (i) *If $\mathcal{M} \subset \mathcal{H}(2, 1^2)$, then $\mathcal{M} = \tilde{\mathcal{Q}}(2, 1, -1^3)$.*
- (ii) *If $\mathcal{M} \subset \mathcal{H}(1^4)$ and $\tilde{\mathcal{Q}}(2, 1, -1^3)$ is the unique rank two submanifold in $\mathcal{H}(2, 1^2)$, then either \mathcal{M} contains a horizontally periodic surface with six cylinders, or $\mathcal{M} = \tilde{\mathcal{Q}}(2^2, -1^4)$.*

Let us start by proving some conditions that the cylinders in M must satisfy.

Lemma 6.12. *Let $M \in \mathcal{M}$ be a horizontally periodic surface satisfying Case 5.II). If M is \mathcal{M} -cylindrically stable, then C_5 is free.*

Proof. For $i = 1, \dots, 5$, let us denote by ξ_i the vector in $H^1(M, \Sigma, \mathbb{R}) \simeq T_M^{\mathbb{R}}\mathcal{M}$ tangent to the path defined by the twisting of C_i . By Poincaré duality, up to a non-zero constant, ξ_i can be identified with γ_i , where γ_i is an element of $H_1(M \setminus \Sigma, \mathbb{R})$ (see [MW17, Sect. 4.1]). Since the projection $p : H^1(M, \Sigma, \mathbb{R}) \rightarrow H^1(M, \mathbb{R})$ is dual to the map $p' : H_1(M \setminus \Sigma, \mathbb{R}) \rightarrow H_1(M, \mathbb{R})$, we see that $p(\xi_i)$ is dual to $\lambda_i \gamma_i \in H_1(M, \mathbb{R})$, with $\lambda_i \in \mathbb{R} \setminus \{0\}$.

The assumption of Case 5.II) means that we have the following homological relations

$$\gamma_1 = \gamma_2 = \gamma_3 + \gamma_4,$$

and $\{\gamma_3, \gamma_4, \gamma_5\}$ span a Lagrangian in $H_1(M, \mathbb{R})$.

By assumption we have at least two equivalence classes of horizontal cylinders. Assume that C_5 is not free. If C_5 is \mathcal{M} -parallel to $\{C_1, C_2\}$, then C_3 and C_4 must be free because otherwise we only have one equivalence class. It follows that $T_M^{\mathbb{R}}\mathcal{M}$ contains the vectors $\{\xi_1 + \xi_2 + \xi_5, \xi_3, \xi_4\}$. Thus $p(T_M^{\mathbb{R}}\mathcal{M})$ contains the duals of $\{\lambda_1 \gamma_1 + \lambda_2 \gamma_2 + \lambda_5 \gamma_5, \gamma_3, \gamma_4\}$. But as this family spans a Lagrangian (of dimension 3) in $H_1(M, \mathbb{R}) \simeq H^1(M, \mathbb{R})$, we get a contradiction to the hypothesis that \mathcal{M} is of rank two. Thus this case cannot occur.

Assume now that C_5 is \mathcal{M} -parallel to either C_3 or C_4 . By the homological relations, it follows that one of C_3 and C_4 is free, and $\{C_1, C_2\}$ is an equivalence class. We can suppose that $\{C_4, C_5\}$ is an equivalence class and C_3 is free. By the same argument as above, $p(T_M^{\mathbb{R}}\mathcal{M})$ contains the duals of the vectors $\gamma_1, \gamma_3, \lambda_4 \gamma_4 + \lambda_5 \gamma_5 \in H_1(M, \mathbb{R})$. Since $\{\gamma_1, \gamma_3, \gamma_5\}$ spans a Lagrangian in $H_1(M, \mathbb{R})$, and $\gamma_4 = \gamma_1 - \gamma_3$, we see that the family $\{\gamma_1, \gamma_3, \lambda_4 \gamma_4 + \lambda_5 \gamma_5\}$ also spans a Lagrangian in $H_1(M, \mathbb{R})$. Hence we also have contradiction in this case, which shows that C_5 must be free. q.e.d.

Lemma 6.13. *The equivalence classes of cylinders on M are $\{C_1, C_2, C_3, C_4\}$ and $\{C_5\}$.*

Proof. Lemma 6.12 proves that one of the equivalence classes is $\{C_5\}$. It remains to show that C_3 and C_4 are \mathcal{M} -parallel to C_1 and C_2 . If one of them is \mathcal{M} -parallel to $\{C_1, C_2\}$, then so is the other. Thus we only need to rule out the case when they are both free. But this follows already from the arguments of Lemma 6.12. q.e.d.

Lemma 6.14. *The cylinders C_3 and C_4 are simple.*

Proof. Recall that C_3 and C_4 are two cylinders in a 3-cylinder decomposition of a surface in $\mathcal{H}(1, 1)$. Thus at least one of them, say C_3 , must be simple. If C_4 is not simple, then the boundary of C_3 is contained in the boundary of C_4 . But since C_3 and C_4 are \mathcal{M} -parallel,

this contradicts [AN16, Lem. 2.11]. Therefore, both C_3, C_4 must be simple. q.e.d.

There are two admissible cylinder diagrams for Case 5.II) in $\mathcal{H}(2, 1^2)$, which are shown in Figure 14.

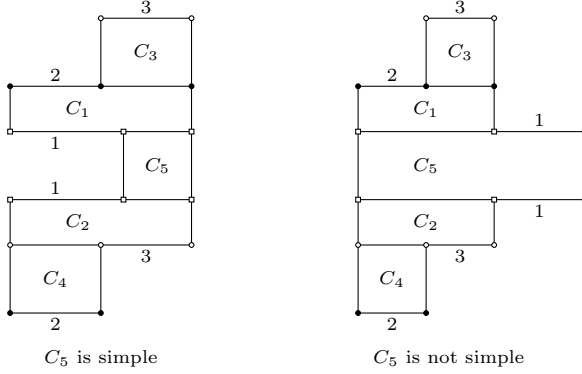

Figure 14. Case 5.II) in $\mathcal{H}(2, 1, 1)$: Admissible cylinder diagrams.

6.2.1. Proof of Proposition 6.11: case $\mathcal{M} \subset \mathcal{H}(2, 1^2)$.

Proof. Note that in this case $M^1 \in \mathcal{H}(1, 1)$ and $M^2 \in \mathcal{H}(2)$. In particular, either C_5 is a simple cylinder, or there exists a saddle connection which is contained in both its top and bottom. Let x_0 denote the double zero of M , and x_1, x_2 denote the simple ones. For $i \in \{1, \dots, 5\}$, let h_i and l_i denote respectively the height, and the circumference of C_i . Without loss of generality, let $h_1 \leq h_2$.

Case C_5 is simple. We will perform an extended cylinder deformation to show that in fact, $h_1 = h_2$ and that C_1 and C_2 must simultaneously admit vertical saddle connections. Then we will collapse to $\mathcal{H}(4)$ to conclude.

Let σ_5 and σ'_5 denote respectively the top and bottom borders of C_5 . We can assume that σ_5 is contained in the bottom of C_1 . Remark that the top of C_1 contains a unique zero of M , which can be supposed to be x_1 . Twist the cylinders in the equivalence class $\{C_1, \dots, C_4\}$ such that none of the descending vertical rays from the copies of x_1 in the top of C_1 hits a copy of x_0 in the bottom of C_1 before exiting C_1 , and one of those rays intersects the interior of σ_5 . We can then twist C_5 such that this ray hits x_0 after crossing C_5 . We then have a vertical saddle connection δ from x_0 to x_1 crossing C_5 and C_1 . Note that we have $|\delta| = h_5 + h_1$.

Consider now the deformations of M by stretching C_5 . These deformations define a path in \mathcal{M} whose tangent vector $\xi \in H^1(M, \Sigma; i\mathbb{R})$

satisfies $\xi(c) = \iota\langle \gamma_5, c \rangle$ for any $c \in H_1(M, \Sigma; \mathbb{Z})$, where $\langle \cdot, \cdot \rangle$ is the intersection form (see [Wri15, Lem. 2.4]).

The path in \mathcal{M} corresponding to this family of deformations is $M + I\xi$, where I is an interval of \mathbb{R} , and M is identified with an element of $H^1(M, \Sigma; \mathbb{R} + \imath\mathbb{R})$. Recall that \mathcal{M} is locally identified with an open subset of a linear subspace V of $H^1(M, \Sigma; \mathbb{R} + \imath\mathbb{R})$. Since $M \in V$ and $\xi \in V$, we have $M + t\xi \in V$. Hence as long as $M_t := M + t\xi$ corresponds to a surface in $\mathcal{H}(2, 1, 1)$, this surface must belong to \mathcal{M} .

Observe now that when $t = -h_5$, the cylinder C_5 degenerates to the union of two horizontal saddle connections. Consider now M_t for $t \in (-(h_1 + h_5), -h_5)$. We first observe that for those values of t , C_3 and C_4 are not affected by the deformations, M_t remains horizontally periodic and always satisfies Case 5.II). The cylinders C_1 and C_2 give rise to two homologous cylinders on M_t , which will be denoted by C'_1 and C'_2 respectively, and there is an additional horizontal cylinder that we denote by C'_5 (see Figure 15). The bottom of C'_1 (resp. the top of C'_2) consists of a single saddle connection, and the new C'_5 is not simple. The heights of C'_1, C'_2 , and C'_5 are given by $h_1 + h_5 + t, h_2 + h_5 + t$, and $h_5 - t$ respectively. Such M_t are called *extended cylinder deformations* of M and are described in [AN16, Sec. 4.2].

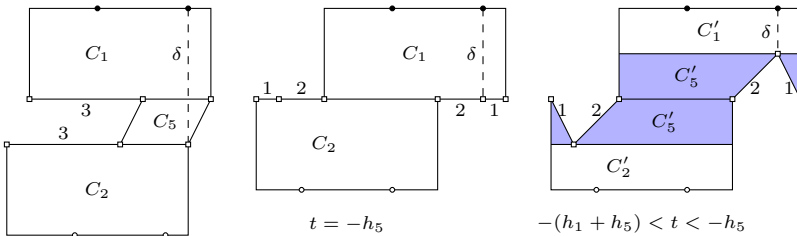

Figure 15. Extended Cylinder Deformation for Case 5.II) in $\mathcal{H}(2, 1, 1)$, C_5 is simple.

By construction the saddle connection δ remains vertical in M_t , and its length is given by $h_1 + h_5 + t$. As t tends to $-(h_1 + h_5)$, δ shrinks to a point, which means that x_0 and x_1 collide. If $h_2 > h_1$ then no other collision of zeros occurs, and the resulting surface, denoted by M' , belongs to $\mathcal{H}(3, 1)$ (which can easily be checked by hand). One can now use the arguments of [AN16, Prop. 2.16] to conclude that M' must be contained in a rank two affine submanifold of $\mathcal{H}(3, 1)$. But since such a submanifold does not exist by the results of [AN16], we get a contradiction.

Assume from now on that $h_1 = h_2$. Consider again the limit surface M' as t tends to $-(h_1 + h_5)$. One can easily check that M' is a translation surface of genus three. If there is no vertical saddle connection in C'_2 , then $M' \in \mathcal{H}(3, 1)$ and we get again a contradiction. If C'_2 contains a

vertical saddle connection, then this one is unique, and in the limit the three zeros of M collide, and the resulting surface M' belongs to $\mathcal{H}(4)$.

By [MW17, Cor. 1.2], M' is contained in an affine manifold \mathcal{M}' of rank at most two. Observe that since the cylinder C'_5 on M_t is free, it must also be free on M' with respect to \mathcal{M}' . Thus \mathcal{M}' must be an affine manifold of rank two. By the results of [ANW16, NW14], M' must belong to the Prym locus $\tilde{\mathcal{Q}}(3, -1^3)$. In particular, M' admits a Prym involution. Observe that this involution exchanges C_3 and C_4 , which means that C_3 and C_4 are isometric. It is now easy to check that the Prym involution of M' extends to a Prym involution on M_t , for any $t \in (-(h_1 + h_5), -h_5)$. Therefore we have $M_t \in \tilde{\mathcal{Q}}(2, 1, -1^3)$.

Choose $t \in (-(h_1 + h_5), -h_5)$ and consider the surface $M_t + v$, where $v \in T_{M_t}^{\mathbb{R}}\mathcal{M}$ is a vector in a neighborhood of 0. By the same arguments as above, we see that $M_t + v \in \tilde{\mathcal{Q}}(2, 1, -1^3)$ (remark that if $M_t \in \tilde{\mathcal{Q}}(2, 1, -1^3)$, then twisting simultaneously the equivalence class of C'_1 also gives a surface in $\tilde{\mathcal{Q}}(2, 1, -1^3)$). It follows that $T_{M_t}^{\mathbb{R}}\mathcal{M} \subseteq T_{M_t}^{\mathbb{R}}\tilde{\mathcal{Q}}(2, 1, -1^3)$, hence $\mathcal{M} \subseteq \tilde{\mathcal{Q}}(2, 1, -1^3)$. Since we also have

$$\begin{aligned} \dim \mathcal{M} &> \dim \tilde{\mathcal{Q}}(3, -1^3) \Rightarrow \\ \dim \mathcal{M} &\geq \dim \tilde{\mathcal{Q}}(3, -1^3) + 1 = \dim \tilde{\mathcal{Q}}(2, 1, -1^3), \end{aligned}$$

we conclude that $\mathcal{M} = \tilde{\mathcal{Q}}(2, 1, -1^3)$.

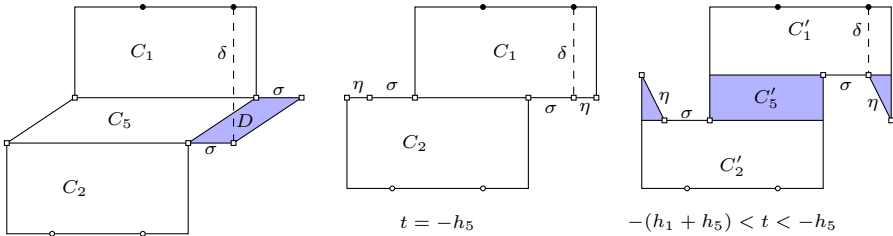

Figure 16. Extended Cylinder Deformations for Case 5.II) in $\mathcal{H}(2, 1, 1)$, C_5 is not simple.

Case C_5 is not simple. In this case C_1 and C_2 are semi-simple, and there is a saddle connection σ which is contained in both the top and bottom of C_5 . Let D be a simple cylinder in the closure of C_5 that contains σ . Since C_5 is free, so is D . By stretching D , we can assume that the length of σ is smaller than the length of any other horizontal saddle connection. Twist C_1 such that all of the descending vertical rays from the singularities in its top (there are two such rays) do not hit the singularity in its bottom. Twist C_5 so that one of those rays hits x_0 after crossing C_5 , but the other one does not (see Figure 16).

Consider the extended cylinder deformations along the vector corresponding to the stretching of C_5 . It is straightforward to verify that

the same arguments as the previous case allow us to conclude that $\mathcal{M} = \tilde{\mathcal{Q}}(2, 1, -1^3)$. q.e.d.

6.2.2. Proof of Proposition 6.11: case $\mathcal{M} \subset \mathcal{H}(1, 1, 1, 1)$.

Proof.

Case C_5 is simple. By Lemma 2.7, the zeros of M in the top and bottom of C_5 are distinct. Since C_5 is free by Lemma 6.12, collapse it so that these two zeros collide to yield a surface $M' \in \mathcal{H}(2, 1, 1)$. By Proposition 2.8, M' is contained in a rank two affine submanifold \mathcal{M}' of $\mathcal{H}(2, 1, 1)$ such that $\dim \mathcal{M} = \dim \mathcal{M}' + 1$. By assumption, we have $\mathcal{M}' = \tilde{\mathcal{Q}}(2, 1, -1^3)$, and in particular M' admits a Prym involution τ' . Since the degeneration of C_5 on M' is a saddle connection which is fixed by τ' , by Proposition 2.10, this Prym involution extends to a Prym involution of M . Thus we have $M \in \tilde{\mathcal{Q}}(2^2, -1^4)$. Since the same holds for any surface in \mathcal{M} close enough to M , we conclude that $\mathcal{M} \subseteq \tilde{\mathcal{Q}}(2^2, -1^4)$. Finally, by a dimension count

$$\dim \mathcal{M} = \dim \tilde{\mathcal{Q}}(2, 1, -1^3) + 1 = \dim \tilde{\mathcal{Q}}(2^2, -1^4),$$

we conclude that $\mathcal{M} = \tilde{\mathcal{Q}}(2^2, -1^4)$.

Case C_5 is not simple. In this case, the closure of C_5 contains a simple cylinder whose core curve crosses C_5 once. Let D be such a simple cylinder. By twisting C_5 , we can assume that D is vertical. It is not difficult to check that D is free because any other vertical cylinder D' which crosses C_5 must cross either C_1 or C_2 , which would contradict Lemma 6.12. The remainder of the proof follows from the same lines as the previous case. q.e.d.

6.3. Proof of Theorem 1.3: Part I.

Proof. Let \mathcal{M} be a rank two affine manifold in $\mathcal{H}(2, 1, 1)$. By Proposition 4.1 Part (1), there exists a horizontally periodic surface with at least four cylinders. By Proposition 5.2(a) we reduce to the case of horizontally periodic surfaces with five cylinders. Let $M \in \mathcal{M}$ be a horizontally periodic surface with five cylinders. By Lemma 6.1, M satisfies Case 5.I) or Case 5.II). In either case, Proposition 6.2 or Proposition 6.11 allows us to conclude that $\mathcal{M} = \tilde{\mathcal{Q}}(2, 1, -1^3)$. The first part of Theorem 1.3 is then proved. q.e.d.

7. Six cylinders

This section obviously only concerns the principal stratum in genus three. We remark that there is no longer a need to assume that $\tilde{\mathcal{Q}}(2, 1, -1^3)$ is the only rank two affine manifold in $\mathcal{H}(2, 1, 1)$ because this fact has been established in Section 6.3. Furthermore, since no horizontally periodic surface in genus three can have more than six cylinders, M is \mathcal{M} -cylindrically stable throughout this section.

Proposition 7.1. *There are four 6-cylinder diagrams in genus three, they are shown in Figure 17.*

Proof. See Appendix C.

q.e.d.

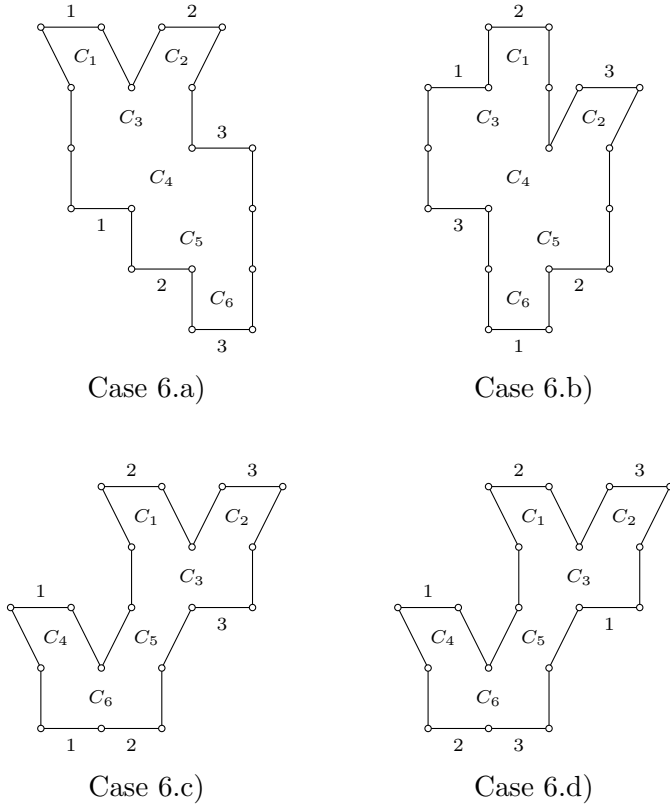

Figure 17. The Four 6-Cylinder Diagrams.

Throughout this section γ_i denotes the homology class of the core curve of the cylinder C_i oriented from left to right, for $i = 1, \dots, 6$.

Lemma 7.2 (Case 6.a). *Let \mathcal{M} be a rank two affine manifold in $\mathcal{H}(1^4)$. If \mathcal{M} contains a horizontally periodic surface M satisfying Case 6.a) (see Figure 17), then $\mathcal{M} = \tilde{\mathcal{Q}}(2^2, -1^4)$.*

Proof. Observe that the following homological equations hold:

$$\begin{aligned} \gamma_1 + \gamma_2 &= \gamma_3 \\ \gamma_2 + \gamma_6 &= \gamma_5 \\ \gamma_1 + \gamma_5 &= \gamma_4 \\ \gamma_3 + \gamma_6 &= \gamma_4. \end{aligned}$$

If C_1 is free, then we can collapse it to get a surface $M' \in \mathcal{H}(2, 1, 1)$ which must be contained in $\tilde{\mathcal{Q}}(2, 1, -1^3)$. In particular, M' has a Prym

involution. Observe that this involution must exchange C_2 and C_6 and fix C_4 . Since C_6 is adjacent to C_4 while C_2 is not, such an involution cannot exist, and we have a contradiction. The same argument also yields a contradiction if C_6 is free.

If C_1 is \mathcal{M} -parallel to C_2 or C_3 , then $\{C_1, C_2, C_3\}$ is an equivalence class. From the homological relations and fact that M is \mathcal{M} -cylindrically stable, all of the other cylinders are free. But the possibility that C_6 is free has been excluded by the argument above. If C_1 is \mathcal{M} -parallel to C_4 or C_5 , then $\{C_1, C_4, C_5\}$ is an equivalence class and all of the remaining cylinders are free. Thus we also get a contradiction.

Finally, consider the case where C_1 is \mathcal{M} -parallel to C_6 . We can twist $\{C_1, C_6\}$ so that there is a vertical saddle connection in C_1 , then collapse this equivalence class simultaneously. If there is no vertical saddle connection in C_6 , the collapsing yields a surface $M' \in \mathcal{H}(2, 1, 1)$ which must be contained in $\tilde{\mathcal{Q}}(2, 1, -1^3)$. But it is easy to see that M' cannot admit a Prym involution since the cylinders corresponding to C_3 and C_5 on M' are strictly semi-simple cylinders that contain different numbers of saddle connections in their boundaries. We thus get a contradiction, which means that C_1 contains a vertical saddle connection if and only if C_6 does, which means that C_1 and C_6 are similar.

By Proposition 2.9, collapsing $\{C_1, C_6\}$ simultaneously yields a surface which is contained in a rank two affine submanifold \mathcal{M}' in $\mathcal{H}(2, 2)$ such that $\dim \mathcal{M} = \dim \mathcal{M}' + 1$. We now remark that the cylinder diagram of M' satisfies Case 4.I.OB) (see [AN16, Sec. 6.4]), thus $M' \in \mathcal{H}^{\text{odd}}(2, 2)$ and $\mathcal{M}' = \tilde{\mathcal{Q}}(4, -1^4)$ by [AN16, Lem. 6.16]. Since C_1 and C_6 degenerate to two saddle connections that are exchanged by the Prym involution of M' , it follows from Proposition 2.10 that M also admits a Prym involution and so does any surface in \mathcal{M} close enough to M . We thus have $\mathcal{M} \subseteq \tilde{\mathcal{Q}}(2^2, -1^4)$. From the dimension count

$$\dim \mathcal{M} = \dim \tilde{\mathcal{Q}}(4, -1^4) + 1 = \dim \tilde{\mathcal{Q}}(2^2, -1^4) = 6,$$

we conclude that $\mathcal{M} = \tilde{\mathcal{Q}}(2^2, -1^4)$. q.e.d.

Lemma 7.3 (Case 6.b). *Let \mathcal{M} be a rank two affine manifold in $\mathcal{H}(1^4)$. If \mathcal{M} contains a horizontally periodic surface M satisfying Case 6.b) in Figure 17, then $\mathcal{M} = \tilde{\mathcal{Q}}(2^2, -1^4)$.*

Proof. Observe that the homological equations hold:

$$\begin{aligned} \gamma_1 + \gamma_6 &= \gamma_3 = \gamma_5, \\ \gamma_2 + \gamma_3 &= \gamma_4. \end{aligned}$$

If C_2 is free, we can collapse it and conclude by Theorem 1.3 Part I, and Proposition 2.10.

If C_2 is \mathcal{M} -parallel to either C_3 , C_4 , or C_5 , $\{C_2, C_3, C_4, C_5\}$ is an equivalence class, and C_1, C_6 are free. Hence, C_1 can be collapsed to

a saddle connection σ on a translation surface M' in $\tilde{\mathcal{Q}}(2, 1, -1^3) \subset \mathcal{H}(2, 1, 1)$ satisfying Case 5.II). The Prym involution τ' on M' necessarily fixes C_2 and C_4 , which implies that τ' has at least 4 regular fixed points. But the double zero of M' must also be fixed points. Therefore τ' has at least 5 fixed points and we have a contradiction.

If C_2 is \mathcal{M} -parallel to C_1 , then the homological relations imply that $\{C_1, C_2\}$ is an equivalence class of cylinders because otherwise all cylinders would be in the same equivalence class. For the same reason $\{C_3, C_5\}$ is an equivalence class, and C_4 and C_6 are each free. Collapsing C_6 results in a surface M' satisfying Case 5.II) in $\tilde{\mathcal{Q}}(2, 1, -1^3)$. As above, we also get a contradiction. Finally, if C_2 is \mathcal{M} -parallel to C_6 , then the same argument holds with C_1 playing the role of C_6 in the preceding argument. Thus the lemma follows. q.e.d.

Lemma 7.4 (Case 6.c). *Let \mathcal{M} be a rank two affine manifold in $\mathcal{H}(1^4)$. If \mathcal{M} contains a horizontally periodic surface M satisfying Case 6.c) in Figure 17, then $\mathcal{M} \in \{\tilde{\mathcal{H}}(1, 1), \tilde{\mathcal{Q}}(2^2, -1^4)\}$.*

Proof. Observe that the homological equations hold:

$$\begin{aligned} \gamma_1 + \gamma_2 &= \gamma_3, \\ \gamma_4 + \gamma_5 &= \gamma_6, \\ \gamma_1 + \gamma_2 &= \gamma_5 + \gamma_2 \Leftrightarrow \gamma_1 = \gamma_5. \end{aligned}$$

We claim that C_2 is not free. If C_2 is free, then collapse it to obtain a surface M' satisfying Case 5.II) in $\tilde{\mathcal{Q}}(2, 1, -1^3) \subset \mathcal{H}(2, 1, 1)$. Observe that the Prym involution τ' of M' must fix C_3 and a simple cylinder. Thus τ' has at least 4 regular fixed points. Since the double zero of M' must also be a fixed point of τ' , we get a contradiction.

If C_2 were \mathcal{M} -parallel to C_1 , C_3 , or C_5 , then the homological equations would imply that C_4 is free, and we could collapse it to get the same contradiction as above.

If C_2 were \mathcal{M} -parallel to C_6 , then $\{C_2, C_6\}$ would be an equivalence class of cylinders as would $\{C_1, C_5\}$ by the homological equations. However, if C_3 were \mathcal{M} -parallel to C_4 , then all cylinders would be in the same equivalence class because

$$\gamma_2 + \gamma_6 = \gamma_3 + \gamma_4.$$

Hence, C_4 is free and we achieve the same contradiction as above.

Finally, consider the case where C_2 is \mathcal{M} -parallel to C_4 . Then $\{C_2, C_4\}$ is an equivalence class. We can twist and collapse this equivalence class so that the two zeros in the boundary of C_2 collide. If the two zeros in the boundary of C_4 do not collide, we obtain a surface in $\tilde{\mathcal{Q}}(2, 1, -1^3) \subset \mathcal{H}(2, 1, 1)$. But it is easy to check that this surface does not admit a Prym involution and we get a contradiction. Therefore C_2 contains a vertical saddle connection if and only if C_4 does, which

means that C_2 and C_4 are similar. Collapsing C_2 and C_4 simultaneously yields a surface M' in $\mathcal{H}(2, 2)$ with a cylinder diagram satisfying Case 4.II.OB). It follows in particular that $M' \in \mathcal{H}^{\text{odd}}(2, 2)$ (cf. [AN16, Sec. 6.4]).

By Proposition 2.9, M' is contained in a rank two affine submanifold $\mathcal{M}' \subset \mathcal{H}^{\text{odd}}(2, 2)$ such that $\dim \mathcal{M} = \dim \mathcal{M}' + 1$. By the main results of [AN16], we have $\mathcal{M}' \in \{\tilde{\mathcal{Q}}(4, -1^4), \tilde{\mathcal{H}}_{(2,2)}^{\text{odd}}(2)\}$. In both cases, M' admits a Prym involution τ' . Observe that the degenerations of C_2 and C_4 on M' are two saddle connections that are exchanged by τ' . Thus by Proposition 2.10, τ' extends to a Prym involution of M , and the same is true for any surface in \mathcal{M} close enough to M . Thus we have $\mathcal{M} \subseteq \tilde{\mathcal{Q}}(2^2, -1^4)$.

If $\mathcal{M}' = \tilde{\mathcal{Q}}(4, -1^4)$, then by the dimension count, we have

$$\dim \mathcal{M} = \dim \tilde{\mathcal{Q}}(4, -1^4) + 1 = \dim \tilde{\mathcal{Q}}(2^2, -1^4) = 6,$$

which implies that $\mathcal{M} = \tilde{\mathcal{Q}}(2^2, -1^4)$.

If $\mathcal{M}' = \tilde{\mathcal{H}}_{(2,2)}^{\text{odd}}(2)$, then M' also admits a hyperelliptic involution ι' . We now observe that the saddle connections which are the degenerations of C_2 and C_4 are both invariant by ι' . Again, by Proposition 2.10 we see that ι' extends to a hyperelliptic involution of M . Thus $M \in \mathcal{H}(1^4) \cap \mathcal{P} \cap \mathcal{L} = \tilde{\mathcal{H}}(1, 1)$. Since the same is true for any surface in \mathcal{M} close enough to M , we have $\mathcal{M} \subseteq \tilde{\mathcal{H}}(1, 1)$. Finally, since we have

$$\dim \mathcal{M} = \dim \tilde{\mathcal{H}}_{(2,2)}^{\text{odd}}(2) + 1 = \dim \tilde{\mathcal{H}}(1, 1) = 5,$$

\mathcal{M} must be $\tilde{\mathcal{H}}(1, 1)$. The proof of the lemma is now complete. q.e.d.

Lemma 7.5 (Case 6.d). *Let \mathcal{M} be a rank two affine submanifold in $\mathcal{H}(1^4)$. If \mathcal{M} contains a horizontally periodic surface M satisfying Case 6.d) in Figure 17, then $\mathcal{M} \in \{\tilde{\mathcal{H}}(1, 1), \tilde{\mathcal{Q}}(2^2, -1^4)\}$.*

Proof. Observe that the homological equations hold:

$$\begin{aligned} \gamma_1 + \gamma_2 &= \gamma_3 = \gamma_6, \\ \gamma_4 + \gamma_5 &= \gamma_3. \end{aligned}$$

If C_1 is free, then it can be collapsed and we conclude by Theorem 1.3, Part I, and Proposition 2.10 that $\mathcal{M} = \tilde{\mathcal{Q}}(2^2, -1^4)$.

By contradiction, if C_1 is \mathcal{M} -parallel to C_2 , C_3 , or C_6 , then the homological equations imply that C_4 is free (otherwise, all six cylinders would lie in the same equivalence class). Collapsing C_4 to get a surface in $\mathcal{H}(2, 1, 1)$ allows us to conclude that $\mathcal{M} = \tilde{\mathcal{Q}}(2^2, -1^4)$ by the same argument above.

If C_1 is \mathcal{M} -parallel to C_4 , then the homological equations imply that $\{C_1, C_4\}$ is an equivalence class. By twisting and collapsing C_1 and C_4 , we reach a surface M' in a lower stratum: $\mathcal{H}(2, 1, 1)$ or $\mathcal{H}(2, 2)$. If $M' \in \mathcal{H}(2, 1, 1)$ then from Theorem 1.3, Part I, we have $M' \in \tilde{\mathcal{Q}}(2, 1, -1^3)$.

Observe that if C_1 and C_4 are not similar, then one of C_1 and C_4 degenerates to a single saddle connection, while the other one degenerates to the union of two saddle connections. Hence, we can suppose that in M' , the top of C_3 contains two saddle connections, and the top of C_6 contains three saddle connections.

If M' admits an involution whose derivative is $-\text{id}$, then this involution must exchange C_3 and C_6 , and fix C_2 and C_5 . However, such an involution has at least 5 fixed points (4 regular ones in the interiors of C_2 and C_5 , and the double zero of M'). Thus it cannot be a Prym involution. This contradiction shows that C_1 contains a vertical saddle connection if and only if C_4 does, which implies that C_1 and C_4 are similar. The remainder of the proof then follows from the same lines as Lemma 7.4. q.e.d.

7.1. Proof of Theorem 1.3: Part II. We now have all the necessary materials to complete the proof of Theorem 1.3.

Proof. From Theorem 1.3: Part I, we know that $\tilde{Q}(2, 1, -1^3)$ is the only rank two affine manifold contained in $\mathcal{H}(2, 1, 1)$. By Proposition 2.17, $\tilde{\mathcal{H}}(1, 1)$ is connected, and $\tilde{Q}(2^2, -1^4)$ is connected by the results of [Lan08].

Let \mathcal{M} be a rank two affine manifold in $\mathcal{H}(1^4)$. By Proposition 4.1 Part (2), there exists a horizontally periodic surface $M \in \mathcal{M}$ with at least four cylinders. By Proposition 5.2, we can reduce the case of surface with at least five cylinders.

Assume now that M has five horizontal cylinders. Then M must satisfy Case 5.I) or Case 5.II) by Lemma 6.1. In both cases, either \mathcal{M} contains a horizontally periodic surface with six cylinders, or $\mathcal{M} = \tilde{Q}(2^2, -1^4)$ by Propositions 6.6 and 6.11: Part 2.

Finally, consider the case where M has six horizontal cylinders. Note that in this case the hypothesis that M is \mathcal{M} -cylindrically stable is automatically satisfied. The cylinder diagram of M must satisfy one of four cylinder diagrams by Proposition 7.1, and we conclude by Lemmas 7.2, 7.3, 7.4, and 7.5. Having addressed all possible cases, the proof of the theorem is complete. q.e.d.

Appendix A. Proof of Lemma 5.6

We first need the following two lemmas. In what follows we will use the same notation and conventions as in Section 5.2.

Lemma A.1. *If M is \mathcal{M} -cylindrically stable and M satisfies Case 4.III), then there are at least two saddle connections in the top of C_4 .*

Proof. Suppose that the top C_4 contains only one saddle connection denoted by σ_0 . Let x_1 denote the unique zero contained in the top of C_4 .

We first claim that if C_4 is simple, then the zero in the bottom of C_4 is not x_1 . If $M \in \mathcal{M}(1^4)$, then this follows from Lemma 2.7. Assume that $M \in \mathcal{H}(2, 1^2)$, then x_1 must be the double zero. Let σ_1 be the unique saddle connection in the bottom of C_4 and assume that σ_1 also joins x_1 to itself. Note that σ_1 must be contained in the top of C_1 or C_2 . Without loss of generality, let σ_1 be contained in the top of C_2 . Clearly, the top C_2 must contain other saddle connections.

If the top of C_2 contains exactly two saddle connections, then we have another horizontal saddle connection σ_2 joining x_1 to itself. Since we have found three horizontal saddle connections joining x_1 to itself, there is no saddle connection from x_1 to the remaining zero of M , which contradicts the condition that the graph G is connected. Thus the top of C_2 contains at least three saddle connections. Since the total number of horizontal saddle connections is 7, we derive that the top of C_1 contains only one saddle connection, which must be contained in the bottom of C_3 . But this contradicts [AN16, Lem. 2.11], thus we can conclude that the zero in the bottom of C_4 is not x_1 .

If the bottom of C_4 contains more than one saddle connection, by similar arguments, one can easily show that it must contain a zero x_2 different from x_1 .

Now, since C_4 is free, we can collapse it so that x_1 and x_2 collide, the resulting surface M' is contained in some rank two affine submanifold \mathcal{M}' of a stratum with 2 or 3 zeros in genus three. Note that x_0 remains in M' , hence M' has at least a simple zero. Since there are no rank two affine submanifolds in $\mathcal{H}(3, 1)$, we only have to consider the case $M' \in \mathcal{H}(2, 1^2)$ which means that $M \in \mathcal{H}(1^4)$, and the collision of x_1 and x_2 gives rise to the double zero x of M' .

Let x'_0 be the other simple zero of M' . By assumption, $\mathcal{M} = \tilde{\mathcal{Q}}(2, 1, -1^3)$, thus M admits a Prym involution τ . Note that τ must fix x and exchange x_0 and x'_0 . By the hypothesis, there are no horizontal saddle connections joining x_0 to x , but there are some saddle connections (in the boundary of C_4) that connect x to x'_0 . Therefore, we have a contradiction and the lemma follows. q.e.d.

Lemma A.2. *With the same assumption as Lemma A.1, there is a saddle connection contained in the top of C_1 and the bottom of C_3 if and only if there is a saddle connection contained in the top of C_2 and the bottom of C_3 .*

Proof. Assume that there is a saddle connection σ in the top of C_1 and the bottom of C_3 , then one can twist C_3 (and simultaneously C_1 and C_2) such that C_3 is represented by a rectangle in the plane, and σ is the first saddle connection from the left in its bottom. Note that σ also occurs in the top of C_1 . It is not difficult to see that there always exists a simple closed geodesic crossing only C_1 and C_3 that intersects σ at one point. Let D denote the cylinder associated to this geodesic. Since

C_2 is \mathcal{M} -parallel to C_1 , there must exist another cylinder D' which is \mathcal{M} -parallel to D . Since D is contained in the closure of $C_1 \cup C_3$, D' can only cross C_1, C_2, C_3 . In particular, as a core curve of D' exits C_2 through the top, it must enter C_3 , which implies that there is a saddle connection in the top of C_2 and the bottom of C_3 .

Since the arguments are completely symmetric, conversely, if there exists a saddle connection in the top of C_2 and the bottom of C_3 , then there must exist a saddle connection in the top of C_1 and the bottom of C_3 . q.e.d.

Proof of Lemma 5.6. Assume that there exists a surface $M \in \mathcal{M}$ horizontally periodic satisfying Case 4.III) such that M is \mathcal{M} -cylindrically stable. Let k be the total number of horizontal saddle connections of M . Note that if $M \in \mathcal{H}(2, 1^2)$, then $k = 7$, and if $M \in \mathcal{H}(1^4)$, then $k = 8$. Let k_i be the number of saddle connections contained in the top of C_i . By assumption, we have $k_3 = 2$, and by Lemma A.1, we have $k_4 \geq 2$, therefore $2 \leq k_1 + k_2 \leq 4$.

Recall that we need to show that either the closure of C_4 contains a free simple cylinder with two distinct zeros in its boundary, or C_4 is a semi-simple cylinder.

• Case $k_1 + k_2 = 2$. Note that we must have $k_1 = k_2 = 1$. If the saddle connection in the top of C_1 is contained in the bottom of C_3 , then so is the saddle connection in the top of C_2 by Lemma A.1. But this would imply that the bottom of C_3 only contains those two saddle connections (by comparing the lengths of the two boundary components of C_3), which is impossible since we have four cylinders. By Lemma A.2, we deduce that the tops of both C_1 and C_2 are contained in the bottom of C_4 . It follows that the bottom of C_3 is contained in the top of C_4 .

Assume that $M \in \mathcal{H}(2, 1^2)$ then $k_4 = 3$. If the bottom of C_3 contains three saddle connections, then it equals the top of C_4 , which means that C_3 and C_4 are homologous, but this is excluded by the hypothesis of Case 4.III). By inspection, we also see that the bottom of C_3 cannot contain exactly two saddle connections. Therefore, we are left with the case where the bottom of C_3 contains only one saddle connection. It follows that there are two saddle connections which are contained in both the top and bottom of C_4 . Since $M \in \mathcal{H}(2, 1^2)$, there must exist a saddle connection in the top of C_4 connecting the double zero to a simple one. Let D be a simple cylinder in $\overline{C_4}$ consisting of simple closed geodesics crossing this saddle connection (see Figure 18 left). It is not difficult to see that D is free and the lemma is proved for this case.

Let us now consider the case $k_4 = 4$, which means that $M \in \mathcal{H}(1^4)$. Again, by a careful inspection, one can show that the bottom of C_3 contains only one saddle connection. The unique cylinder diagram corresponding to this case is shown in Figure 18 right. We can also easily

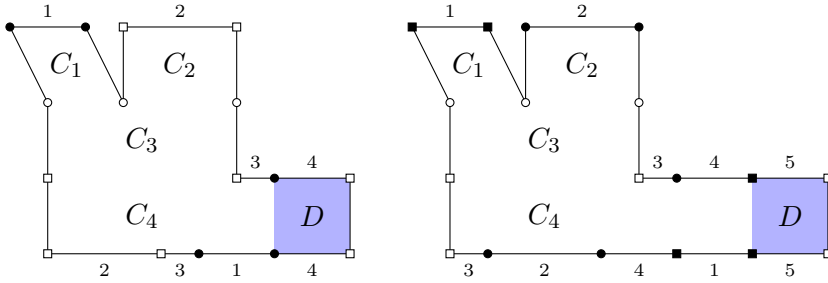

Figure 18. Case 4.III): C_1 and C_2 are simple in $\mathcal{H}(2, 1^2)$ (left) and $\mathcal{H}(1^4)$ (right).

show that there is a free simple cylinder D contained in \overline{C}_4 , whose boundary contains two distinct zeros.

- Case $k_1 + k_2 = 3$. Up to a renumbering, we can assume that $k_1 = 1$ and $k_2 = 2$. We first notice that the top of C_1 cannot be contained in the bottom of C_3 otherwise we have a contradiction to [AN16, Lem. 2.11]. Thus the top of C_1 must be contained in the bottom of C_4 . It follows from Lemma A.2 that both saddle connections in the top of C_2 are contained in the bottom of C_4 . Consequently, the bottom of C_3 must be contained in the top of C_4 .

If $k_4 = 2$, that is $M \in \mathcal{H}(2, 1^2)$, then the bottom of C_3 contains a single saddle connection. The unique corresponding cylinder diagram corresponding to this is shown in Figure 19 (left). Observe that there is a free simple cylinder D contained in \overline{C}_4 . Remark that the boundary of D contains only the double zero of M . Twisting C_4 and simultaneously $\{C_1, C_2, C_3\}$ and using the fact that square-tiled surfaces are dense in \mathcal{M} , we can assume that M is square-tiled and there is a vertical cylinder D_1 crossing only C_1, C_3, C_4 . Note that D_1 fills C_1 and is disjoint from D and C_2 . There must exist vertical cylinders D_2, \dots, D_s , \mathcal{M} -parallel to D_1 that fill C_2 . But it is easy to see that one of the cylinders in the family $\{D_2, \dots, D_s\}$ must intersect D . Since D_1 does not intersect D , this is a contradiction which means that this case cannot occur.

If $k_4 = 3$, that is $M \in \mathcal{H}(1^4)$, then by a careful inspection, we also have that the bottom of C_3 only contains one saddle connection. Hence, there are two saddle connections contained in both the top and bottom of C_4 . Let D be the simple cylinder in \overline{C}_4 as shown Figure 19 (right), then one can easily show that D is free and we are done.

- Case $k_1 + k_2 = 4$. We have $k_4 \in \{1, 2\}$. By Lemma A.1, we know that $k_4 = 2$ and $M \in \mathcal{H}(1^4)$. If there is a saddle connection that is contained in both top and bottom of C_4 , then we have a free simple cylinder D in \overline{C}_4 whose boundary contains two distinct zeros and the lemma follows.

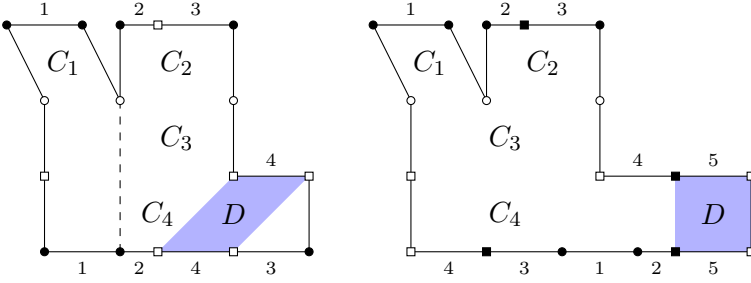

Figure 19. Case 4.III): C_1 is simple and C_2 is semi-simple.

Assume from now on that there is no saddle connection that is contained in both top and bottom of C_4 .

Claim 1: *The top of either C_1 or C_2 cannot be entirely contained in the bottom of C_4 .*

Proof. If the top of either C_1 or C_2 is contained in the bottom of C_4 , then by the proof of Lemma A.2 the tops of both C_1 and C_2 are contained in the bottom of C_4 . In this case, the bottom of C_4 must contain a saddle connection not in the tops of C_1 and C_2 since otherwise we would have C_3 and C_4 homologous. Such a saddle connection must be also contained in the top of C_4 which contradicts our hypothesis. q.e.d.

Claim 2: *We have $k_1 = k_2 = 2$.*

Proof. Assume that $k_1 = 1$ which means that C_1 is a simple cylinder. By [AN16, Lem. 2.11], the top of C_1 is not contained in the bottom of C_3 , thus it is contained in the bottom of C_4 . But this is already excluded by the previous claim. q.e.d.

Claim 3: *The bottom of C_4 contains at most two saddle connections.*

Proof. The hypothesis that no saddle connection in the top of C_4 is also contained in its bottom implies that the top of C_4 is contained in the bottom of C_3 . Claim 1 implies that at least one saddle connection in the top of C_1 (resp. C_2) is contained in the bottom of C_3 . Thus the bottom of C_3 contains at least four saddle connections (the top of C_4 and at least two other saddle connections). Recall that we have 8 saddle connections, and the bottom of C_1 (resp. C_2) contains one saddle connection. Hence the bottom of C_4 contains at most two saddle connections. q.e.d.

Claim 4: *The top of C_i , $i \in \{1, 2, 4\}$, consists of two saddle connections between two distinct simple zeros.*

Proof. If the top of either C_1, C_2 , or C_4 contains a single zero, then we have two horizontal saddle connections joining this zero to itself.

Since all the zeros are simple, there are no saddle connections from this zero to another one. But this contradicts the condition that the graph G consisting of the horizontal saddle connections that do not contain x_0 is connected. q.e.d.

Assume that the bottom of C_4 consists of two saddle connections. Since the top of either C_1 or C_2 cannot be contained in the bottom of C_4 , one saddle connection in the bottom of C_4 is contained in the top of C_1 and the other one is contained in the top of C_2 . From the same argument as above, we see that there are two distinct zeros in the bottom of C_4 . Therefore, there must be a zero that is contained in both top and bottom of C_4 . Note that this zero is contained in the tops of C_1, C_2 , and in the bottom of C_3 . By an angle count, one can easily see that the total angle at this zero is at least 5π , which is a contradiction since all of the zeros are simple. We can then conclude that the bottom of C_4 consists of a single saddle connection, which means that C_4 is semi-simple. The proof of the lemma is now complete. q.e.d.

Appendix B. Proof of Lemma 5.9

Lemma B.1. *Let M be a horizontally periodic translation surface satisfying Case 4.II) in a rank two affine manifold $\mathcal{M} \subset \mathcal{H}(2, 1^2) \cup \mathcal{H}(1^4)$. Assume that M is \mathcal{M} -cylindrically stable. Then C_3 and C_4 are \mathcal{M} -parallel.*

Proof. Since \mathcal{M} has rank two, both C_3 and C_4 cannot be free otherwise we would have a Lagrangian subspace of dimension three in $p(T_M^{\mathbb{R}}\mathcal{M})$. Hence, it suffices to consider the possibility that one of C_3 or C_4 is free. Without loss of generality, assume by contradiction that C_3 is free and C_4 is \mathcal{M} -parallel to $\{C_1, C_2\}$.

Let us first consider the case C_3 contains a simple cylinder D . Recall that C_3 can be viewed as one cylinder in a 2-cylinder decomposition of a genus two translation surface. Hence, there are at most two saddle connections that are contained in both top and bottom borders of C_3 . From this observation, it is not difficult to see that D is free.

Assume that the boundary of D contains two simple zeros, then we can collapse D to get a surface M' which is contained in a rank two affine submanifold \mathcal{M}' of either $\mathcal{H}(2, 2)$ or $\mathcal{H}(2, 1^2)$. Note that M' also has a cylinder decomposition satisfying Case 4.II) in the horizontal direction.

By assumption, we know that M' has an involution τ with four fixed points. By inspection, we see that if $M' \in \mathcal{H}(2, 1^2)$, then τ must fix C_3 and C_4 and exchange C_1 and C_2 . But this would imply that τ has at least five fixed points since the double zero must be fixed by τ and we have 4 regular fixed points in the interiors of C_3 and C_4 . So we have a contradiction in this case. If $M' \in \mathcal{H}(2, 2)$, then we have two possibilities, either τ fixes C_1, C_2 and exchanges C_3, C_4 , or τ fixes C_3, C_4

and exchanges C_1 and C_2 . In either case, we see that C_4 is not \mathcal{M}' -parallel to C_1, C_2 . Thus in any neighborhood of M' in \mathcal{M}' , we can find a surface M'_1 on which C_4 is not parallel to C_1, C_2 . By the isomorphism from [MW17] of the tangent space of \mathcal{M}' with a subspace of the tangent space of \mathcal{M} , we see that there exists in any neighborhood of M in \mathcal{M} a surface M_1 on which C_4 is not parallel to $\{C_1, C_2\}$, which means that C_4 is not \mathcal{M} -parallel to $\{C_1, C_2\}$.

Suppose now that the boundary of D contains a double zero, which means that $M \in \mathcal{H}(2, 1^2)$. The assumption means that C_3 is contained in a translation surface in the stratum $\mathcal{H}(2)$. Since there is only one cylinder diagram for 2-cylinder decompositions of surfaces in $\mathcal{H}(2)$, we see that one side of C_1 (resp. C_2) contains only one saddle connection, which means that C_1 and C_2 are semi-simple. Note also that in this case any vertical ray that crosses C_1 or C_2 must intersect C_3 .

Consider now C_4 . If \bar{C}_4 contains a simple cylinder, then we have a contradiction by [AN16, Lem. 2.12]. Thus in this case C_4 must be simple. Note that there is only one 4-cylinder diagram satisfying all of these conditions which is shown in Figure 20. By a similar argument as in [AN16, Lem. 6.17], we can twist $\{C_1, C_2, C_4\}$ and C_3 independently so that D is vertical, and there exists a vertical cylinder E crossing each of C_1, C_2, C_3 once. Since C_4 is \mathcal{M} -parallel to C_1 and C_2 , there must exist a vertical cylinder E' in the equivalence class of E that crosses C_4 . Let h_i be the height of C_i and n_i be the number of times that a core curve of E' crosses C_i . Note that we have $n_1 = n_2 = n_3 = n$, and $0 < n_4 \leq n$. By the Cylinder Proportion Lemma we have $P(E, C_3) = P(E', C_3)$, which implies

$$\frac{h_3}{h_1 + h_2 + h_3} = \frac{nh_3}{n(h_1 + h_2 + h_3) + n_4h_4} \Leftrightarrow n_4h_4 = 0.$$

But this is clearly impossible. Thus we also have a contradiction.

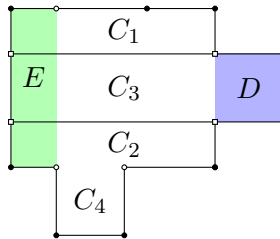

Figure 20. Cylinder decomposition in Case 4.II), $M \in \mathcal{H}(2, 1, 1)$, C_4 is simple.

It remains to consider the case C_3 is simple. One can twist C_3 so that it contains no vertical saddle connections and perform an extended cylinder collapse from [AN16, Proof. of Lem. 4.7] to get a new cylinder,

which we call C_3 by abuse of notation. This new cylinder contains a simple cylinder, so we are back to the previous case. The proof of the lemma is then complete. q.e.d.

Lemma B.2. *The cylinder C_3 contains a simple cylinder if and only if C_4 contains a simple cylinder.*⁴

Proof. Recall that C_3 (resp. C_4) either is simple, or contains a simple cylinder. Since C_3 (resp. C_4) is only adjacent to C_1 and C_2 , this lemma is an easy consequence of the Cylinder Proportion Lemma. q.e.d.

Lemma B.3. *Let k_3 (resp. k_4) be the number of saddle connections contained in both top and bottom of C_3 (resp. C_4). Then $k_3 = k_4$.*

Proof. Note that we have $0 \leq k_i \leq 2$, $i = 3, 4$, since C_3 (resp. C_4) can be viewed as a cylinder in a 2-cylinder decomposition of a translation surface of genus two. If $k_3 = 0$, then C_3 is simple, and by Lemma B.2, we know that C_4 is simple, hence $k_4 = 0$. Thus we can assume that k_3 and k_4 are both non-zero. Since the roles of C_3 and C_4 can be exchanged, we only need to consider the case $k_3 = 1$ and $k_4 = 2$.

Let us denote by σ_3 the unique saddle connection which is contained in both the top and bottom of C_3 . The two saddle connections contained in both the top and bottom of C_4 are denoted by σ_4 and σ'_4 . We can twist C_4 (and simultaneously C_3) such that there is a subdomain R of C_4 isometric to a rectangle whose top and bottom sides are the union of σ_4 and σ'_4 . Since \mathcal{M} is defined over \mathbb{Q} , we can assume that M is a square-tiled surface, which means that the vertical direction is periodic. There is a vertical cylinder D whose closure equals the closure of R . In particular, D is contained in $\overline{C_4}$.

Since C_3 and C_4 are \mathcal{M} -parallel, it follows that the closure of C_3 must contain a vertical cylinder D' which is \mathcal{M} -parallel to D . Note that D' must be a simple cylinder and σ_3 is entirely contained in D' .

We now remark that the equivalence class of D must be $\{D, D'\}$, since any other vertical cylinder must cross C_1 or C_2 . We can “stretch” simultaneously D and D' so that their heights are very small with respect to the lengths of the horizontal saddle connections outside of $D \cup D'$. Note that as the heights of D and D' tend to zero, the lengths of $\sigma_3, \sigma_4, \sigma'_4$ also decrease to zero.

Observe that we have a simple cylinder E that is contained in the closure of R consisting of simple closed geodesics crossing σ_4 once. As the height of D decreases to zero, the direction of E converges to the vertical direction. There must exist a cylinder E' that is \mathcal{M} -parallel to E which crosses C_3 . But as the direction of E is close to vertical, such a cylinder cannot be contained in the closure of C_3 . Hence, it must cross C_1 or C_2 from which we get a contradiction. q.e.d.

⁴The simple cylinders in this lemma need not be parallel, but a posteriori we will see that they are.

Proof of Lemma 5.9.

Proof. Lemma 5.9 follows from Lemmas B.1 and B.3. q.e.d.

Appendix C. 6-cylinder diagrams in genus three

In this section, we give the proof of Proposition 7.1.

The following lemma is well known to most of people in the field, we provide here a proof for the sake of completeness.

Lemma C.1. *Let M be a horizontally periodic translation surface in a stratum $\mathcal{H}(\kappa)$ of genus g , where $|\kappa| = n$. Denote by C_1, \dots, C_k the horizontal cylinders of M , and let γ_i be a core curve of C_i for $i = 1, \dots, k$. Then we have*

- (a) $k \leq g + n - 1$,
- (b) *If $k = g + n - 1$ then complement of the curves $\{\gamma_1, \dots, \gamma_k\}$ is the disjoint union of n punctured spheres, each of which contains a unique singularity of M . In particular, if $\kappa = (1, \dots, 1)$, and $k = 3g - 3$, then each of those components is the interior of a pair of pants (or a thrice-punctured sphere).*

Proof. Cut M along the curves $\gamma_1, \dots, \gamma_k$, we get m compact surfaces with boundary denoted by $\tilde{M}_1, \dots, \tilde{M}_m$. Since each \tilde{M}_j must contain a singularity of M , we have $m \leq n$. Let g_i and r_i be respectively the genus and the number of boundary components of \tilde{M}_j . Since we have

$$\chi(M) = \chi(\tilde{M}_1) + \dots + \chi(\tilde{M}_m),$$

it follows

$$2-2g = \sum_{j=1}^m (2-2g_j-r_j) \leq \sum_{j=1}^m (2-r_j) = 2m - \sum_{j=1}^m r_j = 2m-2k \leq 2n-2k.$$

Thus we have

$$k \leq g + n - 1.$$

The equality occurs if and only if $m = n$, and $g_j = 0$, for $j = 1, \dots, m$, which means that each \tilde{M}_j is a sphere with some discs removed and contains a unique singularity of M . If $\kappa = (1, \dots, 1)$, each \tilde{M}_j contains a cone point of angle 4π . The Gauss-Bonnet Theorem then implies that we must have $\chi(\tilde{M}_j) = -1$. q.e.d.

Proof of Proposition 7.1. Let $C_i, i = 1, \dots, 6$, denote the horizontal cylinders of M , and let γ_i be a core curve of C_i . By Lemma C.1, the family $\{\gamma_1, \dots, \gamma_6\}$ cuts M into 4 pairs of pants denoted by $\tilde{M}_1, \dots, \tilde{M}_4$. Let x_j be the unique singularity of M that is contained in \tilde{M}_j .

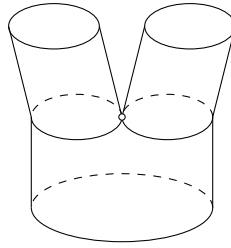

Figure 21. A component \tilde{M}_j .

Here below, we record some properties of the cylinders C_1, \dots, C_6 .

- (a) Each boundary component of C_i has at most 2 saddle connections, and contains a unique zero of M .
- (b) Each zero is contained in the boundary of 3 cylinders.
- (c) Each cylinder contains two distinct zeros in its boundary.

For $i = 1, \dots, 6$, let δ_i be a saddle connection in C_i connecting the pair of zeros in its boundary. The union $\cup_{i=1}^6 \delta_i$ is an embedded graph Γ in M . This graph is also the dual graph of the nodal curve obtained from M by pinching $\gamma_1, \dots, \gamma_6$. By definition, Γ has 4 vertices and 6 edges. There are 2 admissible configurations for Γ that are shown in Figure 22. In Case 1, any pair of vertices are connected by only one edge, in Case 2 there are two pairs of vertices such that there are two edges between the vertices in each pair. We will derive the possible cylinder diagrams from the configurations of Γ .

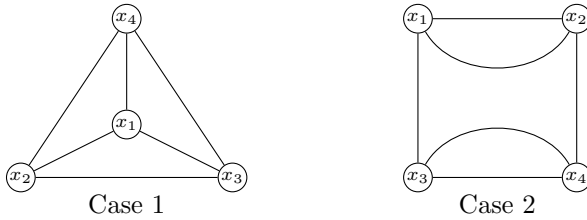

Figure 22. Configurations of the graph Γ .

Case 1: Let ℓ_i be the circumference of C_i , and assume that $\ell_1 = \max\{\ell_1, \dots, \ell_6\}$. We claim that each boundary component of C_1 contains two saddle connections. This is because otherwise C_1 is a semi-simple cylinder, and there would be another cylinder C_i such that $\ell_i > \ell_1$.

We can assume that the zeros of M in the top and bottom borders of C_1 are respectively x_1 and x_2 . We now remark that each saddle connection in the top border of C_1 is the bottom border of another cylinder. We can assume that the cylinders whose bottom border is contained in the top of C_1 are C_2 and C_3 . Similarly, there are two

cylinders C_i, C_j whose top border is contained in the bottom border of C_1 . We claim that $\{i, j\} \cap \{2, 3\} = \emptyset$ because otherwise there would be two edges in Γ between x_1 and x_2 . Thus we can assume that $\{i, j\} = \{4, 5\}$.

Note that by the same argument we see that the top borders of C_2 and C_3 contain two distinct zeros, which are neither x_1 nor x_2 . The same is true for the bottom borders of C_4 and C_5 . Thus we can assume that the top of C_2 and the bottom of C_4 contain the same zero x_3 . Consequently, the top of C_3 and the bottom of C_5 contain x_4 . Without loss of generality, we can suppose that $l_2 < l_4$, which means that C_2 is a simple cylinder, while C_4 is strictly semi-simple, and the bottom border of C_4 contains two saddle connections. Since we have $l_2 + l_3 = l_4 + l_5 = l_1$, it follows that $l_3 > l_5$. Hence C_5 is a simple cylinder, and the top of C_3 contains two saddle connections. From this we deduce that the cylinder C_6 must be simple, with top border contained in the bottom border of C_4 , and bottom border contained in the top border of C_3 . In conclusion, there is a unique cylinder diagram corresponding to this configuration of Γ . This cylinder diagram is depicted in Case 6.a of Figure 17 with a different labeling of the cylinders.

Case 2: We can assume that there are two edges between x_1 and x_2 and between x_3 and x_4 . Observe that in this case, there are two cylinder core curves that separate $\{x_1, x_2\}$ from $\{x_3, x_4\}$. In particular, they are homologous. Cutting M along those curves and permuting the gluings, we obtain two translation surfaces in $\mathcal{H}(1, 1)$, each of which admits a 3-cylinder decomposition in the horizontal direction. Therefore, one can recover the cylinder diagram of M from the unique 3-cylinder diagram for $\mathcal{H}(1, 1)$ and a choice of regluing. The possible diagrams are depicted by Cases 6.b, 6.c, and 6.d of Figure 17. q.e.d.

References

- [AN16] David Aulicino and Duc-Manh Nguyen. Rank two affine submanifolds in $\mathcal{H}(2, 2)$ and $\mathcal{H}(3, 1)$. *Geom. Topol.*, 20(5):2837–2904, 2016. MR3556350, Zbl 1370.32006.
- [ANW16] David Aulicino, Duc-Manh Nguyen, and Alex Wright. Classification of higher rank orbit closures in $\mathcal{H}^{\text{odd}}(4)$. *J. Eur. Math. Soc. (JEMS)*, 18(8):1855–1872, 2016. MR3518480, Zbl 1369.37044.
- [Api18] Paul Apisa. $\text{GL}_2\mathbb{R}$ orbit closures in hyperelliptic components of strata. *Duke Math. J.*, 167(4):679–742, 2018. MR3769676.
- [Aul15] David Aulicino. Affine manifolds and zero Lyapunov exponents in genus 3. *Geom. Funct. Anal.*, 25(5):1333–1370, 2015. MR3426056, Zbl 1357.37078.
- [EM18] Alex Eskin and Maryam Mirzakhani. Invariant and stationary measures for the $\text{SL}(2, \mathbb{R})$ action on moduli space. *Publ. Math. Inst. Hautes Études Sci.*, 127:95–324, 2018. MR 3814652, Zbl 06914160.

- [EMM15] Alex Eskin, Maryam Mirzakhani, and Amir Mohammadi. Isolation, equidistribution, and orbit closures for the $SL(2, \mathbb{R})$ action on moduli space. *Ann. of Math. (2)*, 182(2):673–721, 2015. MR3418528, Zbl 1357.37040.
- [Fil16] Simion Filip. Splitting mixed Hodge structures over affine invariant manifolds. *Ann. of Math. (2)*, 183(2):681–713, 2016. MR3450485, Zbl 1342.14015.
- [FM12] Benson Farb and Dan Margalit. *A primer on Mapping Class Groups*, volume 49 of *Princeton Mathematical Series*. Princeton University Press, 2012. Zbl 1245.57002.
- [For11] Giovanni Forni. A geometric criterion for the nonuniform hyperbolicity of the Kontsevich-Zorich cocycle. *J. Mod. Dyn.*, 5(2):355–395, 2011. With an appendix by Carlos Matheus. MR2820565 (2012f:37061), Zbl 1238.30031.
- [KZ03] Maxim Kontsevich and Anton Zorich. Connected components of the moduli spaces of Abelian differentials with prescribed singularities. *Invent. Math.*, 153(3):631–678, 2003. MR2000471 (2005b:32030), Zbl 1087.32010.
- [Lan08] Erwan Lanneau. Connected components of the strata of the moduli spaces of quadratic differentials. *Ann. Sci. Éc. Norm. Supér. (4)*, 41(1):1–56, 2008. MR2423309 (2009e:30094), Zbl 1161.30033.
- [LNW17] Erwan Lanneau, Duc-Manh Nguyen, and Alex Wright. Finiteness of Teichmüller curves in non-arithmetic rank 1 orbit closures. *Amer. J. Math.*, 139(6):1449–1463, 2017. MR3730926, Zbl 1382.32011.
- [McM06] Curtis T. McMullen. Prym varieties and Teichmüller curves. *Duke Math. J.*, 133(3):569–590, 2006. Zbl 1099.14018.
- [McM07] Curtis T. McMullen. Dynamics of $SL_2(\mathbb{R})$ over moduli space in genus two. *Ann. of Math. (2)*, 165(2):397–456, 2007. MR2299738 (2008k:32035), Zbl 1131.14027.
- [MMW17] Curtis T. McMullen, Ronen E. Mukamel, and Alex Wright. Cubic curves and totally geodesic subvarieties of moduli space. *Ann. of Math. (2)* 185(3):957–990, 2017. MR3664815, Zbl 06731862.
- [MW17] Maryam Mirzakhani and Alex Wright. The boundary of an affine invariant submanifold. *Invent. Math.*, 209(3):927–984, 2017. MR3681397, Zbl 1378.37069.
- [MW18] Maryam Mirzakhani and Alex Wright. Full-rank affine invariant submanifolds. *Duke Math. J.*, 167(1):1–40, 2018. MR3743698.
- [NW14] Duc-Manh Nguyen and Alex Wright. Non-Veech surfaces in $\mathcal{H}^{\text{hyp}}(4)$ are generic. *Geom. Funct. Anal.*, 24(4):1316–1335, 2014. MR3248487, Zbl 1303.30039.
- [SW04] John Smillie and Barak Weiss. Minimal sets for flows on moduli space. *Israel J. Math.*, 142:249–260, 2004. MR2085718 (2005g:37067), Zbl 1052.37025.
- [Wri14] Alex Wright. The field of definition of affine invariant submanifolds of the moduli space of abelian differentials. *Geom. Topol.*, 18(3):1323–1341, 2014. MR3254934, Zbl 1320.32019.
- [Wri15] Alex Wright. Cylinder deformations in orbit closures of translation surfaces. *Geom. Topol.*, 19(1):413–438, 2015. MR3318755, Zbl 1318.32021.

DEPARTMENT OF MATHEMATICS
BROOKLYN COLLEGE
2900 BEDFORD AVENUE
BROOKLYN, NY 11210-2889
USA

E-mail address: david.aulicino@brooklyn.cuny.edu

IMB BORDEAUX-CNRS UMR 5251
UNIVERSITY OF BORDEAUX
351, COURS DE LA LIBERATION
F33405 TALENCE
FRANCE

E-mail address: duc-manh.nguyen@math.u-bordeaux.fr