

A VERVAAT-LIKE PATH TRANSFORMATION FOR THE REFLECTED BROWNIAN BRIDGE CONDITIONED ON ITS LOCAL TIME AT 0

BY PHILIPPE CHASSAING AND SVANTE JANSON

Institut Elie Cartan and Uppsala University

We describe a Vervaat-like path transformation for the reflected Brownian bridge conditioned on its local time at 0: up to random shifts, this process equals the two processes constructed from a Brownian bridge and a Brownian excursion by adding a drift and then taking the excursions over the current minimum. As a consequence, these three processes have the same occupation measure, which is easily found.

The three processes arise as limits, in three different ways, of profiles associated to hashing with linear probing, or, equivalently, to parking functions.

1. Introduction. We regard the Brownian bridge $b(t)$ and the normalized (positive) Brownian excursion $e(t)$ as defined on the circle R/Z , or, equivalently, as defined on the whole real line, being periodic with period 1. We define, for $a \geq 0$, the operator Ψ_a on the set of bounded functions on the line by

$$(1.1) \quad \begin{aligned} \Psi_a f(t) &= f(t) - at - \inf_{-\infty < s \leq t} (f(s) - as) \\ &= \sup_{s \leq t} (f(t) - f(s) - a(t - s)). \end{aligned}$$

If f has period 1, then so has $\Psi_a f$; thus we may also regard Ψ_a as acting on functions on R/Z . Evidently, $\Psi_a f$ is nonnegative.

In this paper, we prove that, for every $a \geq 0$, the three following processes can be obtained (in law) from each other by random shifts, that we will describe explicitly:

- (i) X_a , which denotes the reflecting Brownian bridge $|b|$ conditioned to have local time at level 0 equal to a ;
- (ii) $Y_a = \Psi_a b$;
- (iii) $Z_a = \Psi_a e$.

We will find convenient to use the following formulas for Y_a and Z_a :

$$(1.2) \quad Y_a(t) = b(t) - at + \sup_{t-1 \leq s \leq t} (as - b(s)),$$

$$(1.3) \quad Z_a(t) = e(t) - at + \sup_{t-1 \leq s \leq t} (as - e(s)).$$

Received December 1999; revised March 2001.

AMS 2000 subject classifications. Primary 60J65; secondary 60C05, 68P10, 68R05.

Key words and phrases. Brownian bridge, Brownian excursion, local time, path transformation, profile, parking functions, hashing with linear probing.

For $t \in [0, 1]$, we also have

$$(1.4) \quad Z_a(t) = e(t) - at + \sup_{0 \leq s \leq t} (as - e(s)),$$

consistently with the notations of [13].

Given a stochastic process X and a positive number t , we let $L_t(X)$ denote the local time of the process X at level 0, on the interval $[0, t]$, defined as in [10], page 154, by:

$$L_t(X) = \lim_{\varepsilon \downarrow 0} \frac{1}{2\varepsilon} \int_0^t \mathbf{1}_{\{-\varepsilon < X_s < \varepsilon\}} ds;$$

with this convention, for example, b and $|b|$ have the same local time at 0, while, according to the usual convention ([28], Section I.2), the local time at 0 of $|b|$ is twice the local time at 0 of b . When possible, we extend $L(X)$ to $t \in (-\infty, 0)$, in such a way that $L_b(X) - L_a(X)$ is the local time of the process X at level 0, on the interval $[a, b]$, for any choice $-\infty < a < b < +\infty$.

The definition above of X_a is formally not precise enough, since it involves conditioning on an event of probability 0. However, there exists on $C[0, 1]$ a unique family of conditional distributions of $|b|$ (or b) given $L_1(b) = a$ which is weakly continuous in $a \geq 0$ ([25], Lemma 12]), and this can be taken as defining the distribution of X_a . The process X_a has been an object of interest in a number of recent papers in the domain of stochastic calculus: its distribution is described in [27], Section 6 by its decomposition in excursions. The sequence of lengths of excursions is computed in [7], using [24]. The local time process of X_a is described through an SDE in a recent paper [25] by Pitman, who in particular proves that, up to a suitable random time change, the local time process of X_a is a Bessel(3) bridge from a to 0 ([25], Lemma 14). (See also [4], where a Brownian bridge conditioned on its whole local time process is described.)

While X_a appears as a limit in the study of random forests [25], Z_a appears as a limit in the study of parking problems, or hashing (see [13]), an old but still hot topic in combinatorics and analysis of algorithms, these last years [1, 14, 17, 19, 26, 31, 32]. The fragmentation process of excursions of Z_a appears in the study of coalescence models [8, 9, 13], an emergent topic in probability theory and an old one in physical chemistry, astronomy and a number of other domains ([5], Section 1.4). See [5] for background and an extensive bibliography, and also [3, 6, 16] among others. As explained later, Y_a is tightly related to Z_a through a path transformation, due to Vervaat [33], connecting e and b .

REMARK 1.1. For $a = 0$, we have $X_0 \stackrel{\text{law}}{=} e$ ([25], Lemma 12) and, trivially, $Y_0 = b - \min b$ and $Z_0 = e$, and the identity, up to shift of these reduces to the result by Vervaat [33].

For a positive, the three processes X_a , Y_a and Z_a do not coincide without shifting. This can be seen by observing first that a.s. $Y_a(0) > 0$, while $X_a(0) = Z_a(0) = 0$, and secondly that Z_a a.s. has an excursion beginning at 0, that is,

$\inf\{t > 0 : Z_a(t) = 0\} > 0$ (see [8], where the distribution of this excursion length is found), while this is false for X_a (as a consequence of [27], Section 6). It also follows that Z_a is not invariant under time reversal (while X_a and Y_a are).

We mention two further constructions of the processes above. First, let B be a standard one-dimensional Brownian motion started at 0, and define

$$\tau_t = \inf\{s \geq 0 : L_s(B) = t\}.$$

Then X_a can also be seen as the reflected Brownian motion $|B|$ conditioned on $\tau_a = 1$; see, for example, [25], the lines following (11) or [27], identity (5.a).

Secondly, define $\tilde{b}(t) = b(t) - \int_0^1 b(s) ds$. It is easily verified that \tilde{b} is a stationary Gaussian process (on R/Z or on R), for example, by calculating its covariance function

$$\text{Cov}(\tilde{b}(s), \tilde{b}(t)) = \frac{1 - 6|s - t|(1 - |s - t|)}{12}, \quad |s - t| \leq 1.$$

Since b and \tilde{b} differ only by a (random) constant, $Y_a = \Psi_a(\tilde{b})$ too. This implies that Y_a is a stationary process. (X_a and Z_a are not, again because they vanish at 0.)

We may similarly define $\tilde{e}(t) = e(t) - \int_0^1 e(s) ds$, and obtain $Z_a = \Psi_a(\tilde{e})$, but we do not know any interesting consequences of this.

Precise statements of the relations between the three processes X_a , Y_a and Z_a are given in Section 2. The three processes arise as limits, under three different conditions, of profiles associated with parking schemes (also known as hashing with linear probing). This is described in Sections 3 and 4. The proofs are given in the remaining sections.

2. Main results. In this section we give precise descriptions of the shifts connecting the three processes X_a , Y_a and Z_a , in all six possible directions. Let $a \geq 0$ be fixed.

First, assume that the Brownian bridge b is built from e using Vervaat’s path transformation [10, 11, 33]: given a uniform random variable U , independent of e ,

$$(2.1) \quad b(t) = e(U + t) - e(U).$$

Then

$$\Psi_a b(t) = \Psi_a e(U + t),$$

so that:

THEOREM 2.1. *For U uniform and independent of Z_a ,*

$$Z_a(U + \cdot) \stackrel{\text{law}}{=} Y_a.$$

As a consequence, Y_a is a stationary process on the line, or on the circle R/Z , as was seen above in another way. A far less obvious result is:

THEOREM 2.2. For U uniform on $[0, 1]$ and independent of X_a ,

$$X_a(U + \cdot) \stackrel{\text{law}}{=} Y_a.$$

The proof will be given later. The case $a = 0$ of Theorem 2.2 is just Vervaat's path transformation, since, as remarked above, $X_0 \stackrel{\text{law}}{=} e$. In [10], one can find a host of similar path transformations connecting the Brownian bridge, excursion and meander.

COROLLARY 2.3. The occupation measures of X_a , Y_a and Z_a coincide, and have the distribution function

$$1 - e^{-2ax - 2x^2}.$$

This is also the distribution function of $Y_a(t)$ for any fixed t .

Recall that a random variable W is Rayleigh distributed if $\Pr(W \geq x) = e^{-x^2/2}$. The occupation measure of X_a (or Y_a , Z_a) is then the law of half the residual life at time a of W : $\Pr((W - a)/2 \geq x \mid W \geq a) = e^{-2ax - 2x^2}$. For $a = 0$ we recover the Durrett-Iglehart result for the occupation measure of the Brownian excursion: it is the law of $W/2$ [15].

PROOF OF COROLLARY 2.3. By definition, the occupation measure of X_a is the law of $X_a(U)$, so, from Theorem 2.2, it is also the law of $Y_a(0)$. The same is true for Z_a by Theorem 2.1, and for Y_a because it is stationary. We have

$$\begin{aligned} Y_a(0) &= \sup_{-1 \leq s \leq 0} (as - b(s)) \\ &\stackrel{\text{law}}{=} \sup_{0 \leq t \leq 1} (b(t) - at) \\ &\stackrel{\text{law}}{=} \sup_{0 \leq t \leq 1} ((1-t)B_{\frac{t}{1-t}} - at) \\ &= \sup_{0 \leq u \leq +\infty} \left(\frac{B_u - au}{1+u} \right). \end{aligned}$$

For positive numbers λ and μ , set

$$T_{\lambda, \mu} = \inf\{u \geq 0; B_u \geq \lambda u + \mu\}.$$

Using the exponential martingale $\exp(2\lambda B_u - 2\lambda^2 u)$, it is easy to derive that

$$\Pr(T_{\lambda, \mu} < +\infty) = e^{-2\lambda\mu},$$

see [28], Exercise II.3.12. We have thus:

$$\begin{aligned} \Pr(Y_a(0) \geq x) &= \Pr\left(\exists u \geq 0 \text{ such that } \frac{B_u - au}{1+u} \geq x\right) \\ &= \Pr(T_{a+x, x} < +\infty) \\ &= e^{-2ax - 2x^2}. \end{aligned}$$

□

PROBLEM 2.4. *What are the laws of $X_a(t)$ and $Z_a(t)$ (which depend on t)?*

We need an additional notation to define a random shift from Y_a or Z_a to X_a : let $T(X)$ denote the inverse process of $L(X)$.

THEOREM 2.5. *Suppose $a > 0$. Let U be uniformly distributed on $[0, 1]$ and independent of Z_a or Y_a . Set*

$$\begin{aligned} \tau &= T_{aU}(Z_a), \\ \tilde{\tau} &= T_{aU}(Y_a). \end{aligned}$$

We have

$$\begin{aligned} X_a &\stackrel{\text{law}}{=} Z_a(\tau + \cdot) \\ &\stackrel{\text{law}}{=} Y_a(\tilde{\tau} + \cdot). \end{aligned}$$

Note that as a difference with Theorems 2.1 and 2.2, here τ (resp. $\tilde{\tau}$) depends on Z_a (resp. Y_a).

Thus we obtain X_a by shifting any of the processes uniformly in local time, while we have seen above that we obtain Y_a by shifting uniformly in real time.

THEOREM 2.6. *Suppose $a > 0$.*

(i) *Almost surely, $t \mapsto L_t(X_a) - at$ reaches its maximum at a unique point V in $[0, 1)$ and*

$$X_a(V + \cdot) \stackrel{\text{law}}{=} Z_a.$$

(ii) *Almost surely, $t \mapsto L_t(Y_a) - at$ reaches its maximum at a unique point \tilde{V} in $[0, 1)$ and*

$$Y_a(\tilde{V} + \cdot) \stackrel{\text{law}}{=} Z_a.$$

Moreover, \tilde{V} is uniform on $[0, 1]$ and independent of $Y_a(\tilde{V} + \cdot)$.

In contrast, and as an explanation, $t \mapsto L_t(Z_a) - at$ reaches its maximum at 0; see the proof in Section 11. It is easily verified that V is *not* uniformly distributed.

REMARK 2.7. For $a = 0$, Theorems 2.5 and 2.6 hold if we instead define $\tau = 0$, $V = 0$ and $\tilde{\tau} = \tilde{V}$ as the unique points where Z_0 , X_0 and Y_0 , respectively, attain their minimum value 0; see Remark 1.1.

Finally, we observe that it is possible to invert Ψ_a and recover the Brownian bridge b from $Y_a = \Psi_a b$ and the excursion e from $Z_a = \Psi_a e$ using local times.

THEOREM 2.8. *For any t ,*

$$b(t) = Y_a(t) - Y_a(0) - L_t(Y_a) + at$$

and

$$e(t) = Z_a(t) - L_t(Z_a) + at.$$

Combining Theorems 2.6 and 2.8, we can construct Brownian excursions from X_a and Y_a too.

COROLLARY 2.9. *Let V and \tilde{V} be as in Theorem 2.6. Then*

$$e'(t) = X_a(V + t) + at - L_{V+t}(X_a) + L_V(X_a)$$

and

$$e''(t) = Y_a(\tilde{V} + t) + at - L_{\tilde{V}+t}(Y_a) + L_{\tilde{V}}(Y_a),$$

respectively, define normalized Brownian excursions.

In the case of Y_a , in addition, e'' and \tilde{V} are independent.

The problem of possible other shifts is addressed in the concluding remarks.

3. Parking schemes and associated spaces. A parking scheme ω describes how m cars c_1, c_2, \dots, c_m park on n places $\{1, 2, \dots, n\}$. We write

$$\omega = (\omega_k)_{1 \leq k \leq m},$$

where each $\omega_k \in \{1, \dots, n\}$. According to ω , car c_1 parks on place ω_1 . Then car c_2 parks on place ω_2 if ω_2 is still empty, else it tries $\omega_2 + 1, \omega_2 + 2, \dots$, until it finds an empty place, and so on. We adopt the convention that $n + 1 = 1$, and more generally $n + k = k$. We consider only the case $1 \leq m < n$.

The interest of combinatorists in parking schemes was born from a paper by Konheim and Weiss [21], in 1966, about hashing with linear probing, a popular search method, that had also been studied, notably, by Don Knuth, in 1962 (see the historical notes in his 1999 paper [19], or pages 526–539 in his book [18]). The metaphor of parking was already used by Konheim and Weiss. The two recent and beautiful papers by Flajolet, Poblete and Viola [17] and Knuth [19] drew the attention of the authors to the connection between parking schemes and Brownian motion (see also [13, 14]). For a similar connection between trees and Brownian motion, see [2, 6, 25, 30], among others.

Let $P_{n,m}$ denote the set of all parking schemes of m cars on n places, and let $CP_{n,m}$ denote the subset of *confined* parking schemes, *confined* meaning that the last place is assumed to be left empty. We have

$$\#P_{n,m} = n^m \text{ and } \#CP_{n,m} = n^{m-1}(n - m);$$

the last can be seen as follows. For $\omega \in P_{n,m}$, we define the shift (rotation)

$$r\omega = (-1 + \omega_k)_{1 \leq k \leq m},$$

moving all cars back one place (modulo n); the action of r on $P_{n,m}$ draws n^{m-1} orbits of n elements, each of them containing $n - m$ elements of $CP_{n,m}$.

Let $Y_k(\omega)$ be the number of cars whose first try is on place k , according to $\omega \in P_{n,m}$. For any natural integer k , set

$$S_{k+1}(\omega) = S_k(\omega) + Y_{k+1}(\omega),$$

with $S_0(\omega) = 0$. Our convention extends to $Y_{k+n} = Y_k$, so that $S_{k+n} = S_k + m$. Set:

$$(3.1) \quad W(\omega, i) = S_i(\omega) - i \frac{m}{n},$$

and note that $W(\omega, k + n) = W(\omega, k)$. We have

PROPOSITION 3.1. *There exists at least an element of $CP_{n,m}$, $x(\kappa)$, in each orbit κ , such that $W(x(\kappa), \cdot)$ is nonnegative.*

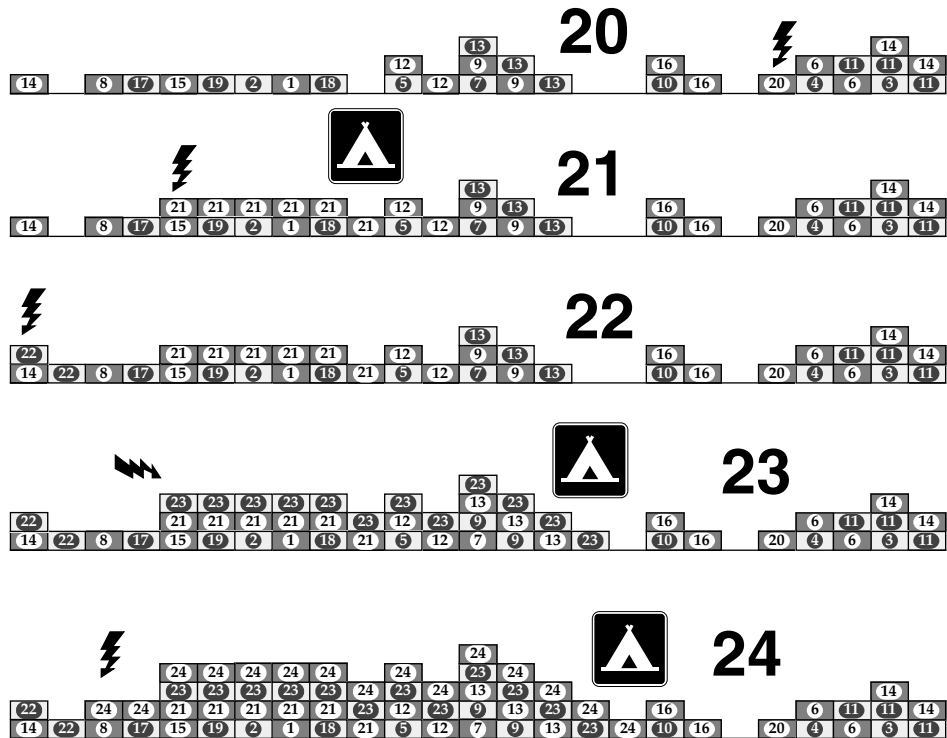

FIG. 1. Elements of $P_{25,m}$, $m = 20, \dots, 24$.

PROOF. Let ω denote an element of $P_{n,m}$. Since $S(r^j \omega, k) = S(\omega, k + j) - S(\omega, j)$ and thus $W(r^j \omega, k) = W(\omega, k + j) - W(\omega, j)$, $W(r^j \omega, \cdot)$ is nonnegative if and only if $W(\omega, j) = \min_k W(\omega, k)$. This proves that $x(\kappa) = r^j \omega$ exists in $P_{n,m}$. We postpone the proof that in fact $r^j \omega \in CP_{n,m}$ to Proposition 5.4 (see also [13]). \square

In general, in the same orbit κ , there are several elements z such that $W(z, \cdot)$ is nonnegative: we let $x(\kappa)$ be one particular choice, and let $E_{n,m}$ be the set of the n^{m-1} elements $x(\kappa)$. (This set is thus to some extent arbitrary, but the results below hold for any choice.)

4. Convergence results. For ω in $P_{n,m}$, let $H_k(\omega)$ denote the number of cars that try, successfully or not, to park on place k . (We regard H_k as defined for all integers k , with $H_{k+n} = H_k$.) We rescale H_k and define $h_n(k/n, \omega) = H_k(\omega)/\sqrt{n}$; h_n is then extended, by linear interpolation, to a continuous periodic function on R :

$$h_n(t, \omega) = \frac{(1 + \lfloor nt \rfloor - nt)H_{\lfloor nt \rfloor}(\omega) + (nt - \lfloor nt \rfloor)H_{1+\lfloor nt \rfloor}(\omega)}{\sqrt{n}}.$$

that we call the *profile* of ω . Let $\mu_{n,\ell}$ (resp. $\tilde{\mu}_{n,\ell}, \hat{\mu}_{n,\ell}$) denote the law of $(h_n(t))_{0 \leq t \leq 1}$ when ω is drawn at random in $P_{n,n-\ell}$ (resp. $CP_{n,n-\ell}, E_{n,n-\ell}$).

Central to our results are the following theorems:

THEOREM 4.1. *If $\ell/\sqrt{n} \rightarrow a \geq 0$, then*

$$\mu_{n,\ell} \xrightarrow{\text{weakly}} Y_a.$$

THEOREM 4.2. *If $\ell/\sqrt{n} \rightarrow a \geq 0$, then*

$$\tilde{\mu}_{n,\ell} \xrightarrow{\text{weakly}} X_a.$$

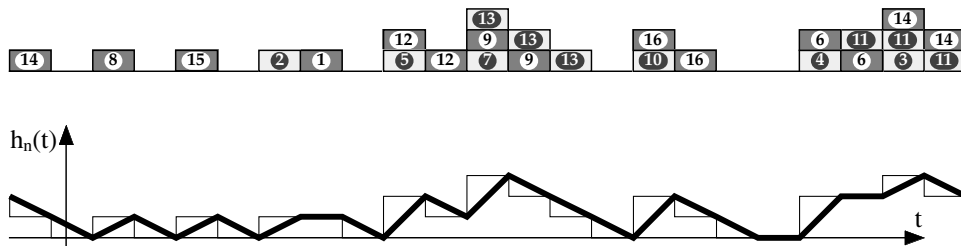

FIG. 2. Profile.

THEOREM 4.3. *If $\ell/\sqrt{n} \rightarrow a \geq 0$, then*

$$\hat{\mu}_{n,\ell} \xrightarrow{\text{weakly}} Z_a.$$

Theorem 4.3 was also proved, by similar methods, in [13], Theorem 3.1 and Lemma 3.7.

As will be seen in detail later, Theorems 2.1 and 2.2 can be seen as consequences of the preceding convergence results, combined with the evident relation

$$h_n(t, r^j \omega) = h_n\left(t + \frac{j}{n}, \omega\right)$$

and with the following obvious statement: the random rotation of a random element of $CP_{n,m}$ or of $E_{n,m}$ gives a random element of $P_{n,m}$. More formally:

PROPOSITION 4.4. *If ω is random uniform on $P_{n,m}$, $CP_{n,m}$ or on $E_{n,m}$, and U is uniform on $[0, 1]$ and independent of ω , then $r^{\lfloor nU \rfloor} \omega$ is random uniform on $P_{n,m}$.*

A different kind of random rotation gives Theorem 2.5: let ω be random in $P_{n,m}$ or in $E_{n,m}$ and choose randomly an empty place j of ω . Then $r^j \omega$ is random in $CP_{n,m}$. More formally, let us define an operator R from $P_{n,m}$ to $CP_{n,m}$ as shifting to the next empty place:

$$R\omega = r^j \omega,$$

where $j \geq 1$ is the first place left empty by ω . Thus $R^{\lfloor (n-m)U \rfloor} \omega$ (with U random uniform) is a rotation of ω to a random empty place, that is, to a random element of the corresponding orbit in $CP_{n,m}$, and we have:

PROPOSITION 4.5. *If ω is random uniform on $P_{n,m}$, $CP_{n,m}$ or on $E_{n,m}$, and U is uniform on $[0, 1]$ and independent of ω , then $R^{\lfloor (n-m)U \rfloor} \omega$ is random uniform on $CP_{n,m}$.*

For Theorem 2.5 we use also the convergence of the number of empty places in a given interval of $\{1, 2, \dots, n\}$ to the local time of X_a, Y_a or Z_a in the corresponding interval of $[0, 1]$.

More precisely, let $V_{j,k}(\omega)$ denote the number of empty places in the set $\{j+1, j+2, \dots, k\}$, according to the parking scheme ω , and define, in analogy with h_n above, a corresponding continuous function v_n on $[0, 1]$ by rescaling and linear interpolation so that $v_n(k/n) = V_{0,k}/\sqrt{n}$ for integers k , that is,

$$v_n(t, \omega) = \frac{(1 + \lfloor nt \rfloor - nt)V_{0,\lfloor nt \rfloor}(\omega) + (nt - \lfloor nt \rfloor)V_{0,1+\lfloor nt \rfloor}(\omega)}{\sqrt{n}}, \quad 0 \leq t \leq 1.$$

We then have the following extension of Theorems 4.1–4.3, yielding joint convergence of the processes h_n and v_n .

THEOREM 4.6. *Suppose $\ell/\sqrt{n} \rightarrow a \geq 0$. On $[0, 1]$, the following hold:*

(i) *If ω is drawn at random in $P_{n,n-\ell}$, then*

$$(h_n(\cdot, \omega), v_n(\cdot, \omega)) \xrightarrow{\text{weakly}} (Y_a, L(Y_a)).$$

(ii) *If ω is drawn at random in $CP_{n,n-\ell}$, then*

$$(h_n(\cdot, \omega), v_n(\cdot, \omega)) \xrightarrow{\text{weakly}} (X_a, L(X_a)).$$

(iii) *If ω is drawn at random in $E_{n,n-\ell}$, then*

$$(h_n(\cdot, \omega), v_n(\cdot, \omega)) \xrightarrow{\text{weakly}} (Z_a, L(Z_a)).$$

5. Results on parking schemes. Consider a fixed $\omega \in P_{n,m}$. As remarked above, we regard the functions $Y_k, S_k, W(\omega, k)$ and H_k as defined for all integers k ; $S_{k+n} = S_k + m$ and the three others have period n .

Note that, among the cars that visit place k , only one will not visit place $k + 1$, so:

PROPOSITION 5.1.

$$H_{k+1} = (H_k - 1)_+ + Y_{k+1}.$$

This recursion does not define fully H_k , given $(Y_k)_{0 \leq k \leq n}$, as the recursion starts nowhere. In order to circumvent this difficulty, we have to find a place left empty by ω . Let

$$(5.1) \quad \Delta_k = \max_{i \leq k} (i - S_i) = \max_{-n+k < i \leq k} (i - S_i).$$

PROPOSITION 5.2. *For a given ω and place k , there are two cases:*

- (i) *k is left empty, $H_k = 0$, $k - S_k = \Delta_{k-1} + 1$ and $\Delta_k = \Delta_{k-1} + 1$.*
- (ii) *k is occupied, $H_k \geq 1$, $k - S_k \leq \Delta_{k-1}$ and $\Delta_k = \Delta_{k-1}$.*

PROOF. Clearly k is left empty if and only if $H_k = 0$.

Next, observe that if $S_k - S_j \geq k - j$ for some $j < k$, then at least $k - j$ cars have tried to park after j , and there is not room enough for all of them to park on $\{j + 1, \dots, k - 1\}$, so one of them will park on k . Conversely, suppose that some car parks on k , and let j be the last empty place before k . Then the $k - j$ places $\{j + 1, \dots, k\}$ are all occupied, and the cars on them must all have made their first try in the same set, so $S_k - S_j \geq k - j$.

Consequently, k is empty if and only if $S_k - S_j < k - j$ for all $j < k$, which is equivalent to $k - S_k > \max_{j < k} (j - S_j) = \Delta_{k-1}$ and thus also to $\Delta_k > \Delta_{k-1}$.

Finally, note that always $k - S_k \leq k - S_{k-1} \leq 1 + \Delta_{k-1}$, and thus $\Delta_{k-1} \leq \Delta_k \leq \Delta_{k-1} + 1$. \square

This leads to an explicit formula for H_k , given Y_k .

PROPOSITION 5.3. *For any integer k ,*

$$H_k = 1 + S_k - k + \Delta_{k-1}.$$

PROOF. First observe that by Proposition 5.2, both sides vanish if k is empty. We then proceed by induction, beginning at any empty place (both sides have period n). Going from k to $k + 1$, if k is occupied, then the left hand side increases by Proposition 5.1 by $H_{k+1} - H_k = Y_{k+1} - 1$ while the right hand side increases by $Y_{k+1} - 1 + \Delta_k - \Delta_{k-1}$, which by Proposition 5.2 equals $Y_{k+1} - 1$ too. Similarly, if k is empty, then both sides increase by Y_{k+1} . Hence the equality holds for every k . \square

We can also now complete the proof of Proposition 3.1.

PROPOSITION 5.4. *If $W(\omega, i) = \min_k W(\omega, k)$, then place i is empty.*

PROOF. For every $k < i$,

$$S_i - S_k = W(\omega, i) - W(\omega, k) + (i - k)\frac{m}{n} \leq (i - k)\frac{m}{n} < i - k,$$

thus $i - S_i > \max_{k < i} (k - S_k) = \Delta_{i-1}$, and the result then follows by Proposition 5.2. \square

Recall that $V_{j,k}(\omega)$ denote the number of empty places in the set $\{j + 1, j + 2, \dots, k\}$, according to the parking scheme ω . As another immediate consequence of Proposition 5.2 we obtain:

PROPOSITION 5.5. *For $j \leq k$,*

$$V_{j,k} = \Delta_k - \Delta_j.$$

Further similar results are given in [13], Section 3.1.

We end this section with a discrete analog of Theorem 2.6, which would lead to a proof of Theorem 2.6 through the convergence theorems of Section 4. The proof of Theorem 2.6 that we give is however more direct, and we will not use this result in the sequel.

For ω in $P_{n,m}$, and $k \geq 0$, let $C(\omega, k)$ be defined by

$$C(\omega, k) = \frac{k(n - m)}{n} - V_{0,k}(\omega).$$

Clearly $C(\omega, k + n) = C(\omega, k)$, and we may use this to extend the definition to all integers k .

PROPOSITION 5.6. *For ω in $P_{n,m}$, assertions $C(\omega, i) = \min_\ell C(\omega, \ell)$ and $W(\omega, i) = \min_\ell W(\omega, \ell)$ are equivalent. For ω in $E_{n,m}$, $C(\omega, \cdot)$ is nonnegative.*

PROOF. According to Proposition 5.4, $W(\omega, i) = \min_{\ell} W(\omega, \ell)$ insures that place i is empty. The first assertion also insures that place i is empty, since it implies $C(\omega, i - 1) \geq C(\omega, i)$ and thus $V_{0,i} > V_{0,i-1}$.

As a simple consequence of Propositions 5.2 and 5.5, see also [13], for an empty place j and for $k \geq j$, we have

$$\begin{aligned} V_{j,k} &= \max_{j \leq \ell \leq k} (\ell - S_{\ell}) - j + S_j \\ &= \max_{j \leq \ell \leq k} \left(W(\omega, j) - W(\omega, \ell) + (\ell - j) \frac{n - m}{n} \right). \end{aligned}$$

Thus, for $k \geq j$,

$$\begin{aligned} C(\omega, k) - C(\omega, j) &= \frac{(k - j)(n - m)}{n} - V_{j,k} \\ &= \min_{j \leq \ell \leq k} \left(\frac{(k - \ell)(n - m)}{n} + W(\omega, \ell) - W(\omega, j) \right) \\ &\leq \omega(\omega, k) - W(\omega, j). \end{aligned}$$

By periodicity, the inequality persists for all integers k . This shows first that if j is a minimum point for C , the right hand side is nonnegative for all k , and j is a minimum point for W too. Moreover, if k is a minimum point for W , then for any empty place j , including any minimum point for C , $C(\omega, k) \leq C(\omega, j)$, thus k is a minimum point for C too.

The final assertion follows because $C(\omega, 0) = 0$, and if $\omega \in E_{n,m}$, then 0 is a minimum point for W , and thus also for C . \square

6. Convergence results: Proofs.

6.1. *Proof of Theorem 4.1.* Let $U^{(m)} = (U_k^{(m)})_{1 \leq k \leq m}$ denote a sequence of m independent random variables, uniform on $[0, 1]$. For $m \leq n$, the sequence $U^{(m)}$ generates the parking scheme $\omega^{(m)} \in P_{n,m}$ defined by

$$\omega_k^{(m)} = \lceil nU_k^{(m)} \rceil.$$

The n^m possible parking schemes generated this way are clearly equiprobable.

Consider the empirical process $\alpha_m(t)$ associated with $U^{(m)}$, defined on $[0, 1]$ by

$$(6.1) \quad \alpha_m(t) = m^{-1/2} \left(\#\{k : U_k^{(m)} \leq t\} - mt \right).$$

As $m \rightarrow \infty$, the processes α_m converge in distribution, as random elements of the space $D[0, 1]$, to a Brownian bridge ([12], Theorem 16.4). Due to the Skorohod representation theorem (see, e.g., [29], II.86.1), we may thus assume that the variables $U^{(m)}$ are such that, almost surely, as $m \rightarrow \infty$,

$$(6.2) \quad \alpha_m(t) \rightarrow b(t) \quad \text{uniformly on } [0, 1].$$

We have $m = n - \ell = n - a_n \sqrt{m}$, where $a_n \rightarrow a$. Then, by (3.1), for any integer j (extending α_m periodically),

$$(6.3) \quad W(\omega^{(m)}, j) = \sqrt{m} \alpha_m \left(\frac{j}{n} \right),$$

$$(6.4) \quad S_j - j = \sqrt{m} \left(\alpha_m \left(\frac{j}{n} \right) - a_n \frac{j}{n} \right).$$

Hence, as $n \rightarrow \infty$ and thus $m \rightarrow \infty$ too,

$$\frac{1}{\sqrt{n}} (S_{\lfloor nt \rfloor} - \lfloor nt \rfloor) \rightarrow b(t) - at,$$

uniformly on $[-1, 1]$, say. By (5.1), this implies

$$(6.5) \quad \frac{1}{\sqrt{n}} \Delta_{\lfloor nt \rfloor} \rightarrow \sup_{t-1 \leq s \leq t} (as - b(s)) = \sup_{s \leq t} (as - b(s)),$$

uniformly on $[0, 1]$, and thus by Proposition 5.3 and (1.2) we obtain

$$\frac{1}{\sqrt{n}} H_{\lfloor nt \rfloor}(\omega^{(m)}) \rightarrow b(t) - at + \sup_{s \leq t} (as - b(s)) = Y_a(t),$$

uniformly for all real t (by periodicity), which implies that:

PROPOSITION 6.1. *With the assumptions above, there is almost surely uniform convergence of $h_n(\cdot, \omega^{(m)})$ to $Y_a(\cdot)$.*

6.2. Proof of Theorem 4.3. We draw a random element $\omega^{(m)}$ in $P_{n,m}$ using $U^{(m)}$, as in Section 6.1. Let $p(\omega^{(m)}) = r^J \omega^{(m)}$ be its projection in $E_{n,m}$. Thus J is one of the points where $W(\omega^{(m)}, \cdot)$ attains its minimum, and by (6.1) and (6.3), it follows that α_m almost attains its minimum at J/n ; more precisely,

$$(6.6) \quad \alpha_m(J/n) = \inf_k \alpha_m(k/n) < \inf_t \alpha_m(t) + m^{-1/2}.$$

We can always assume that $1 \leq J \leq n$.

Moreover, we may assume that b is constructed from a Brownian excursion e by Vervaat's relation (2.1). This entails that b has almost surely a unique minimum in $[0, 1]$ at the point $1 - U$. Still assuming $m = n - \ell = n - a_n \sqrt{m}$, the uniform convergence (6.2) of $\alpha_m(t)$ to $b(t)$ and (6.6) imply that

$$(6.7) \quad \lim_{n \rightarrow \infty} \frac{J}{n} = 1 - U.$$

Since $H_k(p(\omega^{(m)})) = H_{k+J}(\omega^{(m)})$ and thus $h_n(t, p(\omega^{(m)})) = h_n(t + J/n, \omega^{(m)})$, which by Proposition 6.1 and (6.7) converges uniformly to $\Psi_a b(t + 1 - U) = \Psi_a e(t)$, we have:

PROPOSITION 6.2. *With the assumptions above, there is almost surely uniform convergence of $h_n(\cdot, p(\omega^{(m)}))$ to $Z_a(\cdot)$.*

See Sections 3.1 and 3.2 of [13] for more details.

6.3. *Proof of Theorem 4.2.* The sequence $S_j - j$ may be seen as a certain random walk (with fixed endpoint $S_n - n = m - n$). Considering only confined parking sequences means conditioning the random walk $S_j - j$ on ending at a minimum at $S_n - n$. This random walk should, after rescaling, converge to a Brownian bridge $b(t) - at$ from 0 to $-a$, conditioned on its minimum being $-a$, or, equivalently, a Brownian motion $B(t)$ conditioned on $B(1) = M(1) = -a$, with $M(t) = \min_{s \leq t} B(s)$; the corresponding process h_n would then, through Proposition 5.3, converge to $B - M$ with the same condition. By Lévy ([28], Theorem VI.2.3), $(B - M, -M)$ equals (in law) $(|B|, L)$, so this is the same as $|B(t)|$ conditioned on $B(1) = 0, L(1) = a$, or, equivalently, $|b(t)|$ conditioned on $L(1) = a$.

However we have not been able to make such an argument rigorous, and we rather proceed as in [6], Section 5: we use the fact that the sequence of excursion lengths of X_a is the weak limit of the sequence of block lengths, suitably normalized, in a random confined parking scheme of $CP_{n,n-\ell}$. Then we take advantage of the fact that the excursions of X_a appear in random order, independently of their shape and length, as explained in [27], Section 6, while the blocks of a random confined parking scheme have the same property. This allows us to build on the same space a sequence of random variables $g_n = (g_n(t))_{0 \leq t \leq 1}$, distributed according to $\tilde{\mu}_{n,\ell}$, and a random variable $X = (X(t))_{0 \leq t \leq 1}$, with the same distribution as X_a , in such a way that we can prove $g_n \rightarrow X$.

Sizes of blocks and lengths of excursions. For $y \in P_{n,m}$, let us define $R(y) = (R^{(k)}(y))_{k \geq 1}$ as the sequence of block lengths when the blocks are sorted by increasing date of birth [in increasing order of first arrival of a car: for instance, on the next figure, for $n = 25$ and $m = 16$, $R(y) = (2, 5, 5, 1, 2, 1, 0, \dots)$].

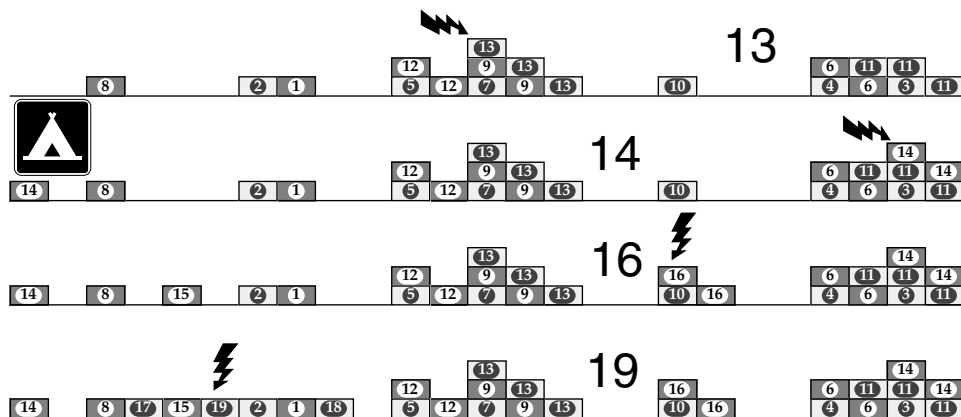

FIG. 3. Elements of $P_{25,m}$, $m = 13, \dots, 19$.

Let δ_n denote the law of $R(y)/n$ when y is drawn at random in $P_{n,n-\ell}$ or in $CP_{n,n-\ell}$. Theorems 1.5 and 1.6 of [13] assert that, assuming $\ell/\sqrt{n} \rightarrow a$,

$$\delta_n \xrightarrow{\text{weakly}} \mathcal{J}^* = (\mathcal{J}_k^*)_{k \geq 1},$$

in which \mathcal{J}^* is defined, for $k \geq 1$, given a sequence of independent standard Gaussian distributed random variables $(N_k)_{k \geq 1}$, by

$$(6.8) \quad \mathcal{J}_1^* + \mathcal{J}_2^* + \dots + \mathcal{J}_k^* = \frac{N_1^2 + N_2^2 + \dots + N_k^2}{a^2 + N_1^2 + N_2^2 + \dots + N_k^2}.$$

Assume $a > 0$ and let $\tau_a = T_a(B)$, where B is the standard linear Brownian motion started at 0. It is well known that $(\tau_t)_{t \geq 0}$ is a stable subordinator with index 1/2, meaning that, for any k and any k -tuple of positive numbers $(t_i)_{1 \leq i \leq k}$:

$$(\tau_{t_1+t_2+\dots+t_i})_{1 \leq i \leq k} \stackrel{\text{law}}{=} \left(\frac{t_1^2}{N_1^2} + \frac{t_2^2}{N_2^2} + \dots + \frac{t_i^2}{N_i^2} \right)_{1 \leq i \leq k}.$$

Setting $\tilde{\tau}_t = \tau_{at}/a^2$, an immediate consequence is

$$(\tilde{\tau}_t)_{t \geq 0} \stackrel{\text{law}}{=} (\tau_t)_{t \geq 0}.$$

It is also well known that $(\tau_t)_{t \geq 0}$ is a pure jump process, whose jump-sizes in the interval $[0, t]$ are precisely the lengths of excursions, of the underlying Brownian motion, that end before time τ_t ([28], Section XII.2).

Let $\tilde{\mathcal{J}}_1 \geq \tilde{\mathcal{J}}_2 \geq \dots$ (resp. $\mathcal{J}_1 \geq \mathcal{J}_2 \geq \dots$ and $\hat{\mathcal{J}}_1 \geq \hat{\mathcal{J}}_2 \geq \dots$) be the ranked jump-sizes of $\tilde{\tau}$ over the interval $[0, 1]$ (resp. the ranked jump-sizes of τ over the interval $[0, a]$ and the ranked excursion lengths of X_a over the interval $[0, 1]$). As we have $\tilde{\tau}_1 = \tau_a/a^2$ and $\tilde{\mathcal{J}}_k = \mathcal{J}_k/a^2$,

$$\begin{aligned} \left(\frac{\tilde{\mathcal{J}}_1}{\tilde{\tau}_1}, \frac{\tilde{\mathcal{J}}_2}{\tilde{\tau}_1}, \dots \mid \tilde{\tau}_1 = \frac{1}{a^2} \right) &\stackrel{\text{law}}{=} \left(\frac{\mathcal{J}_1}{\tau_a}, \frac{\mathcal{J}_2}{\tau_a}, \dots \mid \tau_a = 1 \right) \\ &\stackrel{\text{law}}{=} (\mathcal{J}_1, \mathcal{J}_2, \dots \mid \tau_a = 1) \\ &\stackrel{\text{law}}{=} (\hat{\mathcal{J}}_1, \hat{\mathcal{J}}_2, \dots), \end{aligned}$$

the last identity due to the fact that, as remarked in Section 1, X_a has the same distribution as the reflected Brownian motion conditioned on $\tau_a = 1$ [27, formula (5.a)]. In view of these identities, [7, Corollary 5] asserts that the size-biased random permutation of $(\hat{\mathcal{J}}_1, \hat{\mathcal{J}}_2, \dots)$ has the same distribution, given by (6.8), as \mathcal{J}^* .

Incidentally, Theorem 1.5 of [13] shows that the sequences of excursion lengths of X_a and Z_a have the same distribution, suggesting partly Theorems 2.5 and 2.6 of this paper. The fact that the sequence of lengths of excursions has the same distribution for Z_a as for X_a was noticed simultaneously in [8, 13],

and leads to conjecture an interesting alternative (through the fragmentation process of excursions of $\Psi_a e$) for the original construction, given by Aldous and Pitman in [6], of the additive coalescent (see [8], 2nd version, for the proof). In [13], it is shown that the process, with time parameter a , of block lengths of a random element $\omega \in P_{n,n-\lfloor a\sqrt{n} \rfloor}$, converges to the same fragmentation process. This parallels the behavior observed in [3] for the sizes of connected components of the random graph during the phase transition.

Order of excursions. Let us adopt the notation of [34], Lecture 4, for the Brownian scaling of a function f over the interval $[a, b]$:

$$f^{[a,b]} = \left(\frac{1}{\sqrt{b-a}} f(a + t(b-a)), \quad 0 \leq t \leq 1 \right).$$

According to the theory of excursions (see [27, Section 6] for details and references), we can build a copy X of X_a by applying the infinite analog of a random shuffle to the excursions of X_a .

More formally, let $(e_k)_{k \geq 1}$ be a sequence of independent random variables distributed as the normalized Brownian excursion e , and let $(U_k)_{k \geq 1}$ be a sequence of independent random variables, uniform on $[0, 1]$. Moreover J^* , $(e_k)_{k \geq 1}$ and $(U_k)_{k \geq 1}$ are assumed to be independent. Set

$$(6.9) \quad G(k) = \sum_{i: U_i < U_k} J_i^*,$$

$$(6.10) \quad D(k) = \sum_{i: U_i \leq U_k} J_i^*.$$

With probability 1, $U_i = U_j \implies i = j$ and the terms of J^* add up to 1, so the stochastic process X that is zero outside $\bigcup_{k \geq 1} [G(k), D(k)]$, and satisfies

$$X^{[G(k), D(k)]} = e_k,$$

for $k \geq 1$, is well defined and continuous, and has the same distribution as X_a [27]. Note that a.s.

$$L_{G(k)}(X) = L_{D(k)}(X) = aU_k,$$

with the notations of Theorem 2.6. The definitions of $G(k)$ and $D(k)$ reflect the fact that the excursions of X are ranked from left to right in increasing order of their number U_k , generating thus a random shuffle of the excursions, independently of their shapes e_k and their lengths J_k^* .

Order of blocks. Let us give a different formulation, more convenient for our purposes, of the well known fact that a random shuffle of the blocks of a random confined parking scheme still produces a random confined parking scheme: we only keep track of this shuffle on the profile of the parking scheme.

Let $H_k = (h_j^{(k)})_{j \geq 1}$ be independent sequences of possibly dependent random variables $h_j^{(k)}$, distributed according to $\tilde{\mu}_{j,1}$. Assuming y is drawn at random

in $CP_{n,n-\ell}$, independently of the sequences H_k , let us add 1 to each of the ℓ first coordinates of $R(y)$: this operation produces a new sequence of random variables $j_n = (j_n(k))_{k \geq 1}$, whose terms add up to n ; these can be regarded as lengths of blocks including a final empty place (allowing empty blocks consisting only of one empty place). Note that $j_n(k) > 0$ if and only if $k \leq \ell$, and that $J_n(k) = j_n(k)/n$ still satisfies

$$J_n \xrightarrow{\text{weakly}} J^*.$$

Let, in analogy with (6.9) and (6.10),

$$(6.11) \quad G(k, n) = \sum_{i: U_i < U_k} J_n(i),$$

$$(6.12) \quad D(k, n) = \sum_{i: U_i \leq U_k} J_n(i),$$

and let g_n be defined by

$$g_n^{[G(k,n), D(k,n)]} = h_{j_n(k)}^{(k)}, \quad k \leq \ell.$$

The $h_{j_n(k)}^{(k)}$ are thus sorted by increasing order of the attached U_k . It is easily seen that a random shuffle of the blocks (including a trailing empty place) in a random confined parking scheme produces a new random confined parking scheme with the same distribution, and that the structure of each block of length j is distributed according to $CP_{j,j-1}$. Hence, checking that our scalings match properly, g_n is distributed according to $\tilde{\mu}_{n,\ell}$.

PROOF OF THEOREM 4.2. From [14] (or as a very special case of Theorem 4.3, since $CP_{n,n-1} = E_{n,n-1}$), we know that

$$\tilde{\mu}_{n,1} \xrightarrow{\text{weakly}} e,$$

so the Skorohod representation theorem provides the existence, on some probability space $\tilde{\Omega}$, of a Brownian excursion e and of a sequence $H = (h_j)_{j \geq 1}$ of possibly dependent random variables h_j , distributed according to $\tilde{\mu}_{j,1}$, such that, almost surely, h_j converges uniformly to e . The same theorem provides the existence, on some probability space $\hat{\Omega}$, of random variables J_n and J^* , distributed as above, and such that, almost surely, for any $k \geq 1$,

$$(6.13) \quad \lim_n J_n(k) = J_k^*.$$

Finally, by a denumerable product of copies of $[0, 1]$, $\tilde{\Omega}$ and $\hat{\Omega}$, we build on some space Ω , simultaneously, random variables $e_k, H_k = (h_j^{(k)})_{j \geq 1}, U_k, J_n$ and J^* , where $k, n = 1, 2, \dots$, with the distributions given above, such that for each $k \geq 1$ (6.13) holds and

$$(6.14) \quad h_j^{(k)} \xrightarrow{\text{uniformly}} e_k \quad \text{as } j \rightarrow \infty;$$

moreover, the variables $(e_k, H_k), U_k$, and $((J_n)_{n \geq 1}, J^*)$ are all independent of each other.

Define X and g_n as above, and define further, for $N \geq 1$, X_N and $g_{n,N}$ in the same way, but using only excursions (blocks) with index $k \leq N$. Thus, for example, $X_N = X$ on $\cup_1^N [G(k), D(k)]$, while $X_N = 0$ outside this set. Since the excursion lengths $D(k) - G(k) \rightarrow 0$, and X is (uniformly) continuous on $[0, 1]$, $X_N \rightarrow X$ in $C[0, 1]$ (i.e., uniformly) as $N \rightarrow \infty$.

Note that as both J_n and J^* have nonnegative terms that add up to 1, (6.13) yields ℓ^1 -convergence of J_n to J^* ; and thus by (6.9), (6.10), (6.11), (6.12), $G(n, k) \rightarrow G(k)$ and $D(n, k) \rightarrow D(k)$ for every k , which together with (6.14) and $j_n(k) = nJ_n(k) \rightarrow \infty$ easily implies that, for fixed N , $g_{n,N} \rightarrow X_N$ a.s. in $C[0, 1]$ as $n \rightarrow \infty$. \square

Informally, we now let $N \rightarrow \infty$. In order to justify this, we need the following estimate, which will be proved below.

PROPOSITION 6.3. *For every $\varepsilon > 0$,*

$$\lim_{N \rightarrow \infty} \limsup_{n \rightarrow \infty} \Pr(\|g_{n,N} - g_n\| > \varepsilon) = 0,$$

where $\|f\| = \sup_t |f(t)|$ denotes the norm in $C[0, 1]$.

Now, let $\varepsilon > 0$. Then

$$\begin{aligned} \Pr(\|g_n - X\| > 3\varepsilon) &\leq \Pr(\|g_n - g_{n,N}\| > \varepsilon) \\ &\quad + \Pr(\|g_{n,N} - X_N\| > \varepsilon) + \Pr(\|X_N - X\| > \varepsilon) \end{aligned}$$

where, by Proposition 6.3 and the comments above, all three terms on the right hand side can be made arbitrarily small by first choosing N and then n large enough. Consequently, $g_n \rightarrow X$ (uniformly) in probability, which completes the proof of Theorem 4.2. (See also [12], Theorem 4.2, where the same type of argument is stated for convergence in distribution.)

PROOF OF PROPOSITION 6.3. The Dvoretzky-Kiefer-Wolfowitz inequality implies

$$\sup_j E \|h_j\|^2 < \infty$$

(see [14], Lemma 3.3 and Proposition 4.1). Denote this supremum by A . Then, given J_n , by Chebyshev's inequality,

$$\begin{aligned} \Pr(\|g_{n,N} - g_n\| > \varepsilon) &= \Pr\left(\max_{k > N} \sqrt{J_n(k)} \|h_{j_n(k)}^{(k)}\| > \varepsilon\right) \\ &\leq \sum_{k > N} \Pr\left(\sqrt{J_n(k)} \|h_{j_n(k)}^{(k)}\| > \varepsilon\right) \\ &\leq \sum_{k > N} \varepsilon^{-2} A J_n(k), \end{aligned}$$

and thus, unconditionally,

$$\Pr(\|g_{n,N} - g_n\| > \varepsilon) \leq E \left(\min \left(1, A\varepsilon^{-2} \sum_{k>N} J_n(k) \right) \right).$$

Hence, by dominated convergence,

$$\begin{aligned} \limsup_{n \rightarrow \infty} \Pr(\|g_{n,N} - g_n\| > \varepsilon) &\leq \lim_{n \rightarrow \infty} E(\min(1, A\varepsilon^{-2} \sum_{k>N} J_n(k))) \\ &= E \left(\min \left(1, A\varepsilon^{-2} \sum_{k>N} J_k^* \right) \right), \end{aligned}$$

which tends to 0 as $N \rightarrow \infty$ by dominated convergence again. \square

7. Proof of Theorem 2.2. Due to the Skorohod representation theorem, and to Theorem 4.2, there exist on some probability space, a sequence f_n of random variables distributed according to $\tilde{\mu}_{n, \lfloor a\sqrt{n} \rfloor + 1}$, and a continuous copy X of X_a such that, almost surely, $f_n(t)$ converges, uniformly for $t \in [0, 1]$, to $X(t)$. Possibly at the price of enlarging the probability space, consider a random variable U , uniform on $[0, 1]$ and independent of $(f_n)_{n \geq 1}$ and X .

On the one hand, almost surely,

$$f_n \left(t + \frac{\lfloor nU \rfloor}{n} \right) \xrightarrow{\text{uniformly}} X(t + U).$$

On the other hand, according to Proposition 4.4, $f_n \left(\cdot + \frac{\lfloor nU \rfloor}{n} \right)$ is distributed according to $\mu_{n, \lfloor a\sqrt{n} \rfloor + 1}$. Thus, owing to Theorem 4.1,

$$X(\cdot + U) \stackrel{\text{law}}{=} Y_a. \quad \square$$

8. Proof of Theorem 2.8. Theorem 2.8 follows from (1.1)–(1.4) and the following formulas for the local times of Y_a and Z_a .

PROPOSITION 8.1. *With $Y_a = \Psi_a b$, for any t ,*

$$(8.1) \quad L_t(Y_a) = \sup_{-\infty \leq s \leq t} \{as - b(s)\} - \sup_{-\infty \leq s \leq 0} \{as - b(s)\}.$$

With $Z_a = \Psi_a e$, for any t ,

$$(8.2) \quad L_t(Z_a) = \sup_{-\infty \leq s \leq t} \{as - e(s)\}$$

and for $t \in [0, 1]$,

$$(8.3) \quad L_t(Z_a) = \sup_{0 \leq s \leq t} \{as - e(s)\}.$$

PROOF. By a well known theorem of Paul Lévy ([28], Theorem VI.2.3) a.s., on $[0, +\infty)$,

$$L_t \left(B_t - \inf_{0 \leq s \leq t} B_s \right) = - \inf_{0 \leq s \leq t} B_s,$$

or, with the notation $\Phi_0(X)_t = - \inf_{0 \leq s \leq t} X_s$,

$$L_t(B + \Phi_0(B)) = \Phi_0(B)_t.$$

On any interval $[0, 1 - \delta]$, the Brownian bridge b has an absolutely continuous distribution w.r.t. the distribution of B , and so has $b(t) - at$. Consequently, for $0 \leq t < 1$, writing $b^{(a)} = b(t) - at$,

$$(8.4) \quad L_t(b^{(a)} + \Phi_0(b^{(a)})) = \Phi_0(b^{(a)})_t.$$

This extends by continuity to $t = 1$. Now, define

$$\Phi(X)_t = - \inf_{-\infty \leq s \leq t} X_s,$$

and observe that

$$\Phi_0(b^{(a)})_t \leq \Phi(b^{(a)})_t$$

with equality if and only if t is larger or equal than the first nonnegative zero t_0 of the process $Y_a = b^{(a)} + \Phi(b^{(a)})$. On $[t_0, 1]$, we have thus

$$Y_a(t) = b^{(a)}(t) + \Phi_0(b^{(a)})_t.$$

As a consequence, on $[t_0, 1]$, (8.4) yields

$$(8.5) \quad \begin{aligned} L_t(Y_a) &= L_t(Y_a) - L_{t_0}(Y_a) \\ &= \Phi_0(b^{(a)})_t - \Phi_0(b^{(a)})_{t_0} \\ &= \Phi(b^{(a)})_t - \Phi(b^{(a)})_{t_0} \\ &= \Phi(b^{(a)})_t - \Phi(b^{(a)})_0. \end{aligned}$$

This proves (8.1) for $t \in [t_0, 1]$. The formula extends easily to $[0, 1]$, since both sides vanish on $[0, t_0]$, and due to the periodicity of Y_a and b , to the whole line.

For the assertions on Z_a , let $b(t) = e(t + U) - e(U)$, where as usual U is uniform on $[0, 1]$ and independent of e . Then, $Z_a(t) = Y_a(t - U)$ and thus, using (8.1) or (8.5) and $\Phi(b^{(a)}) = Y_a - b^{(a)}$,

$$\begin{aligned} L_t(Z_a) &= L_{t-U}(Y_a) - L_{-U}(Y_a) \\ &= \Phi(b^{(a)})_{t-U} - \Phi(b^{(a)})_{-U} \\ &= Y_a(t - U) - b(t - U) + a(t - U) - Y_a(-U) + b(-U) - aU \\ &= Z_a(t) - e(t) + at, \end{aligned}$$

which yields (8.2) and (8.3). \square

9. Proof of Theorem 4.6(i, iii). We assume that a random parking scheme $\omega^{(m)}$ in $P_{n,m}$ is constructed as in Section 6.1, so that the processes α_m defined there converge a.s. uniformly to a Brownian bridge $b(t)$. Then, by Proposition 6.1, $h_n(\cdot, \omega^{(m)})$ converges a.s. uniformly to $Y_a = \Psi_a b$.

Moreover, by Proposition 5.5 and (6.5),

$$\frac{V_{0, [nt]}}{\sqrt{n}} = \frac{\Delta_{[nt]} - \Delta_0}{\sqrt{n}} \rightarrow \sup_{s \leq t} (as - b(s)) - \sup_{s \leq 0} (as - b(s)),$$

uniformly on $[0, 1]$, and thus $v_n(t, \omega^{(m)})$ has the same uniform limit. By Proposition 8.1, the right hand side equals the local time $L_t(Y_a)$, and we have proved the following complement to Proposition 6.1:

PROPOSITION 9.1. *With the assumptions above, there is almost surely uniform convergence of $v_n(\cdot, \omega^{(m)})$ to $L(Y_a)$ on $[0, 1]$.*

Propositions 6.1 and 9.1 together yield Theorem 4.6(i).

For part (iii), we use the additional assumptions of Section 6.2, and obtain then easily from Proposition 9.1, using $v_n(t, p(\omega^{(m)})) = v_n(t + J/n, \omega^{(m)}) - v_n(J/n, \omega^{(m)})$, the following analogue for Z_a :

PROPOSITION 9.2. *With the assumptions above, there is almost surely uniform convergence of $v_n(\cdot, p(\omega^{(m)}))$ to $L(Z_a)$ on $[0, 1]$.*

10. Proofs of Theorem 2.5 and 4.6(ii). In view of Theorem 4.2, the proof of Theorem 2.5 reduces to the proof of

THEOREM 10.1. *If $a > 0$, and τ and $\tilde{\tau}$ are defined as in Theorem 2.5, then*

$$\begin{aligned} \tilde{\mu}_{n, [a\sqrt{n}]} &\xrightarrow{\text{weakly}} Z_a(\tau + \cdot) \\ &\stackrel{\text{law}}{=} Y_a(\tilde{\tau} + \cdot). \end{aligned}$$

PROOF. Set $m = n - [a\sqrt{n}]$ and define M_n and $\tilde{M}_n \in [0, 1]$ by

$$\begin{aligned} R^{[(n-m)U]} p(\omega) &= r^{nM_n} p(\omega), \\ R^{[(n-m)U]} \omega &= r^{n\tilde{M}_n} \omega. \end{aligned}$$

By the definitions of R and r on $P_{n,m}$, we have

$$(10.1) \quad v_n(\tilde{M}_n, \omega) = v_n(M_n, p(\omega)) = \frac{[(n-m)U]}{\sqrt{n}}.$$

Due to Proposition 8.1, $s \rightarrow \ell(s) = L_s(Z_a)$, $s \in [0, 1]$, is continuous and nondecreasing from 0 to a , with the consequences that the set $A = \{x \in [0, a] : \#\ell^{-1}(x) > 1\}$ is denumerable, and that, furthermore, for $x \notin A$, ℓ^{-1}

is uniquely defined and continuous: if $y_n \in [0, 1]$ with $\ell(y_n) \rightarrow x \notin A$, then $y_n \rightarrow \ell^{-1}(x)$. Assume again that $\omega = \omega^{(m)}$ is as in Subsections 6.1 and 6.2. Due to (10.1),

$$|\ell(M_n) - aU| \leq \frac{2}{\sqrt{n}} + \|v_n(\cdot, p(\omega)) - \ell\|_\infty,$$

which a.s. converges to zero as $n \rightarrow \infty$ by Proposition 9.2, and thus, if $aU \notin A$, that is, almost surely,

$$\lim_{n \rightarrow \infty} M_n = \ell^{-1}(aU) = \tau.$$

For the same reasons,

$$\lim \tilde{M}_n = \tilde{\tau} \quad \text{a.s.}$$

As a consequence, using Propositions 6.1 and 6.2 again, almost surely, $h_n(R^{[(n-m)U]} \omega, \cdot)$ [resp. $h_n(R^{[(n-m)U]} p(\omega), \cdot)$] converges uniformly to $Y_a(\tilde{\tau} + \cdot)$ [resp. $Z_a(\tilde{\tau} + \cdot)$]. On the other hand, according to Proposition 4.5, $R^{[(n-m)U]} \omega$ and $R^{[(n-m)U]} p(\omega)$ are random uniform on $CP_{n,m}$, with the consequence that both $h_n(R^{[(n-m)U]} \omega, \cdot)$ and $h_n(R^{[(n-m)U]} p(\omega), \cdot)$ are distributed according to $\tilde{\mu}_{n, \lfloor a\sqrt{n} \rfloor}$. \square

Similarly, for Theorem 4.6(ii), we consider a copy $X = Y_a(\tilde{\tau} + \cdot)$ of X_a , and we note that, due to Proposition 9.1, $v_n(R^{[(n-m)U]} \omega, t)$ converges uniformly to $L_{\tilde{\tau}+t}(Y_a) - L_{\tilde{\tau}}(Y_a) = L_t(X)$.

11. Proof of Theorem 2.6. If $0 < t < 1$, Proposition 8.1 yields

$$L_t(Z_a) = \sup_{0 \leq s \leq t} \{as - e(s)\} < at,$$

since $s \mapsto as - e(s)$ is a continuous function and $as - e(s) < at$ for every $s \in [0, t]$. As a consequence, $t \mapsto \chi(t) = L_t(Z_a) - at$, which has period 1, reaches its maximum 0 exactly at the integers.

By Theorem 2.1, we can assume that $Y_a = Z_a(U + \cdot)$, and then

$$\begin{aligned} L_t(Y_a) - at &= L_{U+t}(Z_a) - L_U(Z_a) - at \\ &= \chi(U + t) - \chi(U). \end{aligned}$$

Hence $L_t(Y_a) - at$ reaches its maximum exactly at $\{n - U : n \in \mathbb{Z}\}$, so $\tilde{V} = 1 - U$ and $Y_a(\tilde{V} + t) = Z_a(t)$, which proves (ii).

The proof for X_a is done the same way, using either Theorem 2.5, or the result just proved for Y_a and Theorem 2.2. \square

12. Concluding remarks. Concerning the problem of possible other shifts, note that there exists only one shift from X_a or Y_a to Z_a . Actually there is no nontrivial shift from Z_a to itself, while Y_a is stationary, that is, invariant under any nonrandom shift, and X_a is invariant under shifts $T_x(X_a)$ for any x . This last point follows from Theorem 2.5, but it can also be seen more directly on the definition of X_a based on the sequences (e, J, U) of shapes, lengths and sorting numbers of its excursions: if we replace the sorting numbers $U = (U_i)_{i \geq 1}$ by $U^{(x)} = \{U_i - x\}_{i \geq 1}$, it produces a new process which is just $X_a(T_x(X_a) + \cdot)$. But

$$U \stackrel{\text{law}}{=} U^{(x)}.$$

This paper deals with more or less the same stochastic processes as [6, 7, 25]. Maybe less apparent, but somewhat expected, they deal with combinatorial notions that are tightly related: the one-to-one correspondence between labeled trees and elements of $CP_{n,n-1}$ (see [14] and the references therein) extends easily to a one-to-one correspondence between random forests à la Pavlov [20, 22] with $n - m$ roots and m non-root vertices, on one hand, and elements of $CP_{n,m}$, on the other hand (see Figure 4). But random forests à la Pavlov can be seen as the set of genealogical trees of a Galton-Watson branching process started with $n - m$ individuals, with Poisson offspring, conditioned to have total progeny equal to n [20]. As such, they are also considered in [6], Lemma 18, and [25], Section 3. The correspondence between Pavlov’s forests and confined parking schemes is described carefully in [13], Sections 5.1 and 8, where it is used to explain the relation between two different constructions of the standard additive coalescent [7, 8], so we only sketch it here: each tree of the Pavlov’s forest is in correspondence with a parking block of the parking scheme, seen as an element of $CP_{n,n-1}$ (see Figure 4), and the first try of car c_m is on the k^{th} place in a given parking block if the vertex labeled m is a de-

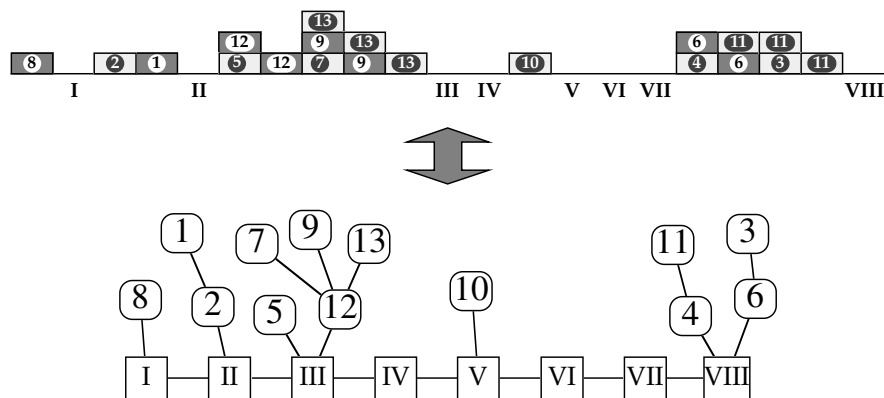

FIG. 4. Correspondence $CP_{13,21} \leftrightarrow$ Pavlov’s forests.

scendant of the k th node visited in a breadth-first search of the corresponding tree of the forest.

Finally we remark that the shifts studied in this paper, together with the construction in Section 6, imply the following improved version of Theorem 1.10 in [13].

Let ρ be a random variable uniformly distributed on $[0, 1]$ and independent of a process X that stands indifferently for X_a , Y_a or Z_a . Let g (resp. d) denote the last zero of X before ρ (resp., the first zero of X after ρ), and let $R = d - g$. Set, using Brownian scaling as in Section 6, $q = X^{[g,d]}$ and $r = X^{[d,g+1]}$.

THEOREM 12.1. *We have:*

- (i) R has the same distribution as $\frac{N^2}{a^2+N^2}$, in which N is standard Gaussian.
- (ii) q is a normalized Brownian excursion, independent of (g, d) .
- (iii) Given (R, q) , r is distributed as $X_{a/\sqrt{1-R}}$.

Acknowledgments. Thanks to Philippe Flajolet for putting the two authors in contact with each other, and to Don Knuth for making this possible by first putting the second author in contact with Philippe Flajolet. A starting point of this paper were discussions with Marc Yor, and especially one about the possible relation between parking and process X_a . Thanks also to him for pointing to us many interesting papers, such as [8, 25, 27]. Thanks to Jean Bertoin for giving an early access to the second version of [8] and to [9].

REFERENCES

- [1] ALDOUS, D. (1988). Hashing with linear probing, under non-uniform probabilities. *Probab. Engng. Inform. Sci.* **2** 1–14.
- [2] ALDOUS, D. J. (1991). The continuum random tree. II: An overview. In *Stochastic Analysis (Durham 1990)*, *Lond. Math. Soc. Lect. Note Ser.* **167**, 23–70. Cambridge Univ. Press, Cambridge.
- [3] ALDOUS, D. J. (1997). Brownian excursions, critical random graphs and the multiplicative coalescent. *Ann. Probab.* **25** 812–854.
- [4] ALDOUS, D. J. (1998). Brownian excursion conditioned on its local time. *Electron. Comm. Probab.* **3** 79–90.
- [5] ALDOUS, D. J. (1999). Deterministic and stochastic models for coalescence (aggregation and coagulation): a review of the mean-field theory for probabilists. *Bernoulli* **5** 3–48.
- [6] ALDOUS, D. J. and PITMAN, J. (1994). Brownian bridge asymptotics for random mappings. *Random Structures Algorithms* **5** 487–512.
- [7] ALDOUS, D. J. and PITMAN, J. (1998). The standard additive coalescent. *Ann. Probab.* **26** 1703–1726.
- [8] BERTOIN, J. (2000). A fragmentation process connected with Brownian motion. *Probab. Theory Related Fields* **117** 289–301.
- [9] BERTOIN, J. (2000). Clustering statistics for sticky particles with Brownian initial velocity. *J. Math. Pures Appl.* **79** **2** 173–194.
- [10] BERTOIN, J. and PITMAN, J. (1994). Path transformations connecting Brownian bridge, excursion and meander. *Bull. Sci. Math.* **118** **2** 147–166.
- [11] BIANE, Ph. (1986). Relations entre pont et excursion du mouvement brownien réel. *Ann. Inst. H. Poincaré Probab. Statist.* **22** **1** 1–7.

- [12] BILLINGSLEY, P. (1968). *Convergence of Probability Measures*. Wiley, New York.
- [13] CHASSAING, P and LOUCHARD, G. (1999). Phase transition for parking blocks, Brownian excursion and coalescence. Available at www.iecn.u-nancy.fr/~chassain.
- [14] CHASSAING, P. and MARCKERT, J. F. (2001). Parking functions, empirical processes and the width of rooted labeled trees. *Electronic J. Combinatorics* **8**(1), R14.
- [15] DURRETT, R. and IGLEHART, D. L. (1977). Functionals of Brownian meander and Brownian excursion. *Ann. Probab.* **5** 130–135.
- [16] EVANS, S. N. and PITMAN, J. (1998). Construction of Markovian coalescents. *Ann. Inst. H. Poincaré Probab. Statist.* **34** 339–383.
- [17] FLAJOLET, P., POBLETE, P. and VIOLA, A. (1998). On the analysis of linear probing hashing. *Algoritmica* **22** 490–515.
- [18] KNUTH, D. E. (1998). *The Art of Computer Programming 3. Sorting and Searching*, 2nd ed. Addison-Wesley, Reading, MA.
- [19] KNUTH, D. E. (1998). Linear probing and graphs. *Algoritmica* **22** 561–568.
- [20] KOLCHIN, V. F. (1986). *Random Mappings*. Nauka, Moscow. [In Russian. English translation (1986). Optimization Software, New York.]
- [21] KONHEIM, A. G. and WEISS, B. (1966). An occupancy discipline and applications. *SIAM J. Appl. Math.* **14** 1266–1274.
- [22] PAVLOV, Yu. L. (1977). The asymptotic distribution of maximum tree size in a random forest. *Theory Probab. Appl.* **22** 509–520.
- [23] PAVLOV, Yu. L. (1996). *Random Forests*. Karelian Centre Russian Acad. Science, Petrozavodsk. (In Russian.)
- [24] PERMAN, M., PITMAN, J. and YOR, M. (1992). Size-biased sampling of Poisson point processes and excursions. *Probab. Theory Related Fields* **92** 21–39.
- [25] PITMAN, J. (1999). The SDE solved by local times of a Brownian excursion or bridge derived from the height profile of a random tree or forest. *Ann. Probab.* **27** 261–283.
- [26] PITMAN, J. and STANLEY, R. (1999). A polytope related to empirical distributions, plane trees, parking functions, and the associahedron. Technical Report 560, Dept. Statistics, Univ. California, Berkeley. Available at stat-www.berkeley.edu/users/pitman/bibliog.html.
- [27] PITMAN, J. and YOR, M. (1992). Arcsine laws and interval partitions derived from a stable subordinator. *Proc. London Math. Soc. Ser. (3)* **65** 326–356.
- [28] REVUZ, D. and YOR, M. (1999). *Continuous Martingales and Brownian Motion*, 3rd ed. Springer, New York.
- [29] ROGERS, L. C. G. and WILLIAMS, D. (1994). *Diffusions, Markov Processes, and Martingales 1. Foundations*. 2nd ed. Wiley, Chichester.
- [30] SPENCER, J. (1997). Enumerating graphs and Brownian motion. *Comm. Pure Appl. Math.* **50** 291–294.
- [31] STANLEY, R. (1997). Parking functions and noncrossing partitions. *Electron. J. Combinatorics* **4**.
- [32] STANLEY, R. (1998). Hyperplane arrangements, parking functions, and tree inversions. In *Mathematical Essays in Honor of Gian-Carlo Rota* (B. Sagan and R. Stanley, eds.) 259–375. Birkhäuser, Boston.
- [33] VERVAAT, W. (1979). A relation between Brownian bridge and Brownian excursion. *Ann. Probab.* **7** 143–149.
- [34] YOR, M. (1995). Local times and excursions for Brownian motion: a concise introduction. *Lecciones en Matemáticas*, Univ. Central de Venezuela.

INSTITUT ELIE CARTAN
 BP 239
 54 506 VANDOEUVRE CEDEX
 FRANCE
 E-MAIL: chassain@iecn.u-nancy.fr

DEPARTMENT OF MATHEMATICS
 UPPSALA UNIVERSITY
 P.O. BOX 480
 751 06 UPPSALA
 SWEDEN
 E-MAIL: svante@math.uu.se